



# V 12: Miniature photoelectric switches in M 12 housings

	<b>Photoelectric proximity switches</b>
	<b>Photoelectric reflex switches</b>
	<b>Through-beam photoelectric switches</b>



**T**

The V 12 series of photoelectric switches in the miniature round M 12 housing offers large scanning ranges. Simple installation is a characteristic feature of this sensor type. M 12 thread with lock nut simplify handling. V 12 sensors are the ideal option for standard applications where space is restricted.

In addition, V 12 photoelectric switches are often the perfect complement to inductive or capacitive sensors in M 12 housings.

They are suitable for applications in:

- the packaging and printing industries,
- assembly and handling systems,
- conveyor systems, and
- the construction of special-purpose machines.

The V 12 optical systems and their scanning ranges:

- VS/VE 12 through-beam photoelectric switch: 4m,
- VL 12 photoelectric reflex switch: 2 m (PL 80 A),
- VT 12 photoelectric proximity switch, energetic, for standard scanning tasks:
  - Scanning distance 100 mm (90 % remission),
  - Scanning distance 200 mm (90 % remission).

Other features of the system include:

$V_S = 10 \dots 30$  V DC, switching output PNP, M 12 plug or cable, IP 67 and metal housing.

► Detecting objects on conveyor belts using VS/VE 12 through-beam photoelectric switches.

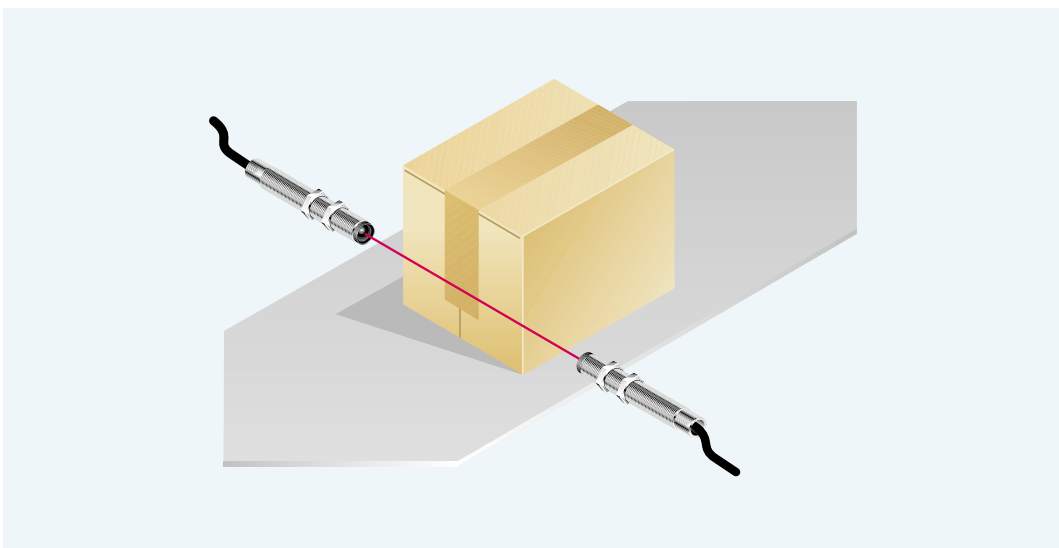

▼ VL 12 photoelectric reflex switches can also be used for the reliable detection of reflective surfaces, for example film-wrapped cardboard boxes.

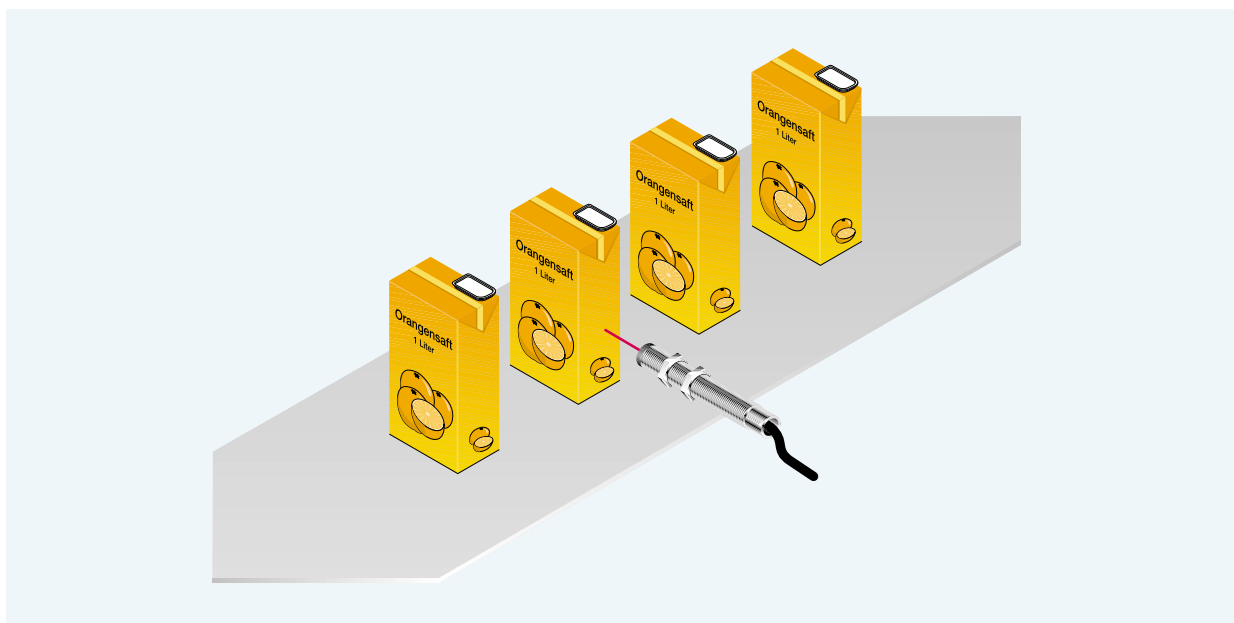
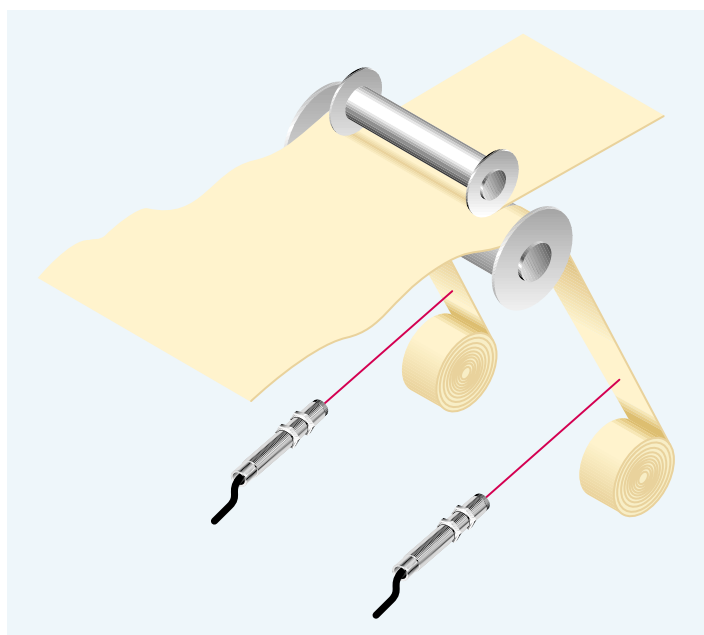
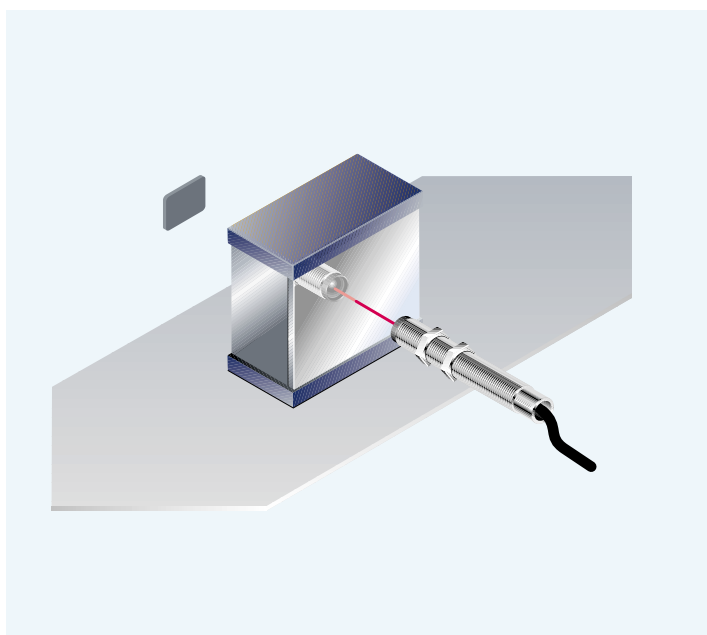

▲ VT 12 photoelectric proximity switches used to ensure that waste is rolled up correctly when paper and film strips are cut.

◀ Is an object present or not? The VT 12 photoelectric proximity switch provides the answer.

	<b>Scanning distance</b> 2...110 mm
	<b>Scanning distance</b> 2...210 mm
<b>Photoelectric proximity switches</b>	

- Robust metal housing
- Light-switching
- Cable or plug connection
- Reverse polarity and short circuit protection

**Dimensional drawing**

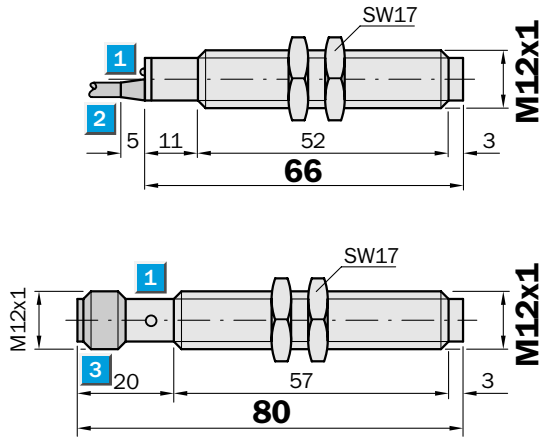

- 1 LED signal strength indicator, LED red
- 2 Connecting cable
- 3 4-pin, M 12 plug

**Connection types**

VT 12-1 P1112	VT 12-1 P1410
VT 12-1 P1132	VT 12-1 P1430

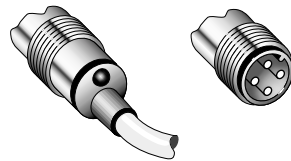

<b>Accessories</b>	page
Cable receptacles	496
Mounting brackets	510

3 x 0.14 mm <sup>2</sup>	4-pin, M12
--------------------------	------------

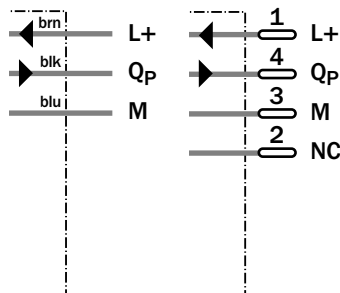

Technical Data		VT 12-	1P1112	1P1410	1P1132	1P1430						
<b>Scanning distance</b> , max. typical	2...110 mm <sup>1)</sup>											
<b>Operating distance</b>	5...100 mm <sup>1)</sup>											
Light source <sup>2)</sup> , light type	LED, infrared light											
Light spot diameter	Approx. 5 mm at 100 mm											
Angle of dispersion, sender	Approx. 2,8°											
<b>Scanning distance</b> , max. typical	2...210 mm <sup>3)</sup>											
<b>Operating distance</b>	5...200 mm <sup>3)</sup>											
Light source <sup>2)</sup> , light type	LED, infrared light											
Light spot diameter	Approx. 10 mm at 200 mm											
Angle of dispersion of sender	Approx. 2.8°											
<b>Supply voltage V<sub>S</sub></b>	10...30 V DC <sup>4)</sup>											
Ripple <sup>5)</sup>	± 10 %											
Current consumption <sup>6)</sup>	≤ 20 mA											
<b>Switching outputs</b>	PNP, open collector: Q											
Output current I <sub>A</sub> max.	200 mA											
Light receiver, switching mode	Light-switching											
Response time <sup>7)</sup>	≤ 5.0 ms											
Max. switching frequency <sup>8)</sup>	100/s											
<b>Connection types</b> cable	PVC, 2 m <sup>9)</sup> ; 3 x 0.14 mm <sup>2</sup> , ø 3.1 mm											
plug	4-pin, M 12											
<b>VDE protection class</b> <sup>10)</sup>	□											
Circuit protection <sup>11)</sup>	A, B, C, D											
<b>Enclosure rating</b>	IP 67											
<b>Ambient temperature T<sub>A</sub></b>	- 25 °C... + 70 °C											
<b>Weight</b>	Approx. 70 g inc. cable Approx. 35 g inc. plug											
<b>Housing material</b>	Nickel-coated brass housing/ PA; Optics: PC											

- 1) Object to be detected with 90 % remission (relating to standard white in acc. with DIN 5033)
- 2) Average service life 100,000 h at T<sub>A</sub> = + 25 °C
- 3) Object to be detected with 90 % remission 100 x 100 mm
- 4) Limit values
- 5) May not exceed or fall short of V<sub>S</sub> tolerances
- 6) Without load
- 7) Signal transit time with resistive load
- 8) With light/dark ratio 1:1
- 9) Do not bend below 0 °C
- 10) Reference voltage DC 50 V
- 11) A = V<sub>S</sub> connections reverse-polarity protected  
B = Inputs and outputs reverse-polarity protected  
C = Interference pulse suppression  
D = Outputs overload and short-circuit protected

**Scanning distance**

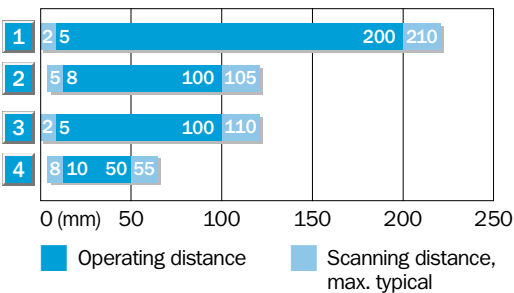

- 1) "Larger" scanning range on white, 90 % remission
- 2) "Larger" scanning range on black, 6 % remission
- 3) "Smaller" scanning range on white, 90 % remission
- 4) "Smaller" scanning range on black, 6 % remission

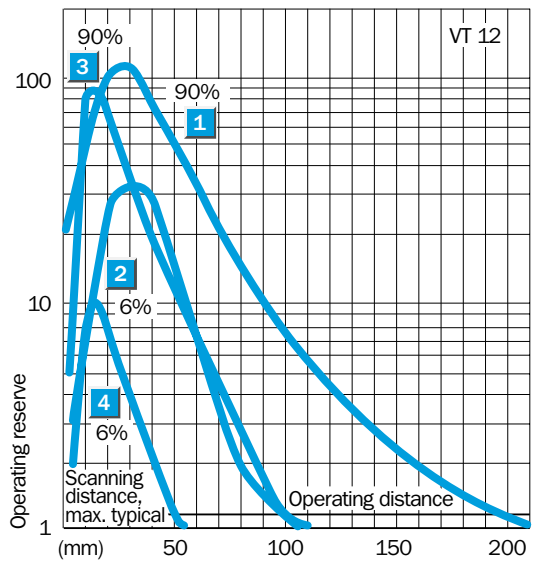

**Order information**

Type	Part no.
VT12-1 P 1112	6 011 132
VT12-1 P 1410	6 011 133
VT12-1 P 1132	6 011 143
VT12-1 P 1430	6 011 134

**Scanning range**  
**0.005...2.5 m**

Photoelectric reflex switches

- Flat optics for flush fitting
- Robust metal housing
- Dark-switching
- Cable or plug connection
- Reverse polarity and short circuit protection

Dimensional drawing

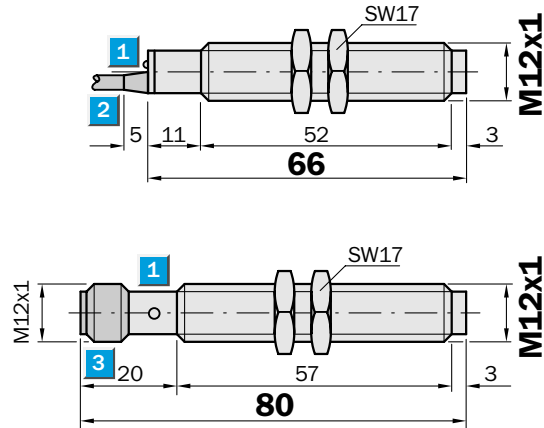

- 1 LED signal strength indicator, LED red
- 2 Connecting cable
- 3 4-pin, M 12 plug



Connection types

VL 12-1 P2132    VL 12-1 P2430

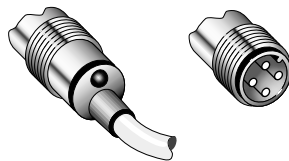

Accessories	page
Cable receptacles	496
Mounting brackets	510
Reflectors	520

3x0.14 mm<sup>2</sup>    4-pin, M 12

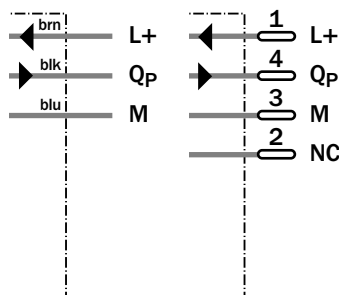

Technical Data		VL 12 -	1P2132	1P2430								
<b>Scanning range</b> , max. typ./on reflector	0.005...2.5 m / C110											
<b>Operating range</b>	0.005...2 m / C110 (∅ 80 mm)											
Light source <sup>1)</sup> , light type	LED, infrared light											
Light spot diameter	Approx. 100 mm at 200 cm											
Angle of dispersion, sender	Approx. 2.8°											
<b>Supply voltage V<sub>S</sub></b>	10...30 V DC <sup>2)</sup>											
Ripple <sup>3)</sup>	± 10 %											
Current consumption <sup>4)</sup>	≤ 20 mA											
<b>Switching outputs</b>	PNP, open collector: Q											
Output current I <sub>A</sub> max.	200 mA											
Light receiver, switching mode	Dark-switching											
Response time <sup>5)</sup>	≤ 5.0 ms											
Max. switching frequency <sup>6)</sup>	100/s											
<b>Connection types</b> cable	PVC, 2 m <sup>7)</sup> ; 3 x 0.14 mm <sup>2</sup> , ∅ 3.1 mm											
plug	4-pin, M12											
<b>VDE protection class<sup>8)</sup></b>	□											
Circuit protection <sup>9)</sup>	A, B, C, D											
<b>Enclosure rating</b>	IP 67											
<b>Ambient temperature T<sub>A</sub></b>	-25 °C...+70 °C											
<b>Weight</b>	Approx. 70 g inc. cable Approx. 35 g inc. plug											
<b>Housing material</b>	Nickel-coated brass housing/PA; Optics: PC											

- 1) Average service life 100,000 h at T<sub>A</sub> = +25 °C
- 2) Limit values
- 3) May not exceed or fall short of V<sub>S</sub> tolerances
- 4) Without load
- 5) Signal transit time with resistive load
- 6) With light/dark ratio 1:1
- 7) Do not bend below 0 °C
- 8) Reference voltage 50 V DC
- 9) A = V<sub>S</sub> connections reverse-polarity protected  
B = Inputs and outputs reverse-polarity protected  
C = Interference pulse suppression  
D = Outputs overload and short-circuit protected

**Scanning range and operating reserve**

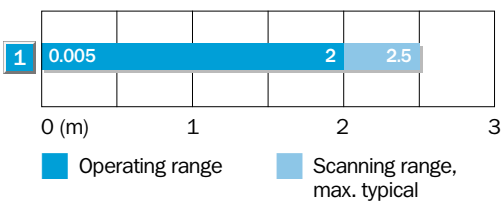

Reflector type	Operating range
1 C 110	2 m

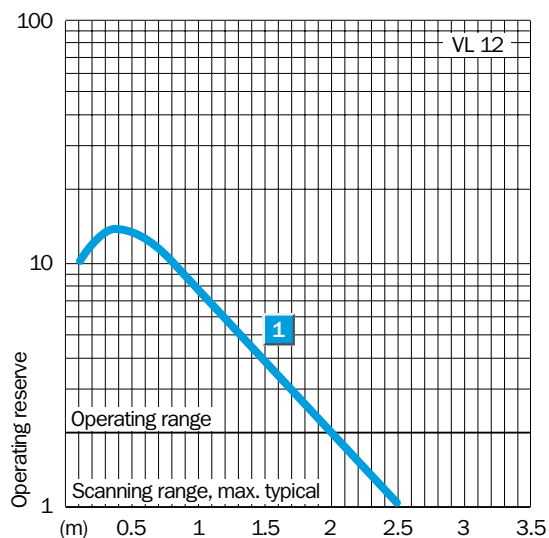

**Order information**

Type	Part no.
VL 12-1 P 2132	6 011 135
VL 12-1 P 2430	6 011 136

 **Scanning range**  
5 m

Through-beam photoelectric switches

- Robust metal housing
- Dark-switching
- Cable or plug connection
- Reverse polarity and short circuit protection

Dimensional drawing

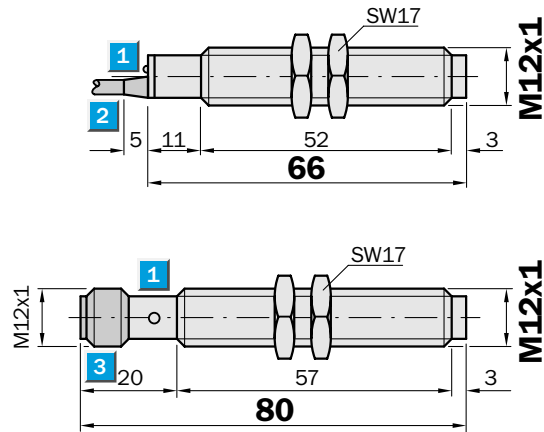

- 1** LED signal strength indicator, LED red (receiver VE 12 only)
- 2** Connecting cable
- 3** 4-pin, M 12 plug

Connection types

VS/VE12-1 P2132 VS/VE12-1 P2430

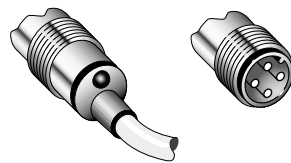

Sender	2 x 0.14 mm <sup>2</sup>	4-pin, M12
--------	--------------------------	------------

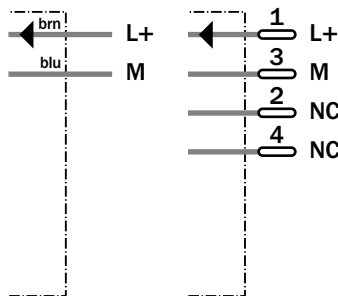

Receiver	3 x 0.14 mm <sup>2</sup>	4-pin, M12
----------	--------------------------	------------

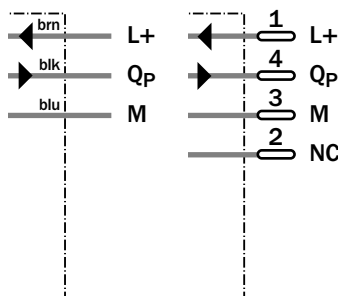

Accessories	page
Cable receptacles	496
Mounting brackets	510



Technical Data		VS/VE 12 -	1P2132	1P2430								
<b>Scanning range</b> , max. typical		5.0 m										
<b>Operating range</b>		4.0 m										
Light source <sup>1)</sup> , light type		LED, infrared light										
Light spot diameter		Approx. 350 mm at 4 m										
Angle of dispersion, sender		Approx. 3°										
Angle of dispersion, receiver		Approx. 20°										
<b>Supply voltage <math>V_S</math></b>		10...30 V DC <sup>2)</sup>										
Ripple <sup>3)</sup>		± 10 %										
Current consumption <sup>4)</sup>	sender	≤ 20 mA										
	receiver	≤ 20 mA										
<b>Switching outputs</b>		PNP, open collector: Q										
Output current $I_A$ max.		200 mA										
Light receiver, switching mode		Dark-switching										
Response time <sup>5)</sup>		≤ 10 ms										
Max. switching frequency <sup>6)</sup>		50/s										
<b>Connection types</b>	cable	PVC, 2 m <sup>7)</sup>										
	sender VS	2 x 0.14 mm <sup>2</sup> , Ø 3.1 mm										
	receiver VE	3 x 0.14 mm <sup>2</sup> , Ø 3.1 mm										
	plug	4-pin, M12										
<b>VDE protection class<sup>8)</sup></b>		□										
Circuit protection <sup>9)</sup>	sender	A, B										
	receiver	A, B, C, D										
<b>Enclosure rating</b>		IP 67										
<b>Ambient temperature <math>T_A</math></b>		- 25 °C... + 70 °C										
<b>Weight</b>	inc. cable	Sender and receiver each approx. 70 g										
	inc. plug	Sender and receiver each approx. 35 g										
<b>Housing material</b>		Nickel-coated brass housing / PA; Optics: PC										

- 1) Average service life 100,000 h at  $T_A = + 25 °C$
- 2) Limit values
- 3) May not exceed or fall short of  $V_S$  tolerances
- 4) Without load
- 5) Signal transit time with resistive load
- 6) With light/dark ratio 1:1
- 7) Do not bend below 0 °C
- 8) Reference voltage 50 V DC
- 9) A =  $V_S$  connections reverse-polarity protected  
B = Inputs and outputs reverse-polarity protected  
C = Interference pulse suppression  
D = Outputs overload and short-circuit protected
- 10) Part no. includes sender and receiver unit

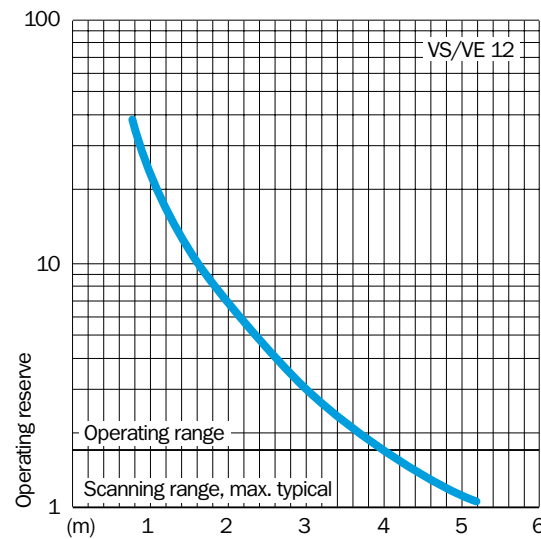
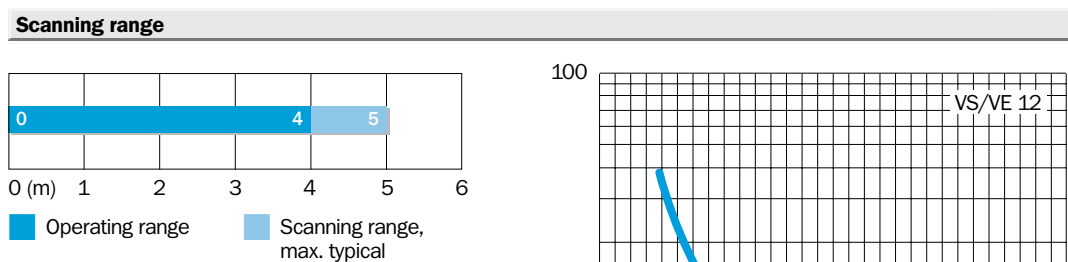

**Order information**

Type	Part no. <sup>10)</sup>
VS/VE12-1P2132	6 011 141
VS/VE12-1P2430	6 011 142