

WLG 12: Reflex light grids with eight light beams



outputs include checking the edges of material runs, and detecting and sorting bottles (measuring light grid).

Depending on the sensitivity setting, objects with a size of over 12.5 mm and at a distance of 1.5 m can be detected just as reliably as objects of just 6 mm at a distance of 0.4 m. The reliable detection of transparent objects such as glass, and reflective surfaces (thanks to polarising filters), is also possible.

The annoying thing about pipe ends, damaged pallets and other conveyed objects from a detection point of view is that their height or position can vary while they are being transported by an automatic conveyor system.

Early and reliable detection of, for example, a pallet as it enters a pallet stacker or lifting gear is, however, essential. These are typical examples of applications for the WLG 12 reflex light grid.

Eight parallel beams form a 100 mm high light grid. If one or more light beams are broken by an object, the WLG 12 generates an "object detected" switching signal (switching light grid). Further examples for the use of the WLG 12 with eight individual switching

Among the many features contributing to the WLG 12's simple commissioning and operation are:

- the visible red light of the sender LED, used as an alignment aid,
- programming objects to be detected using the "teach-in" method,
- the multifunction display indicating switching state, teach-in status and errors occurring during teach-in.

Two versions are available: with one switching output or with individual switching outputs for each of the eight light beams.

► Counting irregularly shaped objects, e.g. during metal production.

▼ Two WLG grids, installed horizontally, used to count objects before packaging.

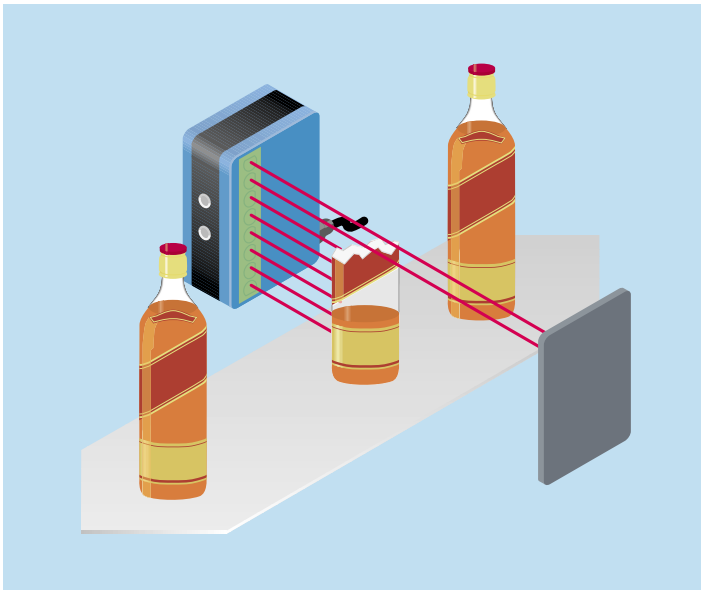
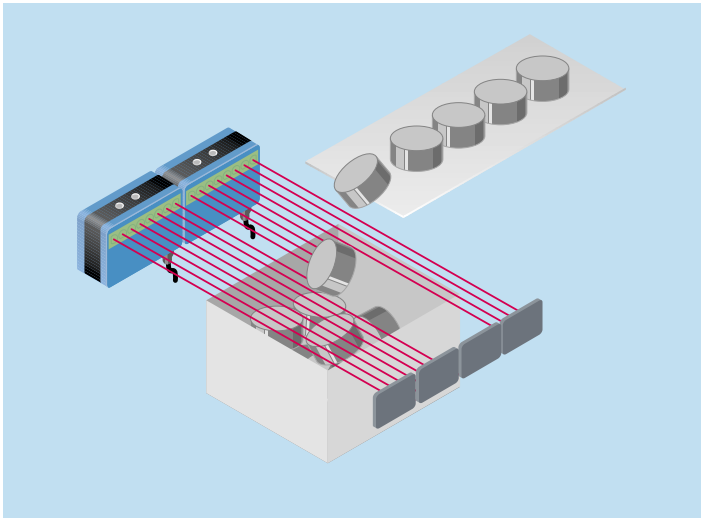

▲ The WLG also detects transparent objects such as bottles in sorting systems. Defective containers are reliably detected.



▲ With its eight parallel light beams, the WLG 12 reflex light grid can detect any damaged pallets.

Scanning range
0 ... 1.5 m

Reflex light grids

- Teach-in for optimum sensitivity adjustment
- Detection of objects from 6 mm diameter
- Short response time
- Red light as alignment aid
- Reliable detection of reflective objects



Dimensional drawing

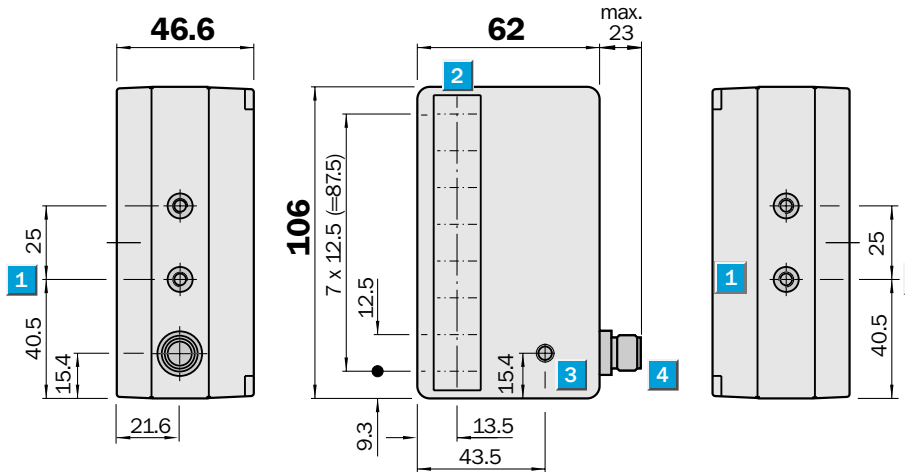

- 1 M5 threaded mounting hole, 6 mm deep
- 2 Optics
- 3 Multi-function indicators at front and top: reception indicator, contamination indicator, teach-in error
- 4 5-pin, M 12 plug or 2 m cable
- 5 Power indicator
- 6 Potentiometer for sensitivity adjustment

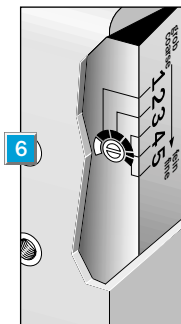
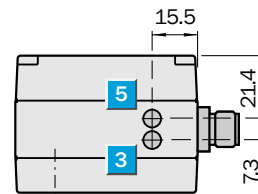

Choice of sensitivity range

Potentiometer setting	Resolution	Scanning range	Reflector
1	> 12.5 mm	1.5 m	2 x PL 80 A/PL 40 A
2	> 10 mm	1.2 m	2 x PL 80 A/PL 40 A
3	> 9 mm	1.0 m	PL 180 E01
4	> 7 mm	0.8 m	PL 180 E01
5	> 6 mm	0.4 m	PL 180 E01

Connection types

WLG 12-G 137 WLG 12-V 537 WLG 12-P 537

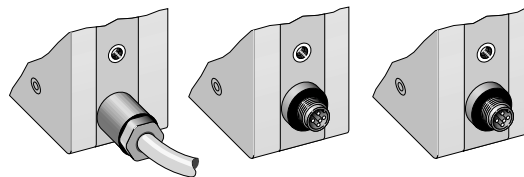

12-wire cable 5-pin, M 12 5-pin, M 12

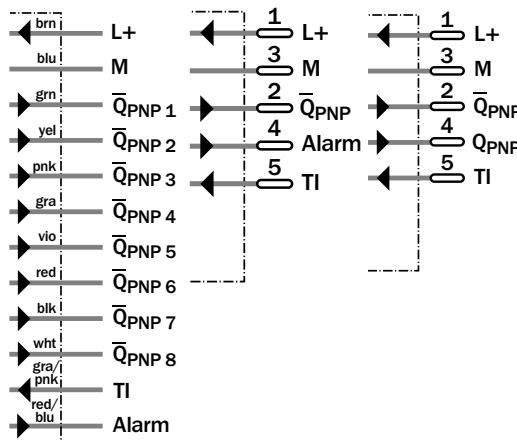

Accessories	page
Cable receptacles	496
Mounting brackets	510
Reflectors	520

Technical Data	WLG 12-	G 137	V 537	P 537							
-----------------------	---------	-------	-------	-------	--	--	--	--	--	--	--

Scanning range , max. typ./on reflector	1.5 m/to 2 x PL 40 A or 2 x PL 80 A			
Light source¹⁾, light type	Red light, pulsed			
Resolution, adjustable	6...12.5 mm (see table of settings)			
Light spot diameter	10 mm			
Distance to optic axis	12.5 mm			
Divergence of adjacent channels	Approx. 0.2 °			
Angle of dispersion of light beam	Approx. 0.4 °			
Supply voltage V_S	18...30 V DC ²⁾			
Ripple ³⁾	< 5 V _{SS}			
Current consumption ⁴⁾	Approx. 80 mA			
Switching outputs	PNP, 8 x \bar{Q} and alarm PNP, \bar{Q} and alarm PNP, \bar{Q} and Q			
Output current I _A max.	Total 100 mA + 100 mA for alarm 100 mA per output			
Output voltage HIGH	V _S - (≤ 2 V, at I max.)			
Output voltage LOW	0 V			
Response time ⁵⁾	0.6 ms			
Max. switching frequency ⁶⁾	850 Hz			
Alarm output	Alarm is activated acc. to teach-in procedure, if at least one of the light beams is damped such that the required level of functional safety is not achieved.			
Teach-in (TI)				
Teach-in minimum time	Approx. 10 ms			
Teach-in activation time	Approx. 200 ms			
Connection type	2 m, 12-wire cable ⁷⁾ 5-pin, M 12 plug			
VDE protection class⁸⁾	□			
Circuit protection⁹⁾	A, B, C			
Enclosure rating	IP 67			
Ambient temperature T_A	Operation -25 °C ... +55 °C Storage -25 °C ... +75 °C			
Weight	Approx. 230 g			
Polarisation filter				
Housing material	Fibreglass reinforced plastic			

1) Average service life 100,000 h at T_A = +25 °C
2) Limit values

3) May not exceed or fall short of V_S tolerances
4) Without load

5) Signal transit time with resistive load
6) With light/dark ratio 1:1
7) Do not bend below 0 °C
8) Reference voltage DC 50 V

9) A = V_S connections reverse-polarity protected
B = Outputs Q and \bar{Q} short-circuit protected
C = Interference pulse suppression

Commissioning	Notes
---------------	-------

When the W 12 is first commissioned, a teach-in procedure must be carried out.

- Set potentiometer to required resolution (see table), delivery condition 10 mm.
- Trigger teach-in procedure with free light path through control wire (Connect T1 to earth)

The sensitivity range should be selected in a voltage-free condition. In the event of temperature fluctuations > 15 °C, adjustment or contamination, a new teach-in process must be carried out.
The switching threshold that has been taught is maintained on loss of voltage.

Order information	
Type	Part no.

WLG 12-G 137	1 016 046
WLG 12-V 537	1 016 045
WLG 12-P 537	1 015 798