



NEW

Series i10
Series i100
Series i1000
Series T4000



P R O D U C T I N N O V A T I O N

Switch to safety and performance.
Safety interlocks
with and without magnetic release.

SICK

There are many ways to safeguard machines.

The alternative to opto-electronic solutions: SICK's safety interlocks.

SICK's new safety interlocks now provide the alternative to opto-electronic protective systems – equipped with all the quality features that are typical of SICK's products. With their intelligent technology, small size, great variety and superlative cost-effectiveness, SICK's safety interlocks provide all the options for the most varied of applications.

Merciless, hot and aggressive – but our interlocks are not so easily shaken.

Extremely harsh environmental conditions, external effects such as shocks and vibration, and frequent operation are demands that SICK's safety interlocks can easily handle. They remain alert and on duty throughout the hard industrial day-to-day grind: accurate opening and closing is consistently guaranteed.

From a technical point of view the interlocks are among the most mature of all systems. At the same time they are truly high-tech. Integrated evaluation electronics make external switching relays unnecessary. SICK's safety interlocks are available in plastic or metal versions. A non-contact safety interlock using transponder technology rounds off the programme.

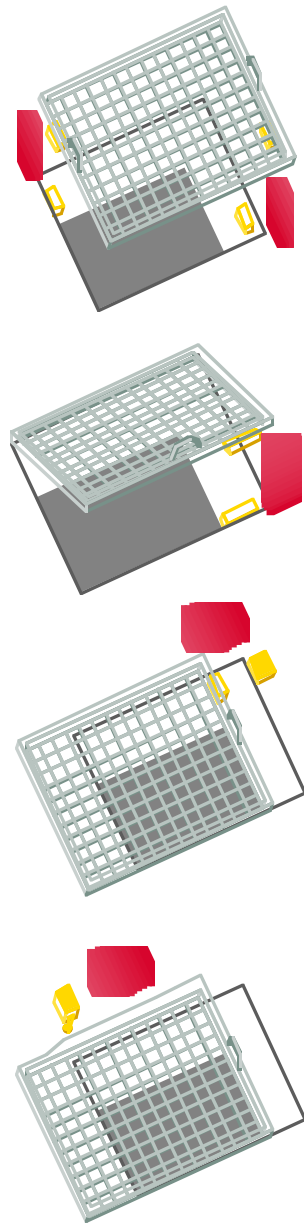

ADVANTAGES AT A GLANCE

- Small sizes
- Safety categories 1–4
- All environmental conditions
- High enclosure ratings (up to IP 67)
- Great flexibility
- Large variety of fittings
- Approval according to BG, BIA, CSA, SAQ, SUVA, and UL

AREAS OF APPLICATION

- Mechanical engineering
- Metal processing
- Plant construction
- Automotive industry
- Robotics and automation
- Food processing and drinks

With four product lines, SICK offers a wide range of safety interlocks for automation, handling and assembly functions.



We open all doors.



Low duty

Plastic series i10 – i10 Lock – i11 mini

Interlocks made of recyclable plastic. 8 approach directions that are quickly and easily adjusted. Small, compact shapes allow a wide variety of applications.

This series of interlocks is available with various switching members and with or without locking.



Variably adjustable approach direction, actuator entry direction and switching direction make SICK plastic interlocks highly flexible components.

Heavy duty

Metal series i100 – i100 Lock

Developed and manufactured for use in mechanical engineering and plant construction. These devices are proof against even the harshest of environmental conditions and are distinguished by the maximum security they offer, their great strength, and their resistance to corrosion. Suitable for safety categories 1–4.



Robust and compact housings withstand hard operating conditions.

Ultra heavy duty

High-end series i1001/2 – i1001/2 Lock

The modular solution for extreme demands. This safety system has the right modules for every application. The inclusion of an “arresting key” allows new configurations to be implemented in your safety facilities.



Unique module concept with trapped-key transfer system for maximum personnel protection.

Non-contact

Electronically encodable series T 4000

This safety interlock uses an electronically encodable actuator that prevents manipulation. It is used wherever high standards of hygiene must be maintained. Also optimal for large and heavy doors and ideal where there is a lot of dirt.



Can be used wherever there are strict hygiene regulations, imprecise door alignments, or heavy vibrations.



ANALYSIS AND SELECTION

SICK would be pleased to assist you in making a risk analysis and selecting the optimal safety interlock system.

Extremely compact and remarkably versatile.



Series i10 – i10 Lock – i11 mini with plastic housings

This versatile line of interlocks has a high-quality, recyclable plastic housing that is the most compact and the lightest of their class. Here you will find reliable security based on sophisticated technology – SICK's qualities precisely.

4 lateral approach directions in addition to 4 from above are quickly and easily

adjusted. The small interlock width allows trouble-free mounting on 30 mm and 40 mm profiles. But the i10 – i10 Lock – i11 mini series' small and light structure is not their only attribute. Their robust, versatile technology is also presentable. Switching elements with 1 to 4 switching members provide flexible connection. From now on you only need one interlock for a variety of applications.

Advantages at a glance:

- Can be mounted on 30 mm and 40 mm profiles
- 4 lateral approach directions
- 4 approach directions from above
- Compact housing
- Small interlock width
- Variable switching members
- Approvals: BG, CSA, SAQ, SUVA, UL

i10 – i10 Lock – i11 mini SERIES OF INTERLOCKS	
Frequency of operation	low – average
Environmental conditions	normal
Lock	single
Encoding	via key
Functions	opening, closing, locking

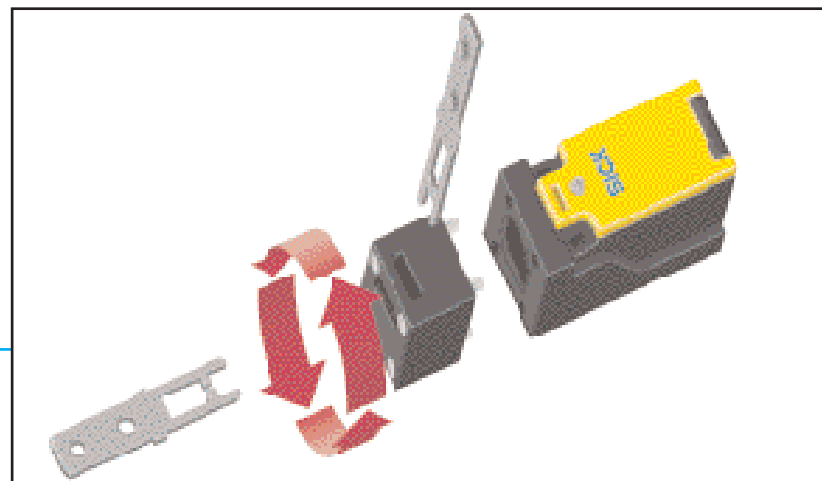

A pre-requisite for modern automation: The i10 – i10 Lock – i11 mini series of plastic interlocks.

One for all – up to safety category 4.



Series i100 – i100 Lock with metal housings

Sophisticated technology forms the basis for the greatest reliability and precision – independent of external influences. Here too, SICK's safety interlocks again demonstrate their excellence. The i100 – i100 Lock series was developed for the harshest conditions in mechanical engineering and plant construction. The series have robust metal housings, and the high-quality materials used for the plunger, driving mechanism and seals guarantee a long life.

i100 – i100 Lock metal interlocks are available in Category 1 (switching member and actuator form one unit) and Category 2 (switching member and actuator do not form a unit). Versatile convertibility of the approach direction, actuator entry direction and switching direction mean that the interlocks are components that can be used anywhere for protecting people and machines.

Advantages at a glance:

- Light-metal diecast housing
- Position interlock according to EN 50041
- Safety categories 1 – 4
- Variable approach direction
- Variable actuator entry direction
- Switching direction left/right

i100 – i100 Lock SERIES OF INTERLOCKS	
Frequency of operation	high
Environmental conditions	shock vibration heat
Lock	double
Encoding	via key
Options	open, closing, locking

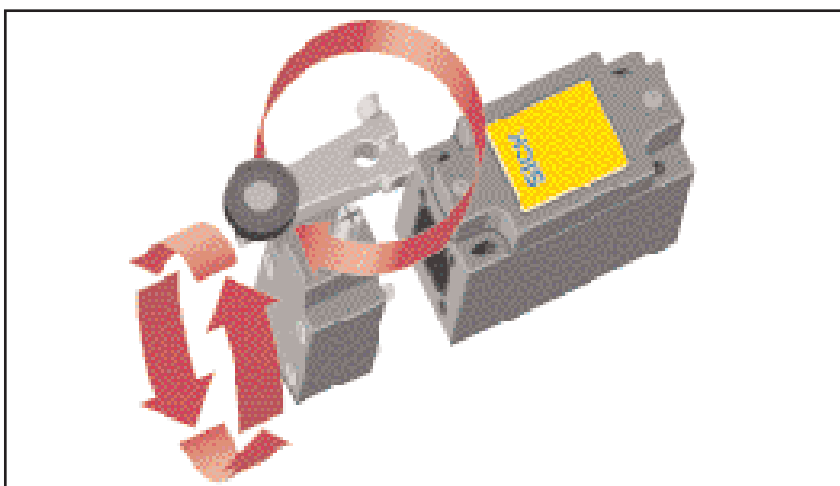

Robust light-metal diecast housing guarantees long life.

Modular safety that leaves nothing to chance.



High-end series i 1001/2 – i 1001/2 Lock: Modules for all applications.

The i1000 safety system is not only highly robust but also extremely modular. It is based on the 2 basic elements 1001 – 1002. These can be adapted to the particular application using a safety-key adapter.

Simple control using key-actuated interlock.

Key-actuated interlocks can be used for programming machines, for example for test and set-up modes. They guarantee the operator maximum labour protection.

The i 1000 safety system. Advantages at a glance:

- Unique modular concept
- Great variety of configurations
- Self-adjusting of alignment errors
- Conforms to the norms EN-954-1, EN 1088, EN 292 and EN 1050
- Trapped-key transfer system
- Encodable with locking and without key with different access rights (general and section keys)
- Cannot be forced open
- Simple mounting
- IP 67 enclosure rating

i 1001/2 – i 1001/2 Lock HIGH-END SERIES

Frequency of operation	very high
Environmental conditions	extreme stress alignment errors vibration, heat complex locking positions
Lock	triple
Encoding	via key
Functions	opening/closing, locking, key/enable

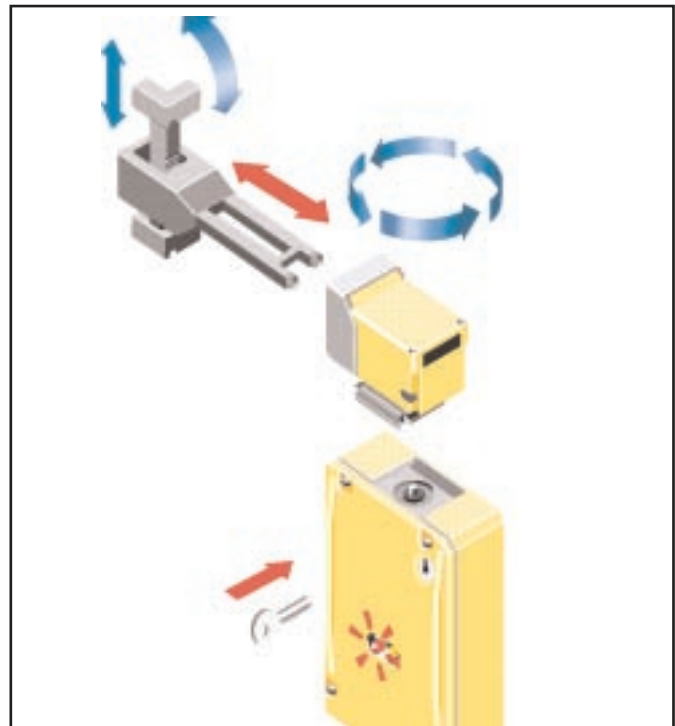

i 1002 Lock

The system modules.

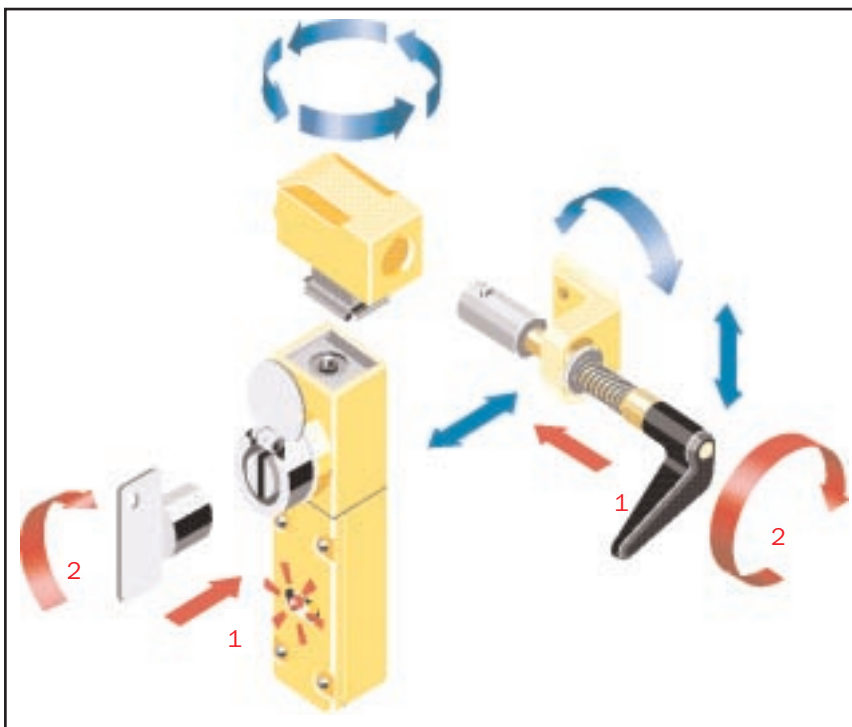
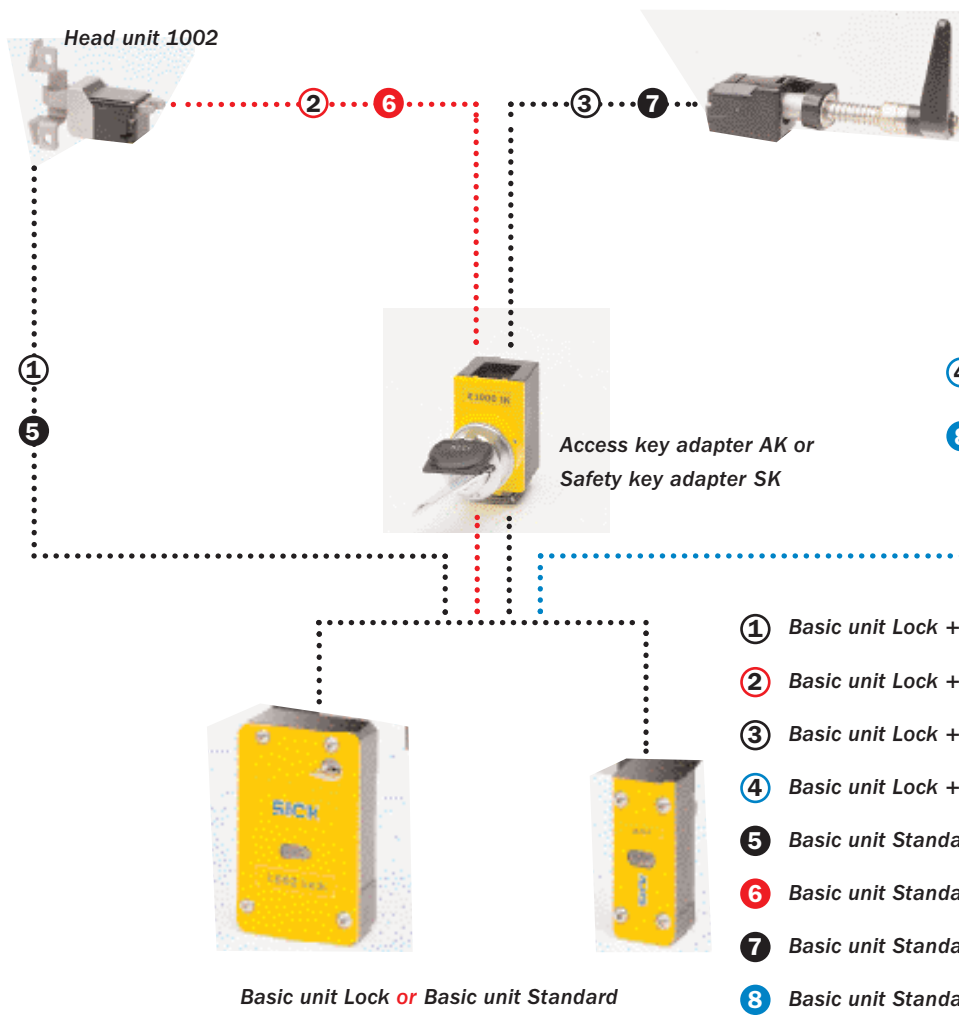

Basic unit Standard + key adapter + head unit 1001



Option: Enabling or programmer key

Your key to increased labour protection and flexibility.

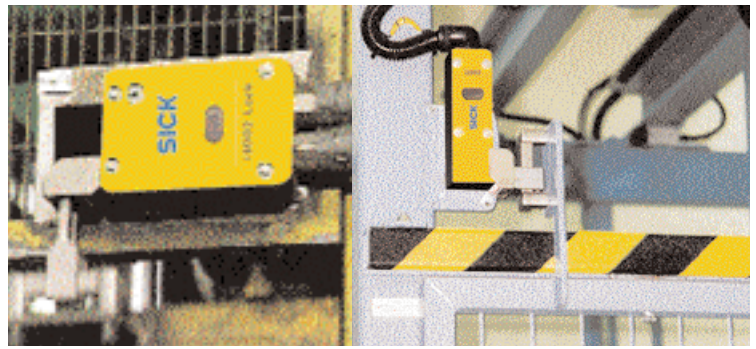

Enable function with trapped-key system.

Application example:
Basic unit Lock + head unit 1002 + safety key adapter.
In enable mode nobody can set the machine in motion from outside. The machine is started from inside with the safety key.

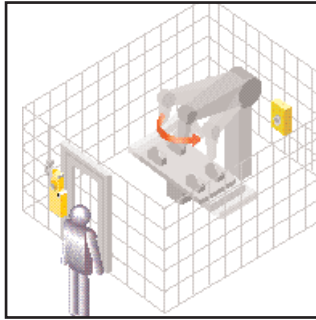

Plant in action, door closed, key inserted

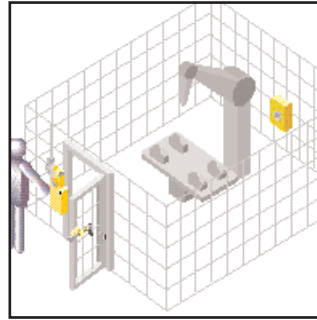

Key is removed, plant comes to standstill, door can be opened

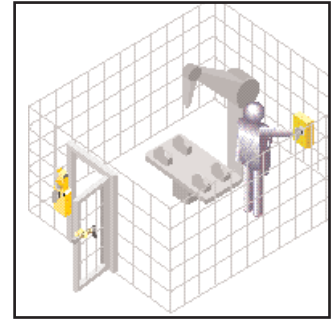

Person enters, key inserted inside, plant runs in enable mode



Access function:

Application example:
Basic unit standard + head unit 1001 + access key adapter.
Only those with an access key can gain access to the machine.

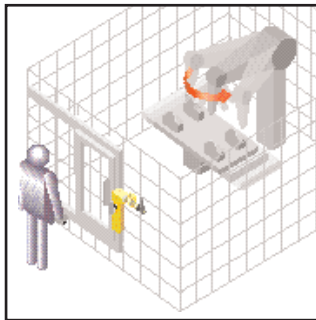

Plant in action, no key inserted

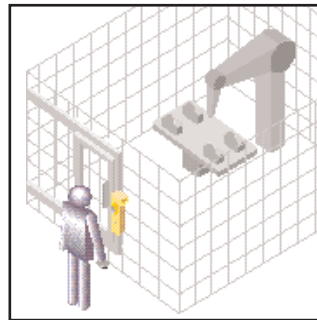

Key is inserted, plant comes to a standstill

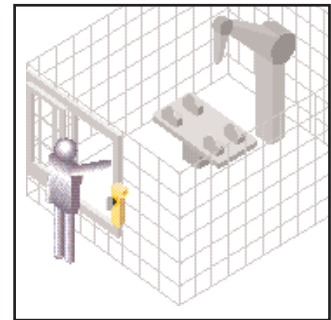

Door can now be opened



Safety actuator with restart function:

Application example:
Basic unit standard + head unit 1001. The door may only be opened or closed deliberately. Accidental closure of the door does not trigger a machine start.

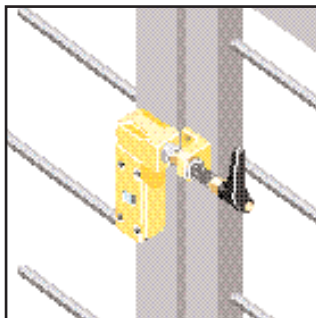

Door closed and locked

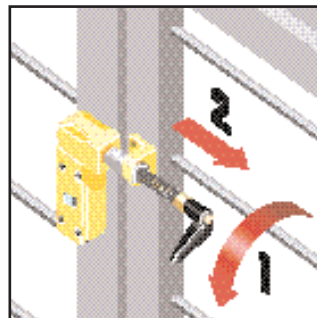

Door closed and unlocked

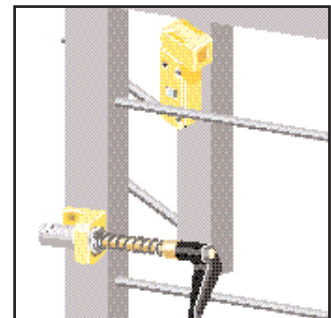

Door open

Accepts harsh conditions, bars manipulation.



T 4000 series non-contact interlocks

With the T 4000 non contact line of interlocks you remain independent of external influences, and most effectively protect your plant from manipulation. For this interlock operates with an electronic, uniquely encodeable actuator, a technology that has been successfully used for security dead locks in the automotive industry for many years. T 4000 interlocks are the ideal solution wherever exact door alignment is impossible, machine doors vibrate a lot, or for heavy and large doors. Actuators without batteries guarantee continuous, service-free operation.

Advantages at a glance:

- Ideal where there are strict hygiene regulations (e.g. in the food processing industry)
- For imprecise door alignment
- When there is a lot of vibration
- For large and heavy doors
- High security against manipulation
- Conforms to control category 4

T 4000 SERIES OF INTERLOCKS	
Frequency of operation	high
Environmental conditions	aggressive hot vibration
Lock	by encoding
Encoding	electronic
Functions	opening/closing

Ideal for large and heavy doors as well as increased hygienic demands: the T 4000 series of interlocks.

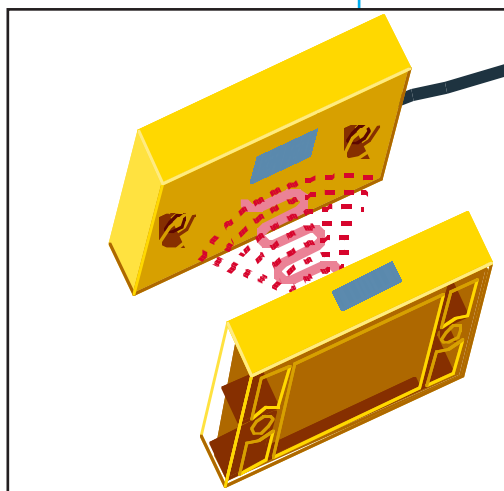

E 100 enabling interlock

Employed as hand-operated command units these interlocks allow work to be carried out in the hazardous areas of machines and plant. In "manual mode", the function of protective systems is cancelled under certain conditions. This allows access to hazardous areas so that programming, adjustment and commissioning work may be carried out.

Enabling interlocks in various designs allow safer work in hazardous areas.

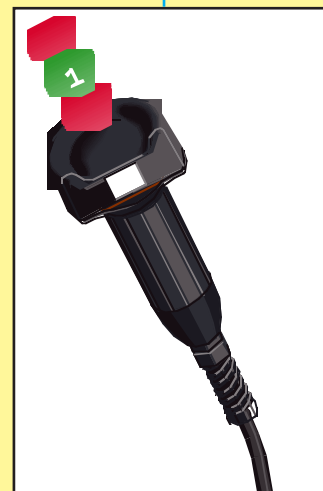

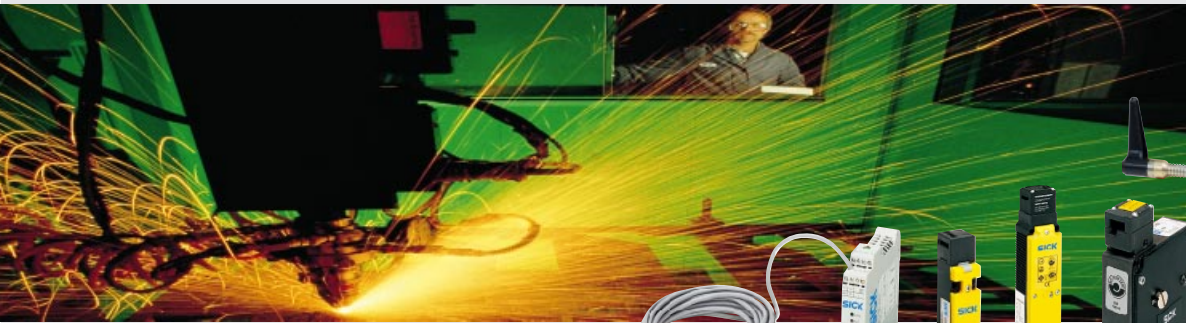

Safety Interlocks by SICK.

SICK

Which interlock solution do you require?

The following selection guide provides an overview of basic problem definitions and suggests particular solutions. Clear page references simplify use of the catalogue.

You are looking for a simple, compact interlock solution with a high degree of variability

... with solenoid release?

Detailed information can be found on **pages 14–16.**

... without solenoid release?

Detailed information can be found on **pages 17–22.**

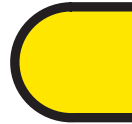

You are looking for a solution that can withstand extreme conditions such as heat, shock or vibration

... with solenoid release?

Detailed information can be found on **pages 29–38/61–68.**

... without solenoid release?

Detailed information can be found on **pages 39–54/79–80.**

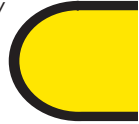

Contents

The most modern interlock technology for application flexibility	6
Designed for practicality	7
Switch to safety and efficiency. SICK Safety Interlocks	8
Low duty with solenoid release	11
SICK – your specialist partner in safety matters	12
i10 Lock Safety Interlock series	14
i10 Lock series ordering table	16
Low duty without magnetic release – i10 and i11 mini series	17
i10 Safety Interlock series	18
i11 mini Safety Interlock series	20
i10 and i11 mini series ordering tables	22
Low duty accessories	23
iE 10 and iE 10 Lock series accessories	24
iE 11 series accessories	26
iE 10 and iE 11 series ordering tables	27
Heavy duty with solenoid release	29
i100 Lock Safety Interlock series (head on left – cable entry)	30
i100 Lock Safety Interlock series (head on right – cable entry)	32
i100 Lock Safety Interlock series (head on left – device plug)	34
i100 Lock Safety Interlock series (head on right – device plug)	36
i100 Lock series ordering table	38
Heavy duty without solenoid release	39
Construction – function – details	40
i100 R 1 Safety Interlock series	42
i100 R 2 Safety Interlock series	44
i100 P 1 Safety Interlock series	46
i100 P 2 Safety Interlock series	48
i100 S 1 Safety Interlock series	50
i100 S 2 Safety Interlock series	52
i100 series ordering table	54
Heavy duty accessories	55
Actuator accessories	56
Plug accessories	58
iE 100 series ordering table	59

[Contents continue on page 5](#)



Are you looking for an interlock solution that meets strict hygiene regulations?

... with solenoid release?

Detailed information can be found on **pages 14–15.**

Detailed information can be found on **pages 79–86.**

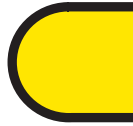

Are you looking for a solution for large, heavy doors with alignment errors?

... with solenoid release?

Detailed information can be found on **pages 61–68.**

... without solenoid release?

Detailed information can be found on **pages 69–74/79–86.**

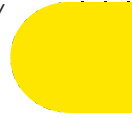
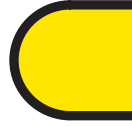

Are you looking for a solution with a secure enable/service mode?

Detailed information can be found on **pages 87–90.**

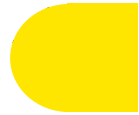

Are you looking for relevant regulations and standards?

Detailed information can be found on **pages 91–97.**

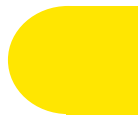

Are you looking for a solution for a complex locking situation?

... with solenoid release?

Detailed information can be found on **pages 61–68.**

... without solenoid release?

Detailed information can be found on **pages 69–75.**

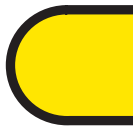

Are you looking for a locking solution for robot cells with rapid and frequent access?

... with solenoid release?

Detailed information can be found on **pages 61–68.**

... without solenoid release?

Detailed information can be found on **pages 69–75.**

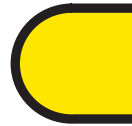

Do you require operating or service personnel to be granted authorised access to the machine?

... with solenoid release?

Detailed information can be found on **pages 75–77.**

... without solenoid release?

Detailed information can be found on **pages 75–77.**

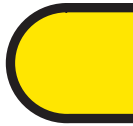

Contents



Ultra heavy duty with solenoid release	61
Function – details – options	63
i1002 Lock Safety Interlock series	64
i1001 Lock Safety Interlock series	66
i1001 Lock and i1002 Lock series ordering table	68
Ultra heavy duty without solenoid release	69
i1001 Safety Interlock series	70
i1002 Safety Interlock series	72
i1001 and i1002 series ordering table	74
Modular options	75
Ultra heavy duty accessories	77
Ordering table	77
T 4000 Non-contact Safety Interlocks	79
T 4000 Non-contact Safety Interlock	80
T 4000 Non-contact Safety Interlock	Relay control unit
	82
T 4000 Non-contact Safety Interlock	Detector head
	83
T 4000 Non-contact Safety Interlock	Actuator
	84
T 4000 ordering table	86
E 100 Enabling Switch	87
Enabling switch	88
E 100 Enabling Switch	3 stage/dual channel
	89
E 100 ordering table	90
Norms and standards	91
Risk analysis – control categories	92
Control categories	94
Regulations – norms – recommendations	95
Colour coding	97
Definition of terms	98
Switching elements	100
Safety interlocks – categories	102
Construction – function – details	103

A guaranteed future from an experienced company.

The most modern interlock technology for application flexibility

Safety components offer a great deal. But only a few manufacturers build them in such a way that they can fulfil both today's practical demands and those of the future. In order to ensure that our safety interlocks can do the job properly, we have put more into them than just SICK's well-known quality and reliability. Namely, the experience and knowledge gained from thousands of applications in the most varied of industries. SICK's presence on Europe's leading safety committees guarantees that SICK is always at the forefront of safety technology. Those who choose to go with SICK can profit from this extensive knowledge.



We ensure safe access by providing a suitable interlock for every application.

Extremely harsh environmental conditions, external effects such as shocks and vibration, and frequent operation are demands that SICK safety interlocks can easily handle. They remain alert and on duty throughout the hard industrial day-to-day grind: accurate opening and closing is consistently assured. From the technical point of view, the switches belong to the most mature of all the systems. At the same time they are truly high-tech.



Designed for practicality.

It's safe to say: even more possibilities.

SICK's modern interlock expertise opens countless new possibilities for complete safety. Their flexibility for use in new applications has been considerably improved as a result of improved equipment,

stronger housings and the use of modern switching technology. You are aware of the complex demands that you make of an interlock, and you assess the duties that the door interlock has to perform in everyday usage. Our aim is to find an interlock solution that is individually tailored to suit your plant or machine.

SICK safety interlocks are available in low duty, heavy duty, ultra heavy duty and non-contact versions.

Which interlock solution do you require?

	i10/i10 Lock/i11 mini	i100/i100 Lock	i1000/i1000 Lock
Frequency of operation	low – average	high	very high
Environmental conditions	normal	shock vibration heat	extreme loads alignment errors vibration, heat complex locking situations
Lock	single	double	treble
Encoding	via key	via key	via key
Function	opening/closing, locking	opening /closing, locking	opening /closing, locking, with key/enable functions

T 4000	E 100
high	low
aggressive heat vibration	shock heat deformation
–	–
electronic	–
opening /closing	3 stage manual enabling function

Advantages at a glance:

- small sizes
- safety categories 2–4
- all environmental conditions
- high IP enclosure ratings (up to IP 67)
- great versatility
- large variety of fittings
- approval according to BG, BIA, CSA, SAQ, SUVA, UL



Switch to safety and efficiency. Safety Interlocks by SICK.

Low Duty



i10 / i10 Lock / i11 mini plastic series

This versatile line of switches have a high-quality, recyclable plastic housing that is the most compact and the lightest of their class. Here you will find reliable safety based on sophisticated technology – SICK qualifies precisely.

4 lateral approach directions in addition to one from above are quickly and easily adjusted. The small interlock width allows trouble-free mounting on small profiles.

But the i10/i10 Lock/i11 mini series' small and light structure is not their only attribute. Their robust, versatile technology is also outstanding. Switching elements with two to four switching members

provide flexible connection. From now on you only need one interlock for a variety of applications.

Advantages at a glance:

- can be mounted on 30–40 mm profiles
- 4 lateral approach directions
- 1 approach direction from above
- compact housing
- easy connection
- variable switching members
- approvals: BG, CSA, SAQ, SUVA, UL
- with locking (i10 Lock)
- up to 3 cable entries

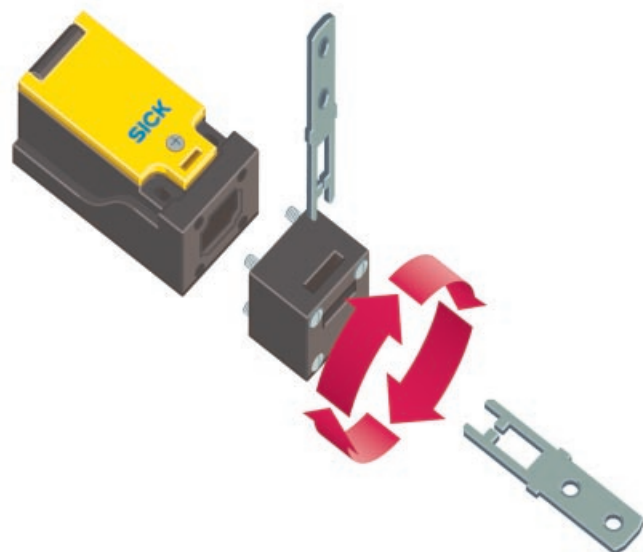

Heavy duty



i100 / i100 Lock metal series

Sophisticated technology forms the basis for the greatest reliability and precision – independent of external influences. Here too, SICK's safety interlocks again demonstrate their excellence. The i100 series was developed for the harshest conditions in mechanical engineering and plant construction. This line has metal housings, and the high-quality materials used for the plunger, driving mechanism and seals guarantee a long life.

A C-rail ensures absolute protection against manipulation. i100 metal switches are available in category 1 (switching member and actuator form one unit) and category 2 (switching member and actuator do not form a unit).

Versatile convertibility of the approach direction, actuator entry direction and switching direction mean that the switches are components that can be used anywhere for protecting people and machines.

Advantages at a glance:

- Light-metal die-cast housing
- Position switch according to EN 50041
- Safety categories 1–4
- Variable approach direction
- Variable actuator entry direction
- Switching direction left/right
- Indicator light

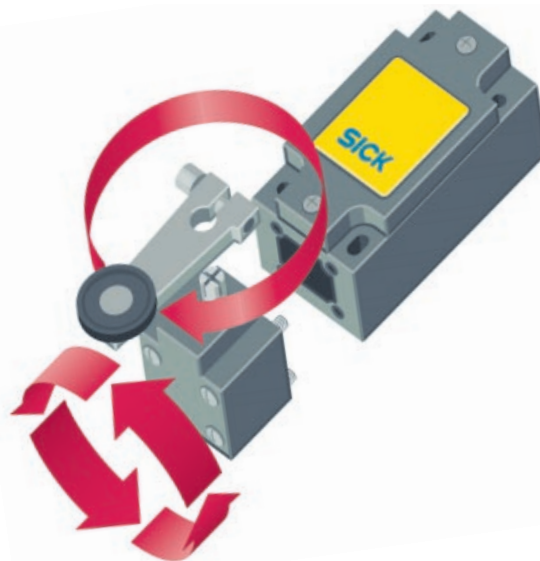

Ultra heavy duty



i1000 / i1000 Lock high-end series

The modular solution for extreme demands. This safety system offers suitable modules for every application.

The inclusion of an “arresting key” allows you to employ new configurations in your safety facilities.

Advantages at a glance:

- unique modular concept
- great variety of configurations
- self-adjusting of alignment errors
- conforms to the norms EN-954-1, EN 1088, EN 292 and EN 1050
- trapped-key transfer system
- encodable with locking and without key with differing access rights (general and section keys)
- cannot be forced open
- simple mounting
- IP 67 enclosure rating

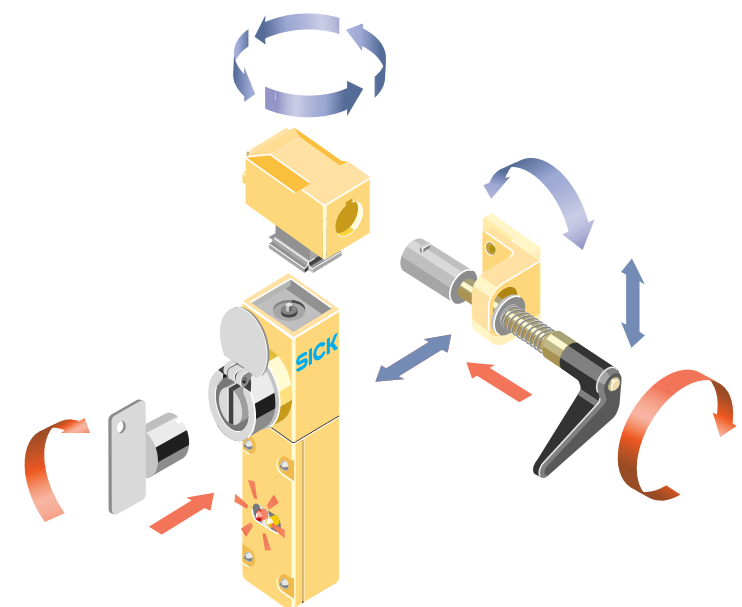

Non-contact interlocks



**T 4000
series**

With the T 4000 non-contact range of switches you remain independent of external influences, and therefore most effectively protect your plant from manipulation.

The T 4000 switch operates with an electronic, uniquely encoded actuator. This technology has been successfully used in the automobile industry for years to prevent car thefts. T 4000 switches are the ideal solution wherever exact door alignment is impossible, machine vibration, or for heavy and large doors. Actuators without batteries also guarantee continuous, service-free operation.

Advantages at a glance:

- Ideal where there are strict hygiene regulations (e.g. in the catering industry)
- For imprecise door alignment
- When there is a lot of vibration
- For large and heavy doors
- High security against manipulation
- **Fulfils control category 4 to EN 954-1**

Enabling switch



**E 100
enabling switch**

Employed as hand-operated command unit these switches allow the operation of machines and plant in hazardous areas. In the "manual operation" operating mode, the function of protective systems is cancelled under certain conditions. This allows access to hazardous areas so that programming, adjustment and commissioning work may be carried out.



Low duty with solenoid release

A door interlock with a robust, compact housing, its in-line design providing a versatile solution to many applications.

Use

Necessary wherever the machine stop time is *greater* than the access time.



SICK – Your Specialist Partner for Safety Equipment

The new safety interlocks offer important advantages

- Fully insulated ☐
- Actuator head can be orientated in 4 different lateral approach directions quickly and easily plus
- One approach direction from above
- Straight through key opening in the actuator head stops build up of debris
- All plastic materials identified to enable recycling
- Actuator made of stainless steel
- Actuator with increased overtravel (optional)
- Large variety of types with different switching elements

Type Series i10

- High 1200 N hold to close retention force in position "guard locked"
- Low stocking costs due to symmetrical housing
- 3 cable entries (PG 13.5)
- Slim line housing (39 mm), enables easy fitting to aluminium profiles
- Approvals for BG, CSA, SAQ, SUVA, UL

Type Series i10

- High 15 N hold to close retention force eliminates the need for separate retaining device
- Wide 4 mm fitting tolerance of key and interlock enables ease of assembly
- Fixing to EN 50047 or alternative fitting with 40 mm hole spacing
- Slim line housing (35 mm), enables easy fitting to aluminium profiles
- Approvals for BG, CSA, SAQ, SUVA, UL

Type Series i11 mini

- High 10 N hold to close retention force eliminates the need for separate retaining device
- Wide 4 mm fitting tolerance of key and interlock enables ease of assembly
- Fixing to EN 50047
- Slim line housing (29 mm), enables easy fitting to aluminium profiles
- Approvals for BG, CSA, SAQ, SUVA, UL pending

All safety interlocks have an additional approach direction from above



SICK offers Safety Interlocks type series i10 Lock with a standard 4 contact switching element:

- **4 contact switching element (standard)**
3 NC + 1 NO
- **other switching elements**
on demand

The new 4 contact switching element offers important advantages:

- Various circuit configurations
 - ➔ only one interlock for several applications
- Installation in the approved SICK housing
 - ➔ no conversion problems
 - ➔ conventional housing and drilling dimensions
- Reduction of type diversity
 - ➔ giving reduced stocking costs
- Redundant (twin-channel) integration into the safety circuit through the use of two electrically separated positive opening NC-contact elements. In addition there is the possibility of a redundant integration into safety circuit when wiring several safety interlocks in series.
 - ➔ increased safety for the user
 - ➔ attainment of high control category
- Approvals for BG, CSA, SAQ, SUVA, UL

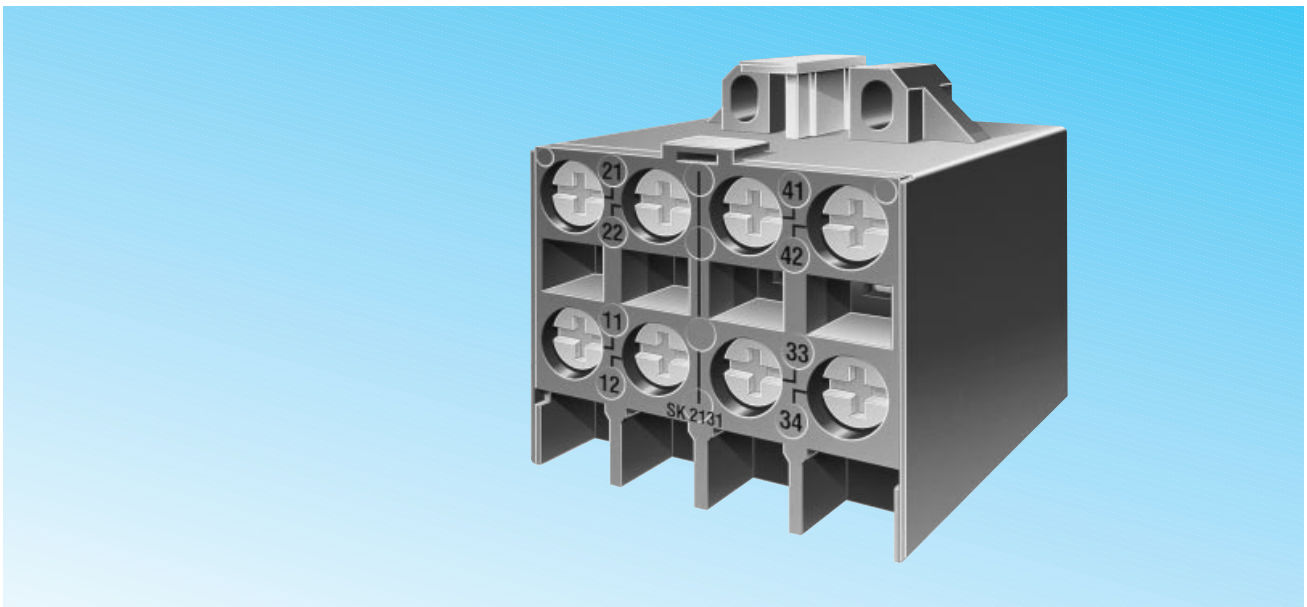

Safety Interlocks

Series i10 Lock

Housing:	Reinforced thermoplastic	
Connection:	Type i10...1	Cable entry
	Type i10...2	Plug connector SR 11
Switching elements:	4 contacts	
	Door contact	



Explosive area zone 2

Dimensional drawing Type i10...1

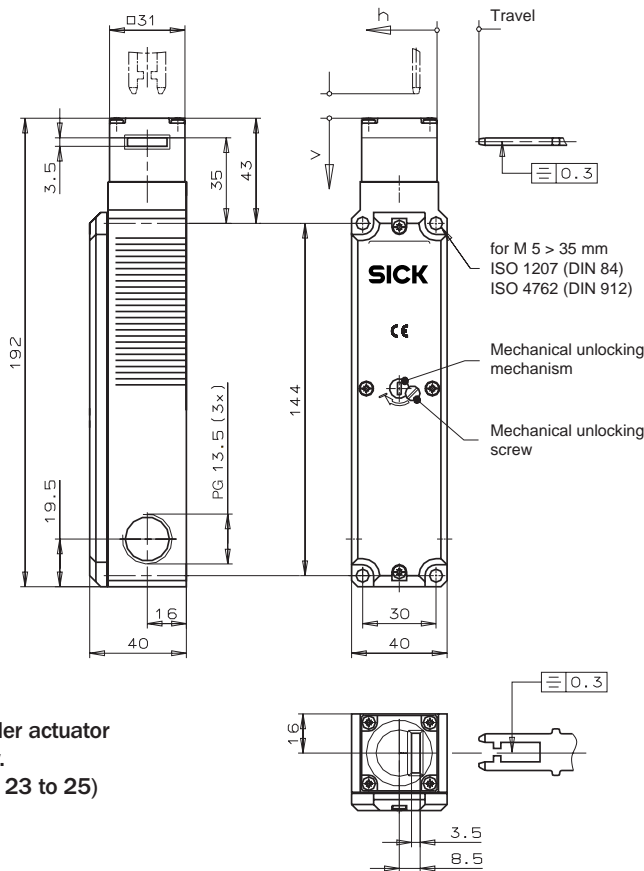

Please order actuator separately.
(See page 23 to 25)

Dimension drawing Type i10 Lock...2

Please order actuator and plug connector separately.
(See page 58)

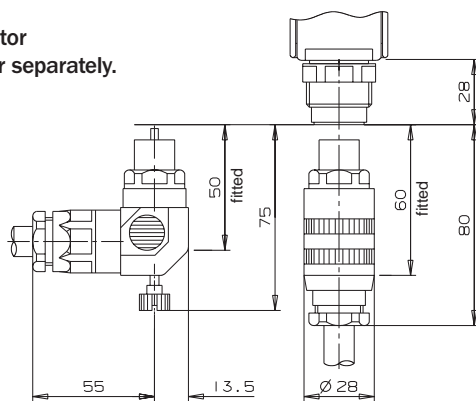

Warning

The complete safety interlock must be replaced in the event of faults.

Installation notes

The safety interlock and actuator must be assembled for installation purposes. The actuator must be positively connected with the mounting surface, e.g. by using safety screws or by welding, riveting, pinning. The safety interlock must not be used as an end stop.

Switching element

2131 Dependent action contact element, 2 positively driven NC contacts + 1 NO + 1 NC as door contact

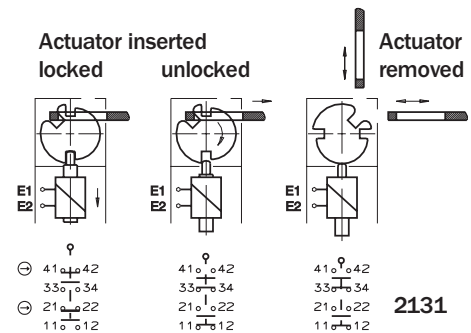

Locking methods

- i10 Lock M...: Actuator inserted, mechanically locked, unlocking by applying voltage.
- i10 Lock E...: Locking by applying voltage.

Mechanical unlocking mechanism

Safety interlocks can be unlocked by means of the mechanical unlocking mechanism in the event of power failure, for example. The mechanical unlocking mechanism has to be sealed to prevent manipulation (for example with sealing lacquer).

Changing the approach direction

The actuator head can be turned to the desired approach direction after undoing the fixing screws. Manufacturer setting is approach direction A.

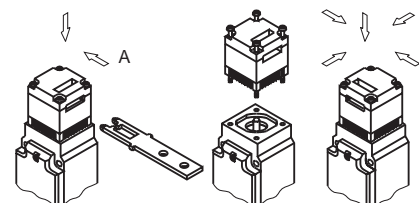

Technical data

Parameter	Value	Unit
Housing material	Reinforced thermoplastic	
Environmental protection to IEC 529	IP 65	
Mounting position	optional	
Mechanical service life	10 ⁶ Switching cycles	
Ambient temperature	- 25 to + 55	°C
Approach speed max.	20	m/min
Retaining force in locked condition	1200	N
Switching element	2131	
Contact elements	2 NC ⊖ + 1 NO + 1 NC	
Switching principle	Dependent action contact element	
Rated voltage U _i	i10...1, U _i = 250 i10...2, U _i = 50	V ≅
Utilization category to IEC 947-5-1	AC-15 U _e 230 V I _e 6 A / DC-13 U _e 24 V I _e 6 A	
Switching voltage min.	12	V
Switching current min. at 24 V	10	mA
Contact material	Silver alloy, gold flashed	
Connection type i10...1	Screw terminal, PG 13.5	
Connection type i10...2	Plug connector SR 11, cable diameter 8–10 mm	
Wire cross-section max., i10...1	1.5	mm ²
Short-circuit protection (control circuit fuse)	slow 10/fast 20	A
Weight	approx. 0.5	kg

Solenoid:	Value	Unit
Solenoid operating voltage	24 V DC / 110 V AC / 230 V AC (for all - 15 % / + 10 %)	
On time	100	%
Power absorbed	8	W

Insertion depth (necessary minimum travel + permissible overtravel)	Standard Actuator	Overtravel Actuator	
Approach direction side (h)	28 + 2	28 + 7	mm
Approach direction from top (v)	29.5 + 1.5	-	mm

Pin assignment type i10 Lock...2

View from connection side

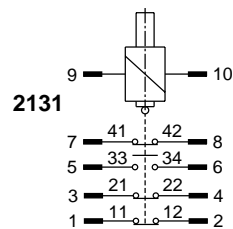
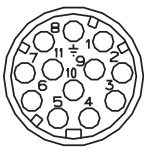

Ordering table i10 Lock

Safety Interlock with Locking

Type	Solenoid release		Solenoid Voltage		Connector		Part number
	mechanical	electrical	24 V DC	230 V AC	PG 13.5	SR 11	
i10-	M		024		1		6 012 135
i10-		E	024		1		6 012 136
i10-	M			230	1		6 012 137
i10-		E		230	1		6 012 138
i10-	M		024			2	6 012 139
i10-		E	024			2	6 012 140

Switching element: 1 NO/3 NC as standard. Other switching elements on request.

Low duty without solenoid release

Door interlocks with strong plastic housings and small dimensions.

Use

Highly versatile, ideal for small door openings.



Safety Interlocks

Series i10

Housing:	Reinforced thermoplastic
Connection:	Cable entry
Switching elements:	2 contacts



Explosive area zone 2

Dimensional drawing Type i10

Fixing to EN 50047

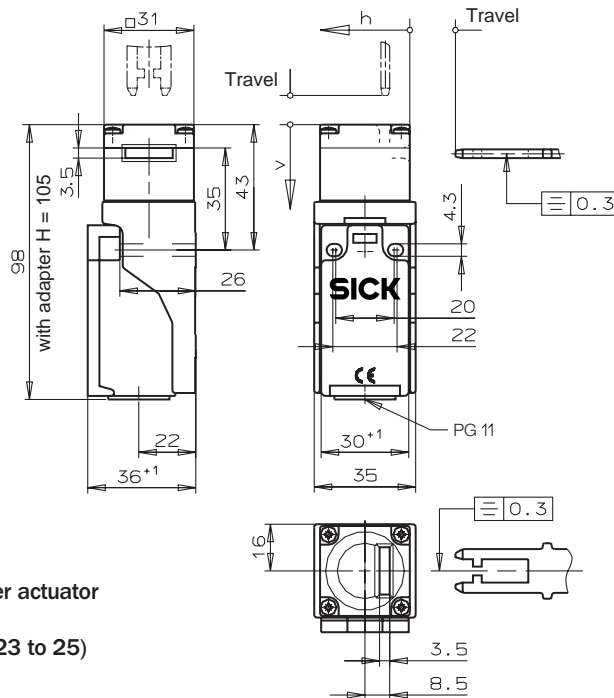

Please order actuator separately.
(See page 23 to 25)

Switching elements

528 Dependent action contact element, 1 positively driven NC + 1 NO contact

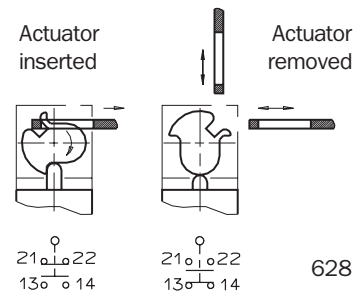

Installation notes

The safety interlock and actuator must be assembled for installation purposes. The actuator must be positively connected with the mounting surface, e.g. by using safety screws or by welding, riveting, pinning. The safety interlock must not be used as an end stop.

Changing the approach direction

The actuator head can be turned to the desired approach direction after undoing the fixing screws. Manufacturer setting is approach direction A.

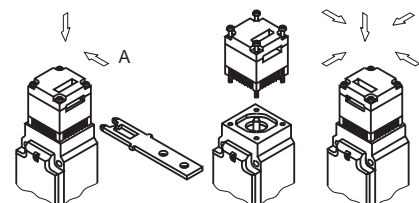

Technical data

Parameter	Value	Unit
Housing material	Reinforced thermoplastic	
Environmental protection IEC 529	IP 65 with PG 11	
Mounting position	optional	
Mechanical service life	10 ⁶ Switching cycles	
Ambient temperature	- 25 to + 80	°C
Approach speed max.	20	m/min
Switching element	628	
Contact elements	1 NC ⊖ + 1 NO	
Switching principle	Dependent action contact element	
Rated voltage	NP 1: U _i = 400	V≅
Utilization category to IEC 947-5-1	AC-15 U _e 230 V I _e 4 A / DC-13 U _e 24 V I _e 4 A	
Switching voltage min.	24	V
Switching current min. at 24 V	30	mA
Contact material	Silver alloy	
Connection type i10...1	Screw terminal, PG 11	
Wire cross-section max.	1.5	mm ²
Short-circuit protection (control circuit fuse)	slow 6 / fast 10	A
Weight	approx. 0.1	kg

Insertion depth ¹⁾	Standard Actuator	
Approach direction side (h)	28 + 2	mm
Approach direction from top (v)	29.5 + 1.5	mm

¹⁾ Necessary minimum travel and permissible overtravel

Technical data

Parameter	Value		Unit
Housing material	Reinforced thermoplastic		
Environmental protection to IEC 529	IP 67		
Mounting position	optional		
Mechanical service life	10 ⁶ switching cycles		
Ambient temperature	- 25 to + 80		°C
Approach speed max.	20		m/min
Switching element	...06...	...12...	
Contact elements	1 NC ⊖	2 NC ⊖ + 1 NO	
Switching principle	Dependent action contact element		
Rated voltage	U _i = 250		V ≅
Utilization category IEC 947-5-1	AC-15 U _e 230 V I _e 6 A / DC-13 U _e 24 V I _e 6 A		
Switching voltage min.	12		V
Switching current min. bei 24 V	10		mA
Contact material	Silver alloy, gold flashed		
Connection type	Screw terminal		
Cable entry	1 x PG 9	3 x PG 9	
Actuation force	approx. 6		N
Retaining force	approx. 10		N
Wire cross-section max.	1.5		mm ²
Short-circuit protection (control circuit fuse)	slow 10 / fast 20		A
Weight	approx. 0.08	approx. 0.1	kg

Insertion depth	Value	Unit
Necessary minimum travel	20	mm
Permissible overtravel	4	mm

Minimum door radius

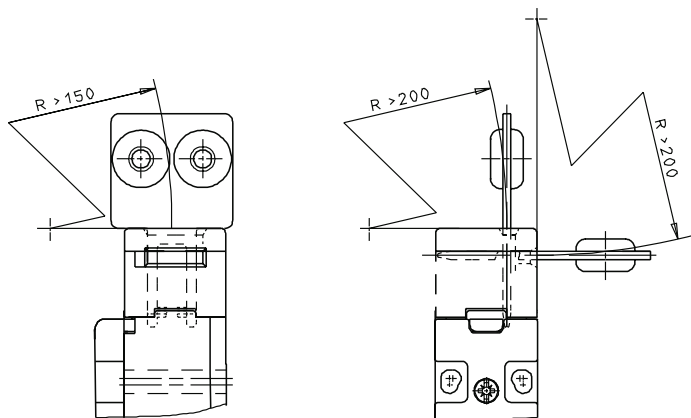

Ordering table i10

Safety Interlock

Type	Mounting EN 50 047	40 mm hole spacing	Dual Pole Switch			Connector		Part number
			1 NC	1 NC / 1 NO	2 NC	PG 13.5	SR 11	
i10-	A			07		1		6 012 134

Other versions: on request

Ordering table i11 mini

Safety Interlock

Type	Actuator Type	Dual Pole Switch		Connector PG 9	Part number
		1 NC	2 NC / 1 NO		
i11-	S		12	1	6 012 162
i11-	S	06		1	6 012 163

Connector type: on request

Low duty accessories

Accessories for SICK low duty series of Safety Interlocks.

Use

Can be used for any application when employed in combination with various approach directions.



Interlock accessories

Series i10 and i10 Lock Actuators

Straight actuator

Part No.: 5 306 527
 (2 safety screws included)
 Min. door radius 1000 mm

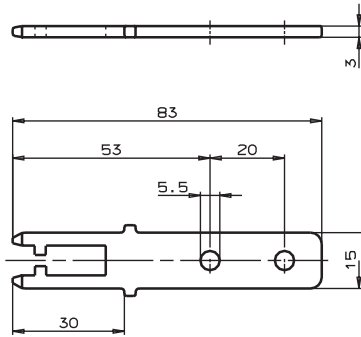

Bent actuator

Part No.: 5 306 535
 (2 safety screws included)
 Min. door radius 1000 mm

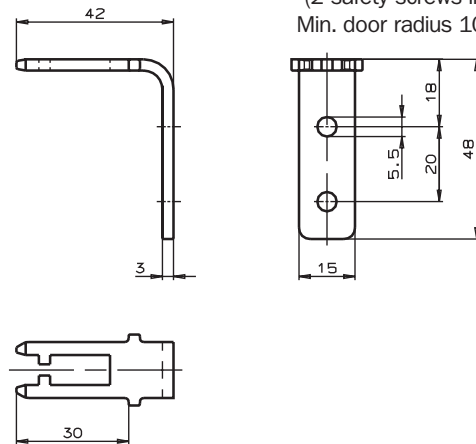

Straight actuator

for top and bottom hung doors

Part No.: 5 306 528
 (2 safety screws included)
 Min. door radius 90 mm

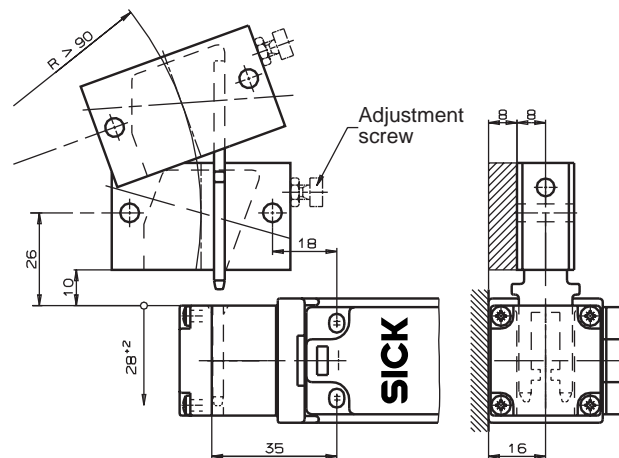
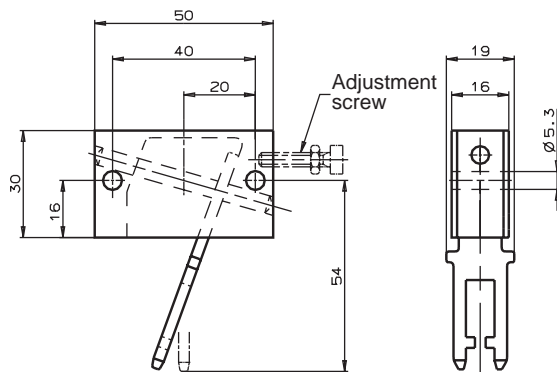

Straight actuator

for right and left hand hung doors

Part No.: 5 306 529
 (2 safety screws included)
 Min. door radius 100 mm

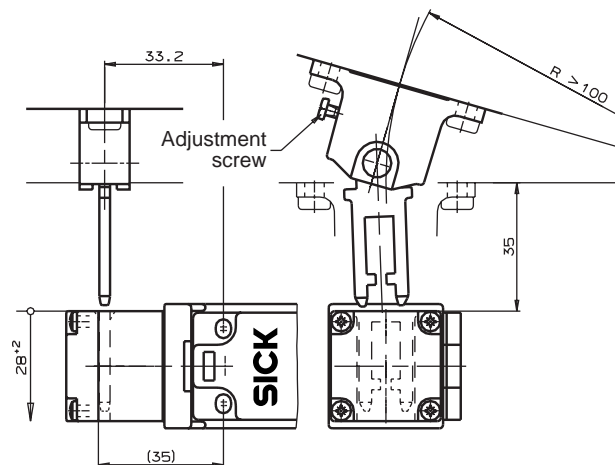
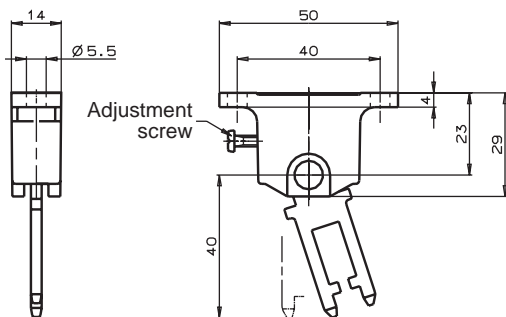

Straight actuator with rubberbush

Part No.: 5 306 530
 (2 safety screws included)
 Min. door radius 1000 mm

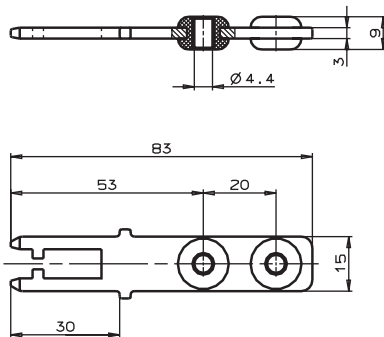

Lockout bar

Part No.: 5 306 536

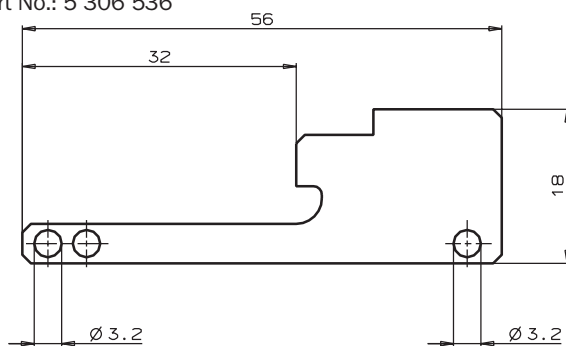

The locking bar can be inserted into the safety interlock in place of the actuator when the safety guard is in the open condition and can be secured to prevent its removal by standard commercially available padlocks (max. 2 pcs.). This guarantees reliable protection for persons who have to enter potentially hazardous areas.

Straight actuator

Part No. 5 306 537
(2 safety screws M 4 x 14 included)

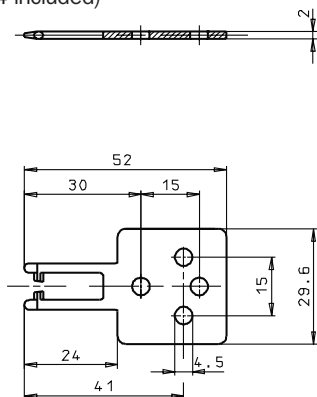

Bent actuator

Part No. 5 306 538
(2 safety screws M 4 x 14 included)

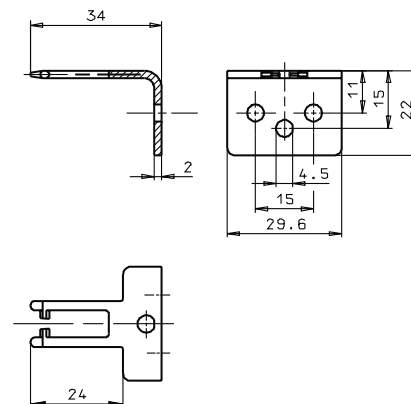

Straight actuator

rubberbush in longitudinal direction

Part No. 5 306 539
(2 safety screws M 4 x 14 included)

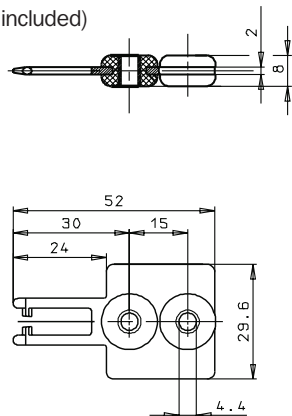

Straight actuator

rubberbush in longitudinal direction

Part No. 5 306 541
(2 safety screws M 4 x 14 included)

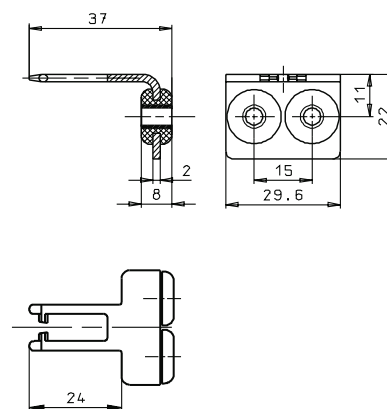

Straight actuator

rubberbush in cross direction

Part No. 5 306 540
(2 safety screws M 4 x 14 included)

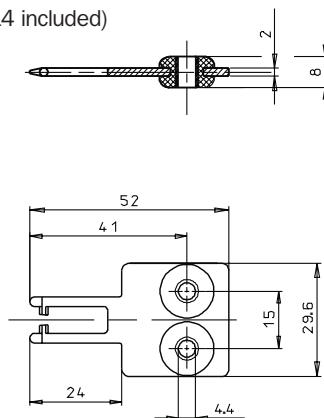

Ordering table iE 10

Key Actuator for i10 Lock and i10

Type	Actuator Type					Lockout Bar	Part number
	straight	straight with rubber	90° angled	Radius: door hinged			
				left side	right side		
iE 10-	S 1						5 306 527
iE 10-		S 2					5 306 530
iE 10-			A 1				5 306 535
iE 10-				R 1			5 306 528
iE 10-					R 2		5 306 529
iE 10-						S 3	5 306 536

Ordering table iE 11

Key Actuator for Safety Interlock i11 mini

Type	Actuator Type					Part number
	straight	straight with rubber		angled	angled with rubber	
		in line	transversal		transversal	
iE 11-	S 1					5 306 537
iE 11-		S 2				5 306 539
iE 11-			S 3			5 306 540
iE 11-				A 1		5 306 538
iE 11-					A 2	5 306 541

PG cable gland

Type	Part number
PG 9	5 305 547
PG 11	5 305 811

Heavy duty with solenoid release

Robust, highly reliable metal interlocks for frequent operation and extreme environmental conditions. For safeguarding machines with run-on conditions.

Use

Always required whenever the stop time of the machine is *greater* than the access time.



with monitored solenoid release

Housing:	Anodized die-cast light alloy
Actuator head:	Left
Connection:	Cable entry PG 13.5
Switching elements:	2 contacts

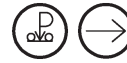

Dimensional drawing

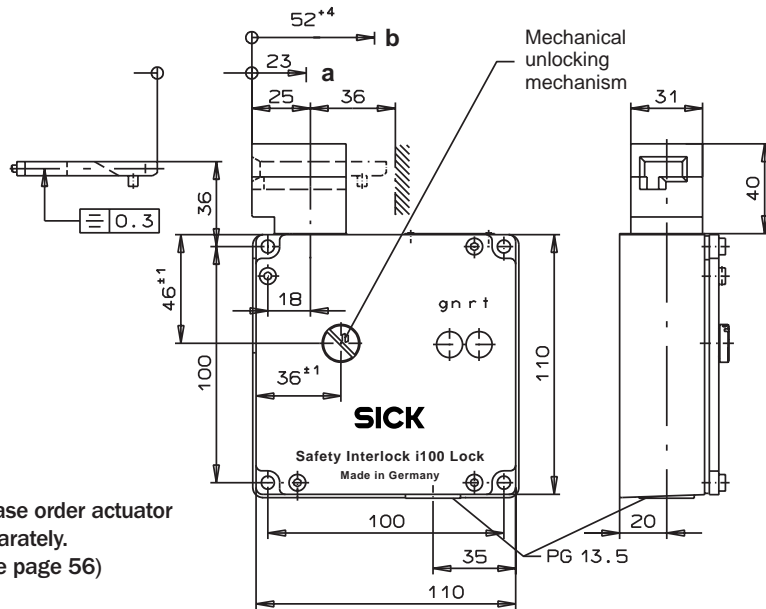

Please order actuator separately.
(See page 56)

a) Pre-travel:

The actuator is in the guide, but does not initiate switching operation.

b) Switching operation complete:

The actuator must be inserted up to this point to ensure reliable switching.
The actuator must be withdrawn at least to point a for switching off.

Switching elements

ES 528 Slow-action interlock
1 positively driven NC + 1 NO contact
(See page 100 for further details)

Locking methods

M: Actuator inserted, mechanically locked, unlocking by applying voltage.
E: Locking by applying voltage.

Solenoid operating voltages

24 V AC/DC – 15 % to + 10 %
110 V AC – 15 % to + 10 %
230 V AC – 15 % to + 10 %

LED function display

The function display makes it possible to check the respective operating state of the safety interlock.

Only Green: Safety circuit closed
Only Red: Key unlocked, safety circuit open.

The LED voltage corresponds to the solenoid operating voltage. Please specify other operating voltages in the safety and monitoring circuit.

Warning

The complete safety interlock must be replaced in the event of damage or wear.

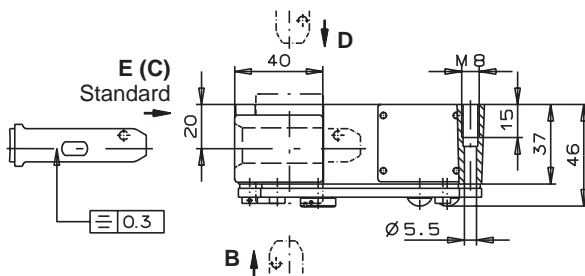

Installation notes

The safety interlock and actuator must be assembled for installation purposes. The actuator must be positively connected with the mounting surface, e.g. by using safety screws or by welding, riveting, pinning. The safety interlock must not be used as an end stop.
(See page 98 for further information)

Mechanical unlocking mechanism

Safety interlocks with mechanical locking can be unlocked by means of the mechanical unlocking mechanism in the event of power failure, for example. The mechanical unlocking mechanism can be sealed to prevent manipulation (lead seal set supplied).

Changing the approach direction

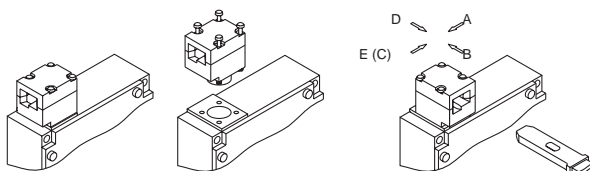

Changing the approach direction

The actuator head can be turned to the desired approach direction after undoing the fixing screws. The working illustration is as shown (approach direction E).

Technical data

Parameter	Value	Unit
Housing material	Anodized die-cast light alloy	
Color of housing cover	black	
Environmental protection IEC 529	IP 67	
Mounting position	optional	
Mechanical service life	2 x 10 ⁶ Switching cycles	
Ambient temperature	- 25 to + 80	°C
Approach speed max.	20	m/min
Actuating force	35	N
Retaining force in locked condition	1000	N
Switching element	2 x ES 528	
Contact elements	1 NO + 1 NC ⊖	
Switching principle	Slow-action	
Rated impulse withstand voltage U _{imp}	4.0	kV
Rated insulation voltage U _i	250	V ≅
Utilization category to IEC 947-5-1	AC-15 U _e 230 V I _e 6 A / DC-13 U _e 24 V I _e 6 A	
Switching voltage min.	12	V
Switching current min. at 24 V	10	mA
Contact material	Silver alloy, gold flashed	
Connection type	Screw terminal	
Cable cross section max.	1.5	mm ²
Short-circuit protection (control circuit fuse)	slow 10/ fast 20	A
Weight (incl. solenoid)	approx. 1.07	kg

Solenoid	Value	Unit
Solenoid operating voltage ¹⁾	24/110/230	V ≅
ON time	100	%
Connected load	7	W

¹⁾ Other operating voltages available to order

Switching diagram

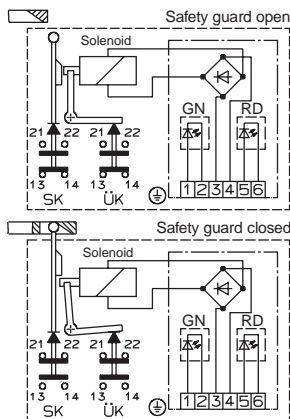

Circuit diagram (to be connected by the user)

Depicted:
Safety guard closed
Actuator locked

SK = Safety circuit
ÜK = Monitoring circuit

Terminal 1 to 6 of PCB
terminal strip are shown by ○.

Line 2: Safety guard open
Line 3: Safety guard closed and locked
Line 4: Safety guard to unlock
(e.g. release of Zero Speed Indicator)
Line 6: Unlocked (released for opening)

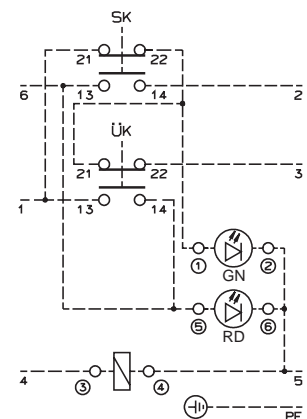

with monitored solenoid release

Housing:	Anodized die-cast light alloy
Actuator head:	Right
Connection:	Cable entry PG 13.5
Switching elements:	2 contacts



Dimensional drawing

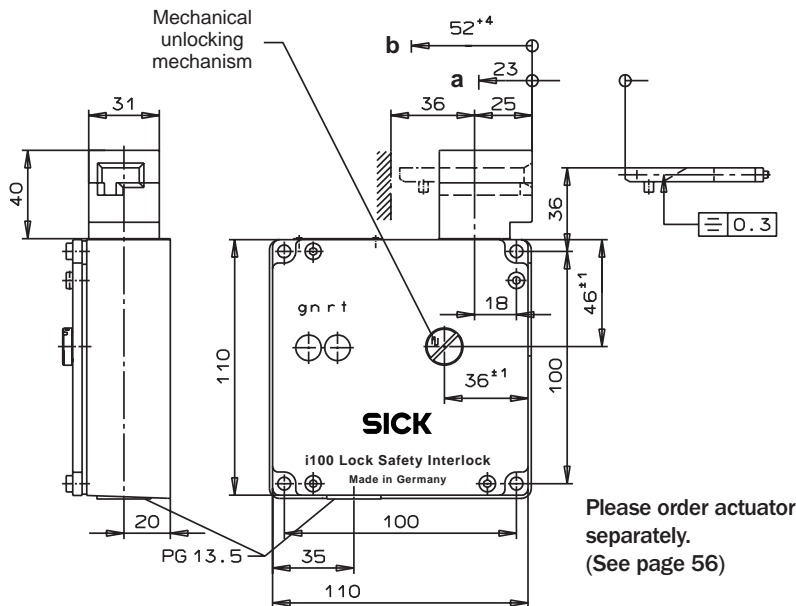

a) Pre-travel:
The actuator is in the guide, but does not initiate switching operation.

b) Switching operation complete:
The actuator must be inserted up to this point to ensure reliable switching.
The actuator must be withdrawn at least to point a for switching off.

Switching elements

ES 528 Slow-action interlock
1 positively driven NC + 1 NO contact
(See page 100 for further details)

Locking methods

M: Actuator inserted, mechanically locked, unlocking by applying voltage.
E: Locking by applying voltage.

Solenoid operating voltages

24 V AC/DC – 15 % to + 10 %
110 V AC – 15 % to + 10 %
230 V AC – 15 % to + 10 %

LED function display

The function display makes it possible to check the respective operating state of the safety interlock.

Only Green: Safety circuit closed
Only Red: Key unlocked, safety circuit open.

The LED voltage corresponds to the solenoid operating voltage. Please specify other operating voltages in the safety and monitoring circuit.

Warning

The complete safety interlock must be replaced in the event of damage or wear.

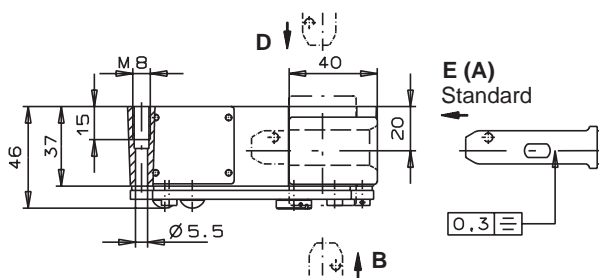

Installation notes

The safety interlock and actuator must be assembled for installation purposes. The actuator must be positively connected with the mounting surface, e.g. by using safety screws or by welding, riveting, pinning. The safety interlock must not be used as an end stop.
(See page 98 for further information)

Mechanical unlocking mechanism

Safety interlocks with mechanical locking can be unlocked by means of the mechanical unlocking mechanism in the event of power failure, for example. The mechanical unlocking mechanism can be sealed to prevent manipulation (lead seal set supplied).

Changing the approach direction

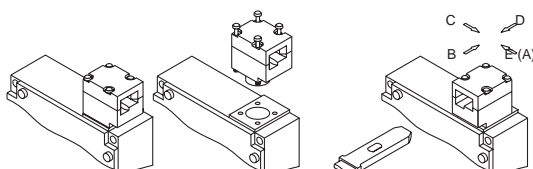

Changing the approach direction

The actuator head can be turned to the desired approach direction after undoing the fixing screws. The working illustration is as shown (Approach direction E).

Technical data

Parameter	Value	Unit
Housing material	Anodized die-cast light alloy	
Color of housing cover	black	
Environmental protection IEC 529	IP 67	
Mounting position	optional	
Mechanical service life	2 x 10 ⁶ Switching cycles	
Ambient temperature	- 25 to + 80	°C
Approach speed max.	20	m/min
Actuating force	35	N
Retaining force in locked condition	1000	N
Switching element	2 x ES 528	
Contact elements	1 NO + 1 NC ⊖ each	
Switching principle	Slow-action	
Rated impulse withstand voltage U _{imp}	4.0	kV
Rated insulation voltage U _i	250	V ≅
Utilization category to IEC 947-5-1	AC-15 U _e 230 V I _e 6 A / DC-13 U _e 24 V I _e 6 A	
Switching voltage min.	12	V
Switching current min. at 24 V	10	mA
Contact material	Silver alloy, gold flashed	
Connection type	Screw terminal	
Cable cross section max.	1.5	mm ²
Short circuit protection (control circuit fuse)	slow 10 / fast 20	A
Weight (incl. solenoid)	approx. 1.07	kg

Solenoid	Value	Unit
Solenoid operating voltage ¹⁾	24 / 110 / 230	V ≅
ON time	100	%
Connected load	7	W

¹⁾ Other operating voltages available to order

Switching diagram

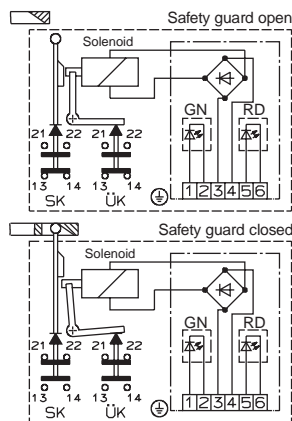

Circuit diagram (to be connected by the user)

Depicted:
Safety guard closed
Actuator locked

SK = Safety circuit
ÜK = Monitoring circuit

Terminal 1 to 6 of PCB terminal strip are shown by ○.

Line 2: Safety guard open
Line 3: Safety guard closed and locked
Line 4: Safety guard to unlock
(e.g. release of Zero Speed Indicator)
Line 6: Unlocked (released for opening)

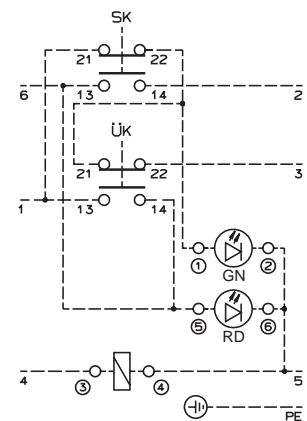

with monitored solenoid release

Housing:	Anodized die-cast light alloy
Actuator head:	Left
Connection:	Plug connector SR 11 (see page 58)
Switching elements:	2 contacts



Dimensional drawing

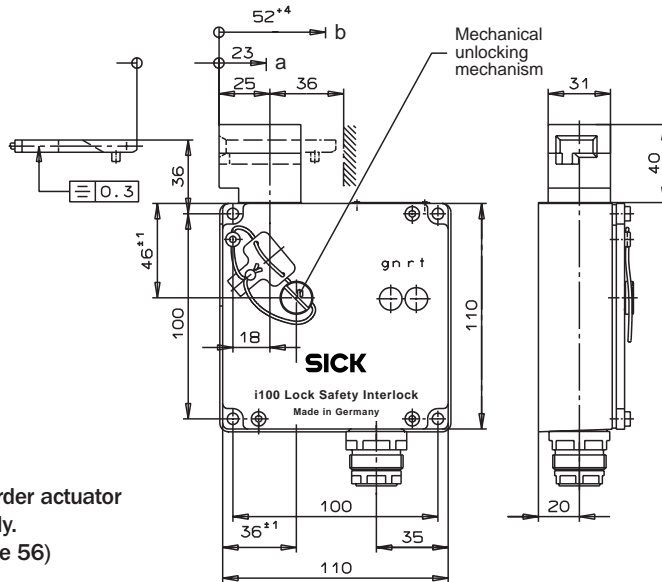

Please order actuator separately.
(See page 56)

a) Pre-travel:

The actuator is in the guide, but does not initiate switching operation.

b) Switching operation complete:

The actuator must be inserted up to this point to ensure reliable switching.
The actuator must be withdrawn at least to point a for switching off.

Warning

The complete safety interlock must be replaced in the event of damage or wear.

Dimensions plug connector connection SR 11

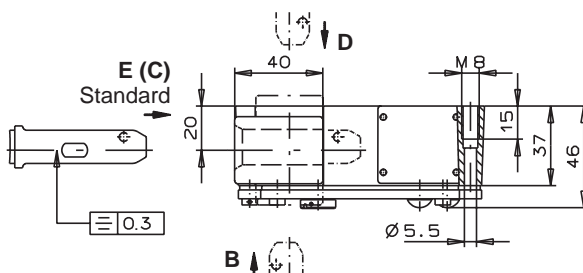
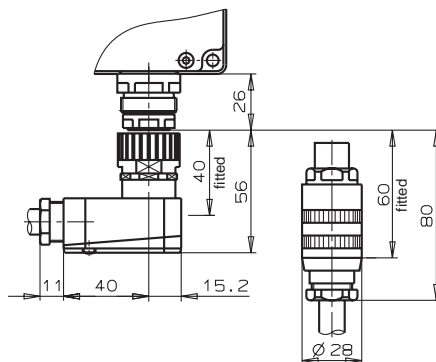

Switching elements

ES 528 Slow-action interlock
1 positively driven NC + 1 NO contact
(See page 100 for further details)

Locking methods

M: Actuator inserted, mechanically locked, unlocking by applying voltage.
E: Locking by applying voltage.

Solenoid operating voltages

24 V AC/DC – 15 % to + 10 %

LED function display

The function display makes it possible to check the respective operating state of the safety interlock.

Only Green: dependent on wiring:
Power on / actuator unlocked
Only Red: customer specific

The LED voltage corresponds to the solenoid operating voltage. Please specify other operating voltages in the safety and monitoring circuit.

Installation notes

The safety interlock and actuator must be assembled for installation purposes. The actuator must be positively connected with the mounting surface, e.g. by using safety screws or by welding, riveting, pinning. The safety interlock must not be used as an end stop.
(See page 98 for further information)

Mechanical unlocking mechanism

Safety interlocks with mechanical locking can be unlocked by means of the mechanical unlocking mechanism in the event of power failure, for example. The mechanical unlocking mechanism can be sealed to prevent manipulation (lead seal set supplied).

Changing the approach direction

The actuator head can be turned to the desired approach direction after undoing the fixing screws. The working illustration is as shown (Approach direction E).

Technical data

Parameter	Value	Unit
Housing material	Anodized die-cast light alloy	
Color of housing cover	black	
Environmental protection IEC 529	IP 65	
Mounting position	optional	
Mechanical service life	2 x 10 ⁶ Switching cycles	
Ambient temperature	- 25 to + 80	°C
Approach speed max.	20	m/min
Actuating force	35	N
Retaining force in locked condition	1000	N
Switching element	2 x ES 528	
Contact elements	1 NO + 1 NC ⊖	
Switching principle	Slow-action	
Rated impulse withstand voltage U _{imp}	4.0	
Rated insulation voltage U _i	50	V ≅
Utilization category to IEC 947-5-1	AC-15 U _e 50 V I _e 6 A / DC-13 U _e 24 V I _e 6 A	
Switching voltage min.	12	V
Switching current min. at 24 V	10	mA
Contact material	Silver alloy, gold flashed	
Connection type	Plug connector 11 + PE (DIN 43651)	
Short-circuit protection (control circuit fuse)	slow 10/fast 20	A
Weight (incl. solenoid)	approx. 1.14	kg

Solenoid	Value	Unit
Solenoid operating voltage ¹⁾	24/110/230	V ≅
ON time	100	%
Connected load	7	W

¹⁾ Other operating voltages available to order

Switching diagram

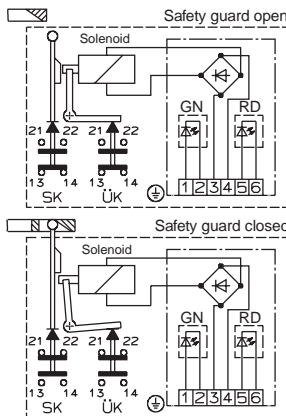

Circuit diagram (internally wired)

Depicted:
Safety guard closed
Actuator locked

SK = Safety circuit
ÜK = Monitoring circuit

Terminal 1 to 6 of PCB
terminal strip are shown by ○.

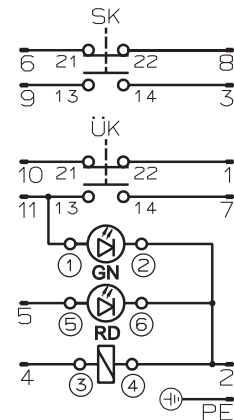

with monitored solenoid release

Housing:	Anodized die-cast light alloy
Actuator head:	Right
Connection:	Plug connector SR 11 (see page 58)
Switching elements:	2 contacts



Dimensional drawing

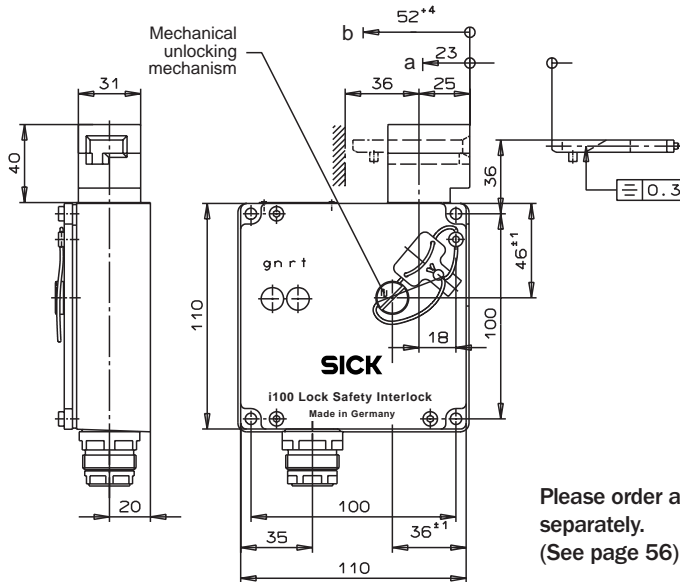

a) Pre-travel:

The actuator is in the guide, but does not initiate switching operation.

b) Switching operation complete:

The actuator must be inserted up to this point to ensure reliable switching.
The actuator must be withdrawn at least to point a for switching off.

Warning

The complete safety interlock must be replaced in the event of damage or wear.

Dimensions plug connector connection SR 11

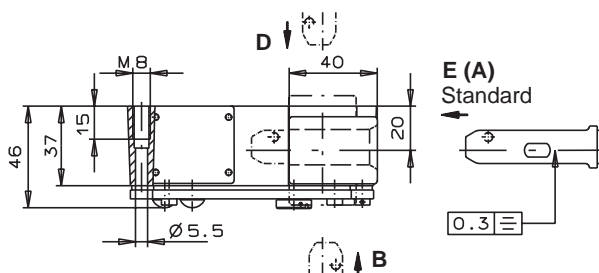
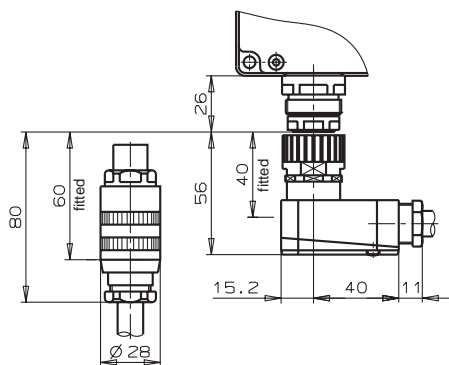

Switching elements

ES 528 Slow-action interlock
1 positively driven NC + 1 NO contact
(See page 100 for further details)

Locking methods

M: Actuator inserted, mechanically locked, unlocking by applying voltage.
E: Locking by applying voltage.

Solenoid operating voltages

24 V AC/DC – 15 % to + 10 %

LED function display

The function display makes it possible to check the respective operating state of the safety switch.

Only Green: dependent on wiring:
Power on / actuator unlocked

Only Red: customer specific

The LED voltage corresponds to the solenoid operating voltage. Please specify other operating voltages in the safety and monitoring circuit.

Installation notes

The safety interlock and actuator must be assembled for installation purposes. The actuator must be positively connected with the mounting surface, e.g. by using safety screws or by welding, riveting, pinning. The safety interlock must not be used as an end stop.
(See page 98 for further information)

Mechanical unlocking mechanism

Safety interlocks with mechanical locking can be unlocked by means of the mechanical unlocking mechanism in the event of power failure, for example. The mechanical unlocking mechanism can be sealed to prevent manipulation (lead seal set supplied).

Changing the approach direction

The actuator head can be turned to the desired approach direction after undoing the fixing screws. The working illustration is as shown (Approach direction E).

Technical data

Parameter	Value	Unit
Housing material	Anodized die-cast light alloy	
Color of housing cover	black	
Environmental protection IEC 529	IP 65	
Mounting position	optional	
Mechanical service life	2 x 10 ⁶ Switching cycles	
Ambient temperature	- 25 to + 80	°C
Approach speed max.	20	m/min
Actuating force	35	N
Retaining force in locked condition	1000	N
Switching element	2 x ES 528	
Contact elements	1 NO + 1 NC ⊖	
Switching principle	Slow-action	
Rated impulse withstand voltage U _{imp}	4.0	kV
Rated insulation voltage U _i	50	V ≅
Utilization category to IEC 947-5-1	AC-15 U _e 50 V I _e 6 A/DC-13 U _e 24 V I _e 6 A	
Switching voltage min.	12	V
Switching current min. at 24 V	10	mA
Contact material	Silver alloy, gold flashed	
Connection type	Plug connector 11 + PE (DIN 43651)	
Short-circuit protection (control circuit fuse)	slow 10/fast 20	A
Weight (incl. solenoid)	approx. 1.14	kg

Solenoid	Value	Unit
Solenoid operating voltage ¹⁾	24	V ≅
ON time	100	%
Connected load	7	W

¹⁾ Other operating voltages available to order

Switching diagram

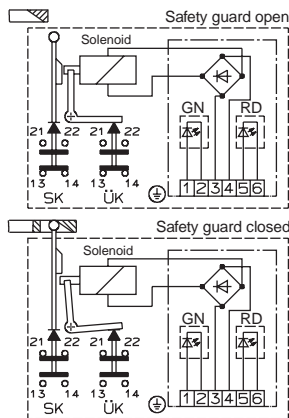

Circuit diagram (internally wired)

Depicted:
 Safety guard closed
 Actuator locked

SK = Safety circuit
 ÜK = Monitoring circuit

Terminal 1 to 6 of PCB terminal strip are shown by ○.

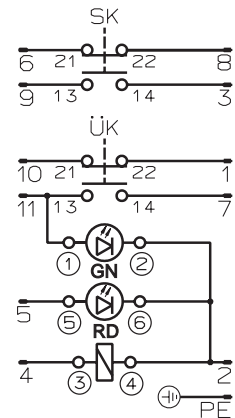

Ordering table

Safety Interlocks with solenoid release

Type	Locking		Actuating Head		Solenoid Voltage		Connector		Part number
	mechanical	electrical	right	left	24 V DC	230 V AC	PG 13.5	SR 11	
i100-	M		R		024		1		6 012 121
i100-		E	R		024		1		6 012 122
i100-	M			L	024		1		6 012 117
i100-		E		L	024		1		6 012 118
i100-	M		R			230	1		6 012 123
i100-		E	R			230	1		6 012 124
i100-	M			L		230	1		6 012 119
i100-		E		L		230	1		6 012 120
i100-	M		R		024			2	6 012 127
i100-		E	R		024			2	6 012 125
i100-	M			L	024			2	6 012 128
i100-		E		L	024			2	6 012 126

Heavy duty without solenoid release

Robust, highly reliable metal interlock for frequent operation and extreme environmental conditions. A large variety of construction designs to suit all applications.

Use

Used whenever the access time is *greater* than the machine's stop time.



Design – Function – Details

Applications

The safety interlocks in this series are used for protection of personnel, machines and production goods throughout the whole field of mechanical and plant engineering thanks to their design concept and high degree of flexibility.

A fully-developed design, the use of top quality materials and SICK-production know-how guarantee problem-free operation of these devices under even the most stringent conditions.

Two different types are available :

Position switches

In accordance with EN 50041 with safety function
Type series i100

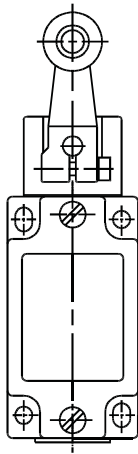

Design

The safety interlocks of this series possess an anodized die-cast light alloy housing. They are characterized by a high level of operating reliability, high strength and corrosion resistance.

Reliability and function are assured over and beyond the guaranteed service life by the use of top quality materials for the plungers, drive mechanisms and seals.

Function

This series is characterized by positive interaction of all actuating elements in the functional sequence of the interlocks. This guarantees that the switching element responsible for the safety function positively disconnects circuits even in the event of contact welding, for example.

Flexibility

These safety interlocks are universal components for the whole field of mechanical and plant engineering thanks to the many conversion possibilities :

- approach directions (4 x 90°)
- actuator directions (4 x 90°) for roller-lever mechanism
- switching directions left/right/two-way.

Refer to the adjacent page for further information.

LED display

Safety interlocks can be equipped with a function display (LED) if required. This is available for the voltage ranges

12–60 V		AC/DC
110 V	± 15 %	AC
230 V	± 15 %	AC

A built-in electronic controller guarantees constantly high luminosity independently of the applied voltage.

Actuator and approach direction

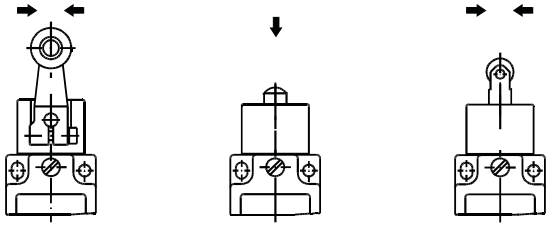

R = Roller lever steel
 D = Dome plunger
 P = Roller plunger

Plunger Rotation – Actuator

Horizontal repositioning 4 x 90°

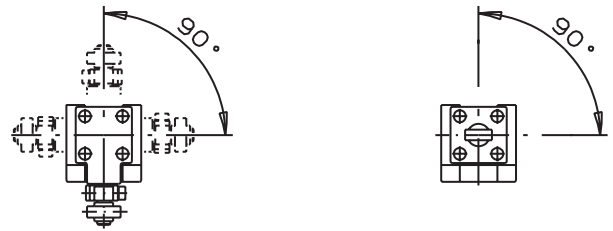

Roller lever

Straight actuator

Vertical conversion 4 x 90° (form fitted)

or infinitely adjustable through 360° (no positive fixing)

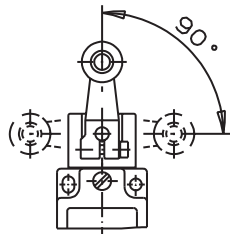

Convertible – switching direction

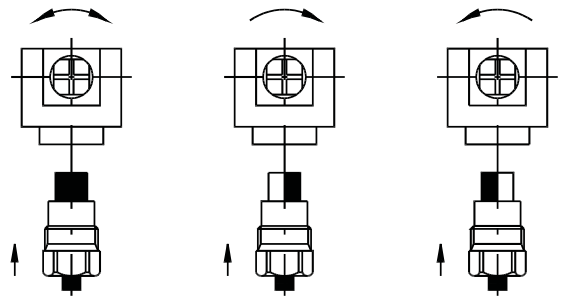

left/right switching
 (standard setting)

right-hand switching

left-hand switching



Safety Interlocks

Series i100 R 1 (cable entry)

Type:	Basic housing EN 50041
Housing:	Anodized die-cast light alloy
Connection:	Cable entry PG 13.5
Actuator:	Roller lever (Steel)
Switching elements:	4 contacts

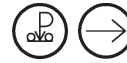

Dimensional drawing

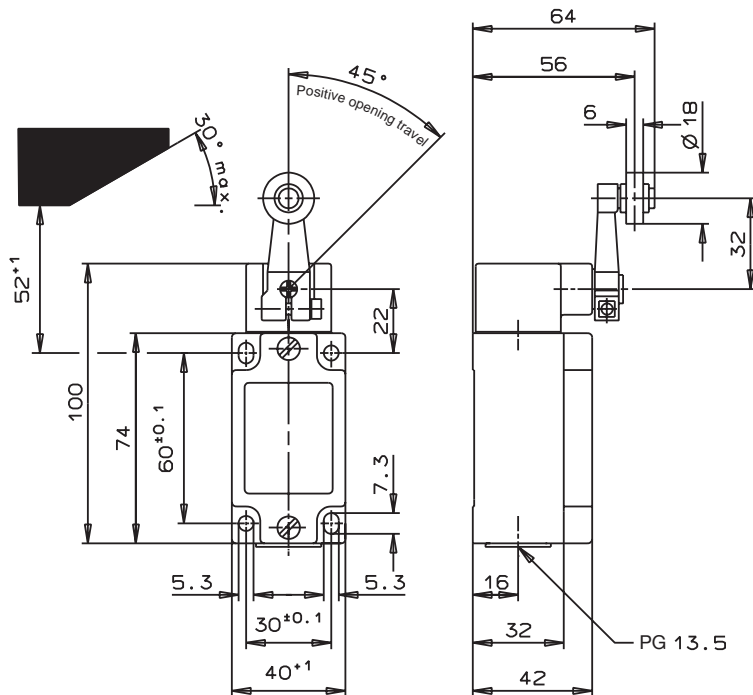

Switching elements

SK 2131 Slow-action switch
3 positively driven NC + 1 NO contact
(See page 101 for further details)

Installation notes

The radial cam distance shown in the dimensional drawing must be observed in order to obtain the correct air gap. Actuator elements such as the radial cam approach guide must be mounted on the interlock in accordance with VDI 2854, i.e. riveted, welded, or otherwise secured to prevent detachment.

Conversion possibilities

Horizontal and vertical 4 x 90°.
Switching direction: right hand, left hand or left/right switching.
(See page 102 for further details)

Warning

The complete safety interlock should be replaced in the event of damage or wear.

Actuator travel diagrams

Contacts
 open
 closed

SK 2131

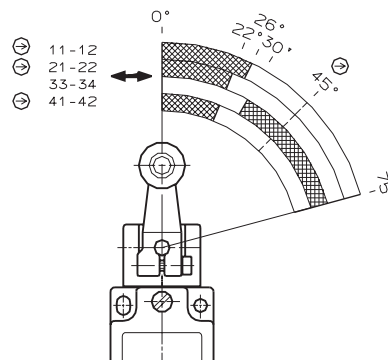

Technical data

Parameter	Value	Unit
Housing material	Anodized die-cast light alloy	
Environmental protection to IEC 529	IP 67	
Mounting position	optional	
Mechanical service life	30 x 10 ⁶ Switching cycles	
Ambient temperature	- 25 to + 80	°C
Actuator	Steel Roller lever	
Approach speed max. ¹⁾	60	m/min
Approach speed min.	0.1	m/min
Pretravel up to switching point	see actuator travel diagram	
Travel to isolating distance	45	°
Actuating force	10	N
Switching element	SK 2131	
Contact elements	3 NC ⊖ + 1 NO	
Switching principle	Slow-action	
Rated impulse withstand voltage U _{imp}	4.0	kV
Closing time	< 4	ms
Bounce time	< 3	ms
Rated insulation voltage U _i	250	V≅
Utilization category to IEC 947-5-1	AC-15 U _e 230 V I _e 6 A/DC-13 U _e 24 V I _e 6 A	
Switching voltage min.	12	V
Switching current min. at 24 V	10	mA
Contact material	Silver alloy, gold flashed	
Connection type	Screw terminal	
Cablecross-section max.	2 x 1.5	mm ²
Short-circuit protection (control circuit fuse)	slow 10/20 fast	A
Weight	approx. 0.3	kg

¹⁾ The approach speed is valid for a trip dog approach angle of 30°; it may be exceeded if the approach angle is reduced.

Connection diagram

Switching element SK 2131

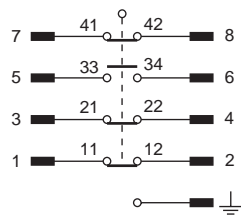

Safety Interlocks

Series i100 R 2 (plug connector)

Type:	Basic housing EN 50041
Housing:	Anodized die-cast light alloy
Connection:	Plug connector SR 11 (see page 58)
Actuator:	Roller lever (Steel)
Switching elements:	4 contacts



Dimensional drawing

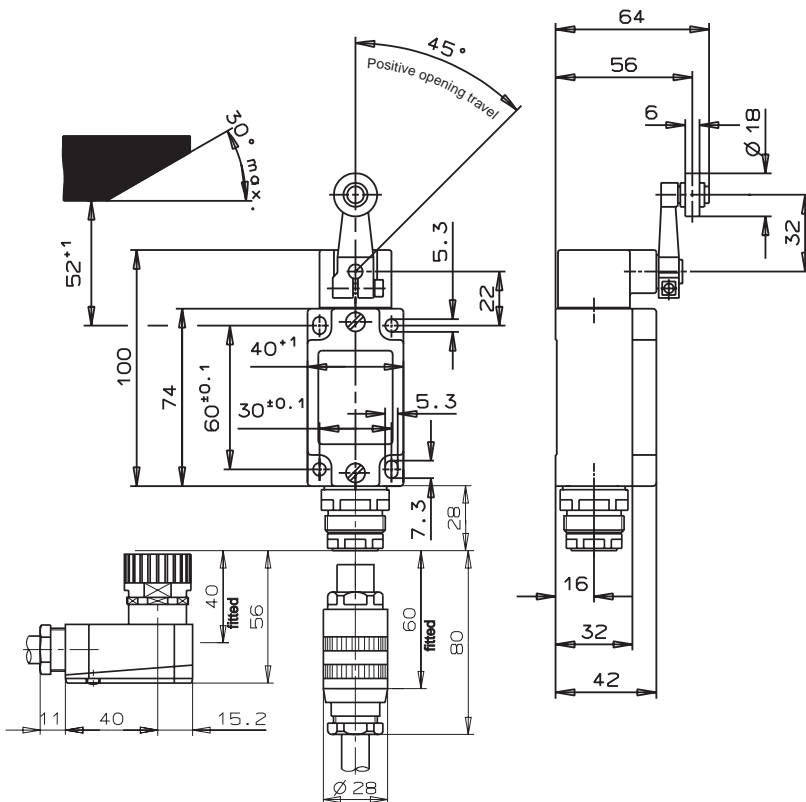

Switching elements

SK 2131 Slow-action interlock
3 positively driven NC + 1 NO contact
(See page 101 for further details)

Installation notes

The trip dog distance as shown in the dimension diagram must be observed in order to obtain the isolating distance. Actuating elements such as trip dogs must be installed with a positive connection in accordance with VDI 2854, e.g. riveted, welded or otherwise secured to prevent detachment.

Conversion possibilities

Horizontal and vertical 4 x 90°.
Switching direction: right hand, left hand or left/right switching.
(See page 102 for further details)

Warning

The complete safety interlock should be replaced in the event of damage or wear.

Actuator travel diagrams

Contacts
 open
 closed

SK 2131

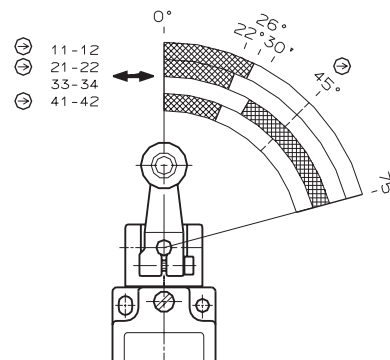

Technical data

Parameter	Value	Unit
Housing material	Anodized die-cast light alloy	
Environmental protection to IEC 529	IP 65	
Mounting position	optional	
Mechanical service life	30 x 10 ⁶ Switching cycles	
Ambient temperature	- 25 to + 80	°C
Actuator	Steel	
Roller material	Steel	
Approach speed max. ¹⁾	60	m/min
Approach speed min.	0.1	m/min
Pretravel up to switching point	see actuator travel diagram	
Travel to isolating distance	45	°
Actuating force	10	N
Switching element	SK 2131	
Contact elements	3 NC ⊖ + 1 NO	
Switching principle	Slow-action	
Rated impulse withstand voltage U _{imp}	4.0	kV
Closing time	< 4	ms
Bounce time	< 3	ms
Rated insulation voltage U _i	50	V≅
Utilization category to IEC 947-5-1	AC-15 U _e 50 V I _e 6 A/DC-13 U _e 24 V I _e 6 A	
Switching voltage min.	12	V
Switching current min. at 24 V	10	mA
Contact material	Silver alloy, gold flashed	
Connection type	Plug Connector 11 + PE (DIN 43651)	
Short-circuit protection (control circuit fuse)	slow 10/20 fast	A
Weight	approx. 0.35	kg

¹⁾ The approach speed is valid for a trip dog approach angle of 30°; it may be exceeded if the approach angle is reduced.

Connection diagram

Switching element SK 2131

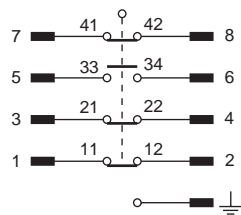

Safety Interlocks

Series i100 P 1 (cable entry)

Type:	Basic housing EN 50041
Housing:	Anodized die-cast light alloy
Connection:	Cable entry PG 13.5
Actuator:	RS (plunger with large steel roller)
Switching elements:	4 contacts



Dimensional drawing

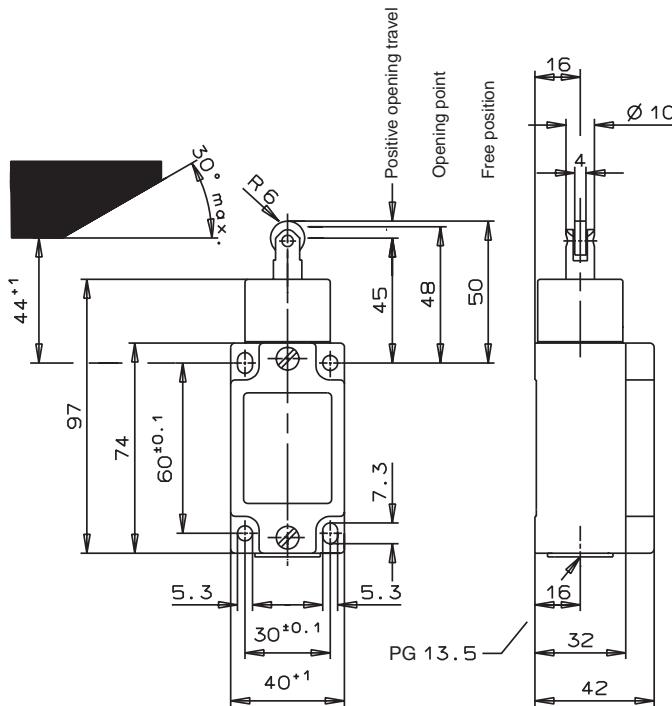

Switching elements

SK 2131 slow action interlock
3 captive NC contacts + 1 NO contact
(see page 101 for further details).

Installation notes

The trip dog distance as shown in the dimension diagram must be observed in order to obtain the isolating distance. Actuating elements such as trip dogs must be installed with a positive connection in accordance with VDI 2854, e.g. riveted, welded or otherwise secured to prevent detachment.

Conversion possibilities

Horizontal 4 x 90°.
(See page 102 for further details)

Warning

The complete safety interlock should be replaced in the event of damage or wear.

Plunger types / Actuator travel

Contacts

- open
- closed

RS = Steel roller
Form C (EN 50041)

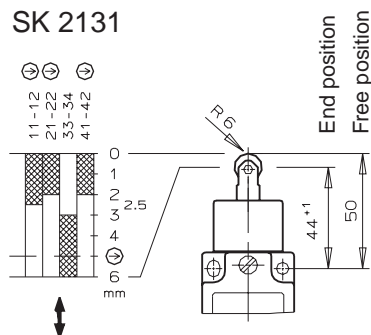

Technical data

Parameter	Value	Unit
Housing material	Anodized die-cast light alloy	
Environmental protection to IEC 529	IP 67	
Mounting position	optional	
Mechanical service life	30 x 10 ⁶ Switching cycles	
Ambient temperature	- 25 to + 80	°C
Plunger design	Maintenance-free	
Plunger type	RS	
Design to EN 50041-type	C 1	
Approach speed max.	20	m/min
Approach speed min.	0.01	m/min
Pretravel up to switching point	see actuator travel diagram	
Forced opening after switching point	≥ 0.8	mm
Actuating force	15	N
Switching element	SK 2131	
Contact elements	3 NC ⊖ + 1 NO	
Switching principle	Slow-action	
Rated impulse withstand voltage U _{imp}	4.0	kV
Closing time	< 4	ms
Bounce time	< 3	ms
Rated insulation voltage U _i	250	V _≅
Utilization category to IEC 947-5-1	AC-15 U _e 230 V I _e 6 A / DC-13 U _e 24 V I _e 6 A	
Switching voltage min.	12	V
Switching current min. at 24 V	10	mA
Contact material	Silver alloy, gold flashed	
Connection type	Screw terminal	
Cablecross-section max.	2 x 1.5	mm ²
Short-circuit protection (control circuit fuse)	slow 10/20 fast	A
Weight	approx. 0.3	kg

Connection diagram

Switching element SK 2131

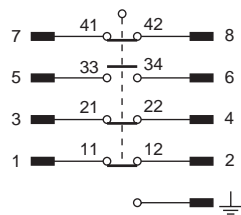

Safety Interlocks

Series i100 P 2 (plug connector)

Type:	Basic housing EN 50041
Housing:	Anodized die-cast light alloy
Connection:	Plug connector SR 11 (see page 58)
Actuator:	Plunger with large steel roller
Switching elements:	2 contacts



Dimensional drawing

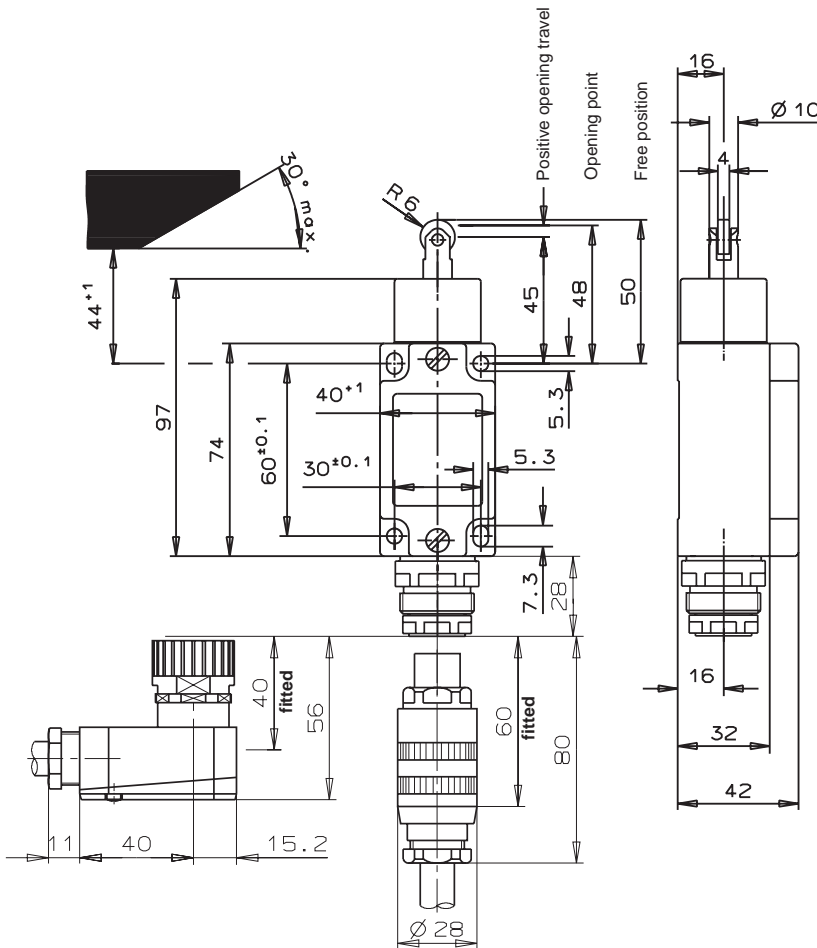

Switching elements

SK 2131 Slow-action switch
3 positively driven NC + 1 NO contact
(See page 101 for further details)

Installation notes

The trip dog distance as shown in the dimension diagram must be observed in order to obtain the isolating distance. Actuating elements such as trip dogs must be installed with a positive connection in accordance with VDI 2854, e.g. riveted, welded or otherwise secured to prevent detachment.

Conversion possibilities

Horizontal 4 x 90°.
(See page 102 for further details)

Warning

The complete safety interlock should be replaced in the event of damage or wear.

Plunger types / Actuator travel

Contacts

- open
- closed

Steel roller
Form C (EN 50041)

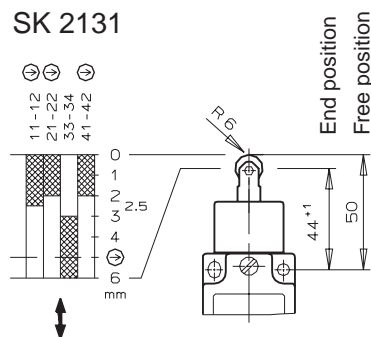

Technical data

Parameter	Value	Unit
Housing material	Anodized die-cast light alloy	
Environmental protection to IEC 529	IP 67	
Mounting position	optional	
Mechanical service life	30 x 10 ⁶ Switching cycles	
Ambient temperature	- 25 to + 80	°C
Plunger design	Maintenance-free	
Plunger type	Steel Roller	
Design to EN 50041-type	C 1	
Approach speed max.	20	m/min
Approach speed min.	0.01	m/min
Pretravel up to switching point	2	mm
Forced opening after switching point	≥ 0.8	mm
Actuating force	15	N
Switching element	SK 2131	
Contact elements	3 NC ⊖ + 1 NO	
Switching principle	Slow-action	
Rated impulse withstand voltage U _{imp}	4.0	kV
Closing time	< 4	ms
Bounce time	< 3	ms
Rated insulation voltage U _i	50	V _≅
Utilization category to IEC 947-5-1	AC-15 U _e 50 V I _e 6 A / DC-13 U _e 24 V I _e 6 A	
Switching voltage min.	12	V
Switching current min. at 24 V	10	mA
Contact material	Silver alloy, gold flashed	
Connection type	Plug connector 11 + PE (DIN 43651)	
Short-circuit protection (control circuit fuse)	slow 10/20 fast	A
Weight	approx. 0.35	kg

Connection diagram

Switching element SK 2131

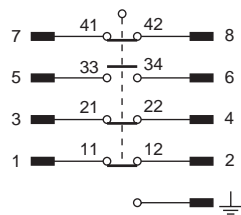

Safety Interlocks

Series i100 S 1 (cable entry)

Type:	Basic housing EN 50041
Housing:	Anodized die-cast light alloy
Connection:	Cable entry PG 13.5
Switching elements:	4 contacts



Dimensional drawing

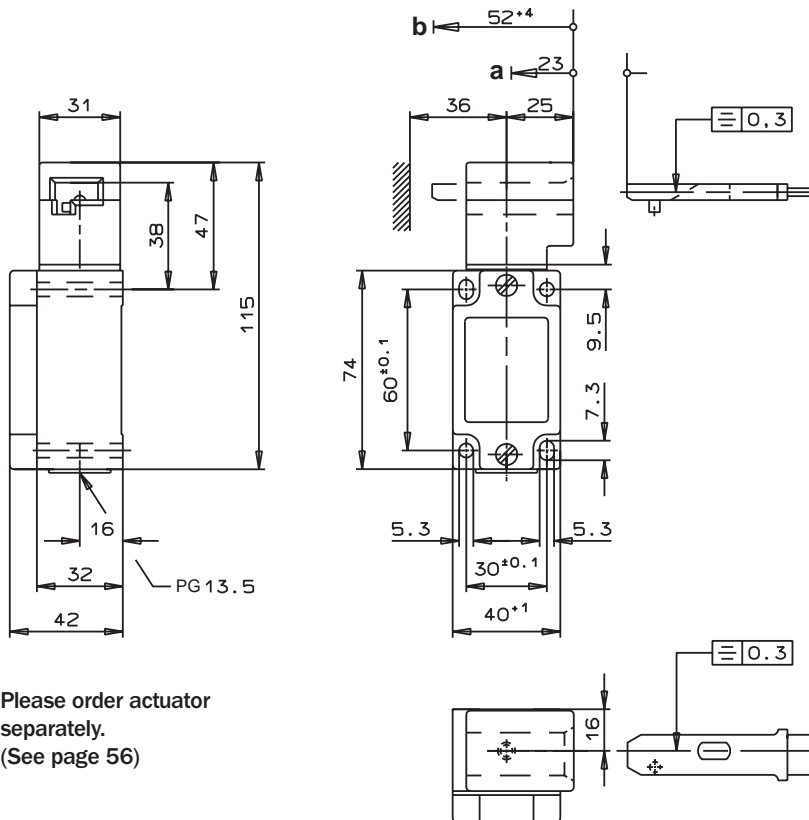

Please order actuator separately.
(See page 56)

a) Pre-travel:

The actuator is in the guide, but does not initiate switching operation.

b) Switching operation complete:

The actuator must be inserted up to this point to ensure reliable switching.

The actuator must be withdrawn at least to point a for switching off.

Switching elements

SK 2131 Slow-action interlock
3 positively driven NC + 1 NO contact
(See page 101 for further details)

Installation notes

The safety interlock and actuator must be assembled for installation purposes. The actuator must be positively connected with the mounting surface, e.g. by using safety screws or by welding, riveting, pinning. The safety interlock must not be used as an end stop.

Changing the approach direction

The actuator head can be turned to the desired approach direction after undoing the fixing screws. The working illustration is as shown (approach direction E).

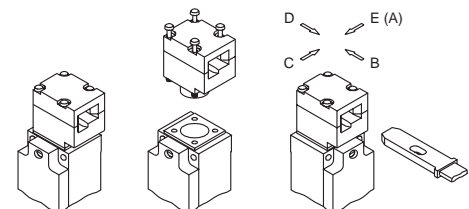

Warning

The complete safety interlock should be replaced in the event of damage or wear.

Technical data

Parameter	Value	Unit
Housing material	Anodized die-cast light alloy	
Environmental protection to IEC 529	IP 67	
Mounting position	optional	
Mechanical service life	2 x 10 ⁶ Switching cycles	
Ambient temperature	- 25 to + 80	°C
Approach speed max.	20	m/min
Actuating force	35	N
Switching element	SK 2131	
Contact elements	3 NC ⊖ + 1 NO	
Switching principle	Slow-action	
Rated impulse withstand voltage U _{imp}	4.0	kV
Rated insulation voltage U _i	250	V ≅
Utilisation category acc. to IEC 947-5-1	AC-15 U _e 230 V I _e 6 A / DC-13 U _e 24 V I _e 6 A	
Switching voltage min.	12	V
Switching current min. at 24 V	10	mA
Contact material	Silver alloy, gold flashed	
Connection type	Screw terminal	
Cablecross-section max.	1.5	mm ²
Short-circuit protection (control circuit fuse)	slow 10/20 fast	A
Weight	approx. 0.3	kg

Connection diagram

Switching element SK 2131

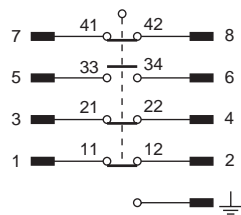

Safety Interlocks

Series i100 S 2 (plug connector)

Type:	Basic housing EN 50041
Housing:	Anodized die-cast light alloy
Connection:	Plug connector SR 11 (see page 58)
Switching elements:	4 contacts

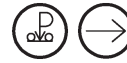

Dimensional drawing

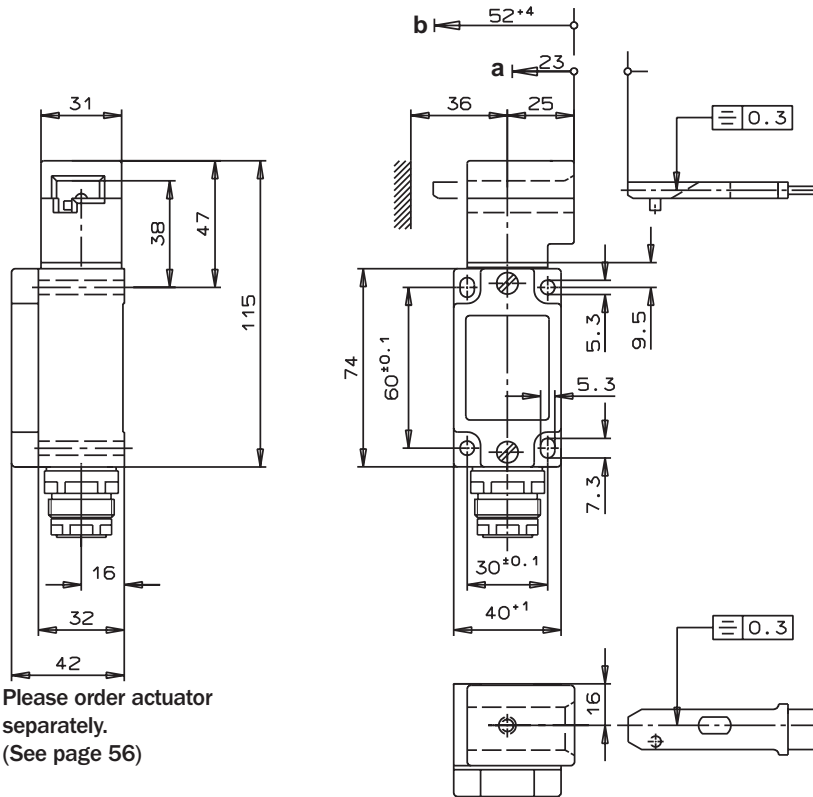

Switching elements

SK 2131 Slow-action interlock
3 positively driven NC + 1 NO contact
(See page 101 for further details)

Installation notes

The safety interlock and actuator must be assembled for installation purposes. The actuator must be positively connected with the mounting surface, e.g. by using safety screws or by welding, riveting, pinning. The safety interlock must not be used as an end stop.

a) Pre-travel:

The actuator is in the guide, but does not initiate switching operation.

b) Switching operation complete:

The actuator must be inserted up to this point to ensure reliable switching.
The actuator must be withdrawn at least to point a for switching off.

Changing the approach direction

The actuator head can be turned to the desired approach direction after undoing the fixing screws. The working illustration is as shown (approach direction E).

Warning

The complete safety interlock should be replaced in the event of damage or wear.

Dimensions plug connector connection SR 11

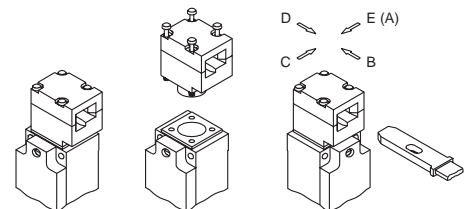
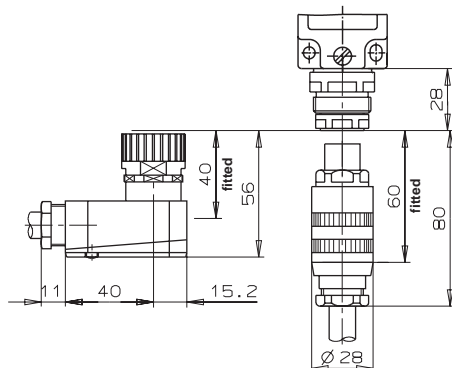

Technical data

Parameter	Value	Unit
Housing material	Anodized die-cast light alloy	
Environmental protection to IEC 529	IP 65	
Mounting position	optional	
Mechanical service life	2 x 10 ⁶ Switching cycles	
Ambient temperature	- 25 to + 80	°C
Approach speed max.	20	m/min
Actuating force	35	N
Switching element	SK 2131	
Contact elements	3 NC ⊖ + 1 NO	
Switching principle	Slow-action	
Rated impulse withstand voltage U _{imp}	4.0	kV
Rated insulation voltage U _i	50	V≅
Utilization category to IEC 947-5-1	AC-15 U _e 50 V I _e 6 A / DC-13 U _e 24 V I _e 6 A	
Switching voltage min.	12	V
Switching current min. at 24 V	10	mA
Contact material	Silver alloy, gold flashed	
Connection type	Plug connector 11 + PE (DIN 43651)	
Short-circuit protection (control circuit fuse)	slow 10/20 fast	A
Weight	approx. 0.35	kg

Connection diagram

Switching element SK 2131

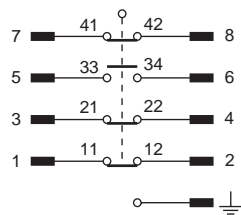

Ordering table i100

Safety Interlocks

Type	Actuator			Connector		Part number
	Roller Lever	Roller Plunger	Separate Actuator Key	PG 13.5	SR 11	
i100-	R			1		6 012 142
i100-		P		1		6 012 129
i100-			S	1		6 012 130
i100-	R				2	6 012 131
i100-		P			2	6 012 132
i100-			S		2	6 012 133

Switching elements: 3 NO contacts/1 NC contact as standard. Other switching elements on request.

Heavy duty accessories

A wide range of accessories for all SICK heavy duty safety interlock series.

Use

To be used in conjunction with variable actuator directions for almost all applications.



Actuators for Safety Interlocks Category 2

SICK category 2 safety interlocks can be operated only with an actuator which is specifically intended for the interlock in question. This actuator initiates an exactly defined functional sequence in the safety interlock. This guarantees optimum protection against unintentional actuation and manipulation.

The actuator comprises a laminated spring steel core coated with abrasion-resistant plastic to guarantee maximum reliability combined with minimum wear.

Two straight actuators and **four hinged actuators** are available to meet the needs of an extremely wide variety of applications.

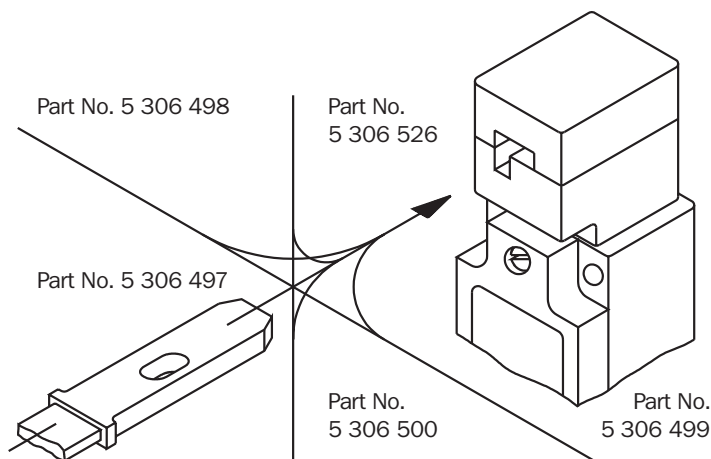

The actuators must be fitted on their mounting surface by means of a positive connection in accordance with the applicable regulations (e.g. VDI 2854), i.e. they must be welded, riveted or otherwise secured to prevent them from being detached. The actuator and safety interlock must be assembled together for installation in order to ensure reliable operation.

Actuators must not be used as guides or end stops in conjunction with safety interlocks. Safety guard bolts must be used if this task cannot be solved by design measures.

SICK safety guard bolts are available for all safety interlocks of the type series i100 and i100 Lock.

Standard actuator

with 4 mm overtravel, door radius min. 1000 mm, with two safety screws for each actuator

Part No. 5 306 497

Unit 1 pc.

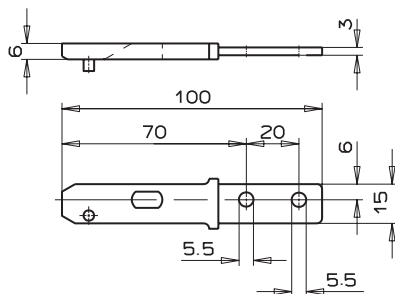

Straight actuator

Installation example: Sliding cover

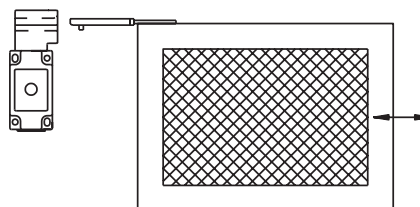

Actuator

with 16 mm overtravel, door radius min. 1000 mm, with two safety screws for each actuator

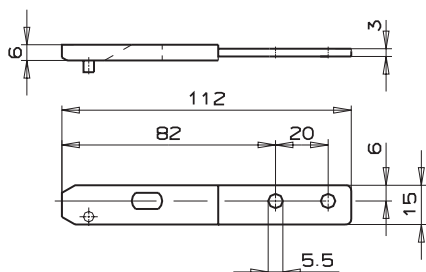

Actuators for Safety Interlocks Category 2

Hinged actuator

with 2 safety screws
for each actuator
Part No. 5 306 498
Unit 1 pc.

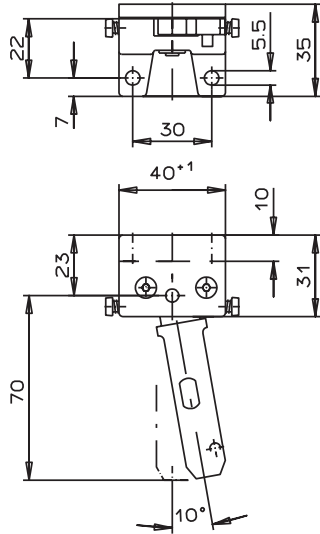

Hinged actuator iE 100-R 1

Door hung on left

Installation example (top view)

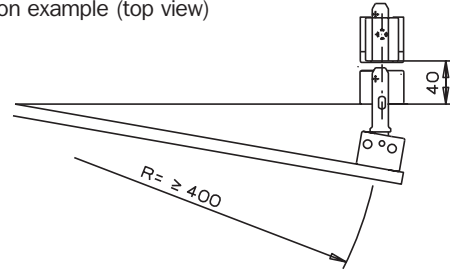

Hinged actuator

with 2 safety screws
for each actuator
Part No. 5 306 499
Unit 1 pc.

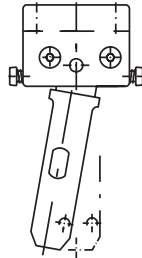

Hinged actuator iE 100-R 2

Door hung on right

Installation example (top view)

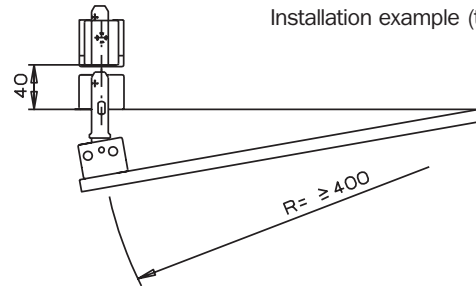

Hinged actuator

with 2 safety screws
for each actuator
Part No. 5 306 500
Unit 1 pc.

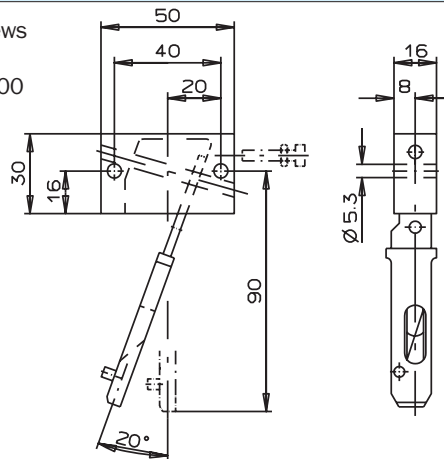

Hinged actuator iE 100-R 3

Safety flap hung at bottom

Installation example

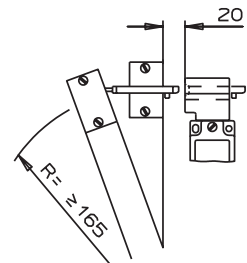

Hinged actuator

with 2 safety screws
for each actuator
Part No. 5 306 526
Unit 1 pc.

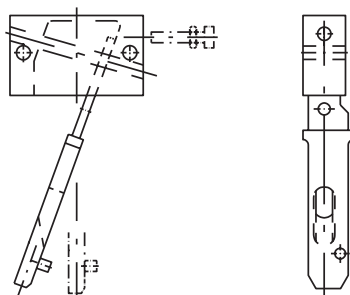

Hinged actuator iE 100-R 4

Safety flap hung at top

Installation example

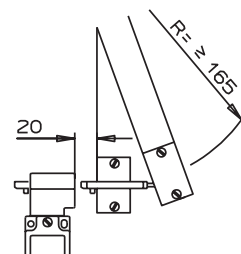

Accessories Connectors

Connectors

Safety interlocks are available with plug connectors for certain applications, e.g. where fast replacement is important. Alternatively, connectors can be retrofitted by the user.

SICK offers a range of high quality connectors:

Plastic encapsulated (DIN 43651, 6 and 11 poles)

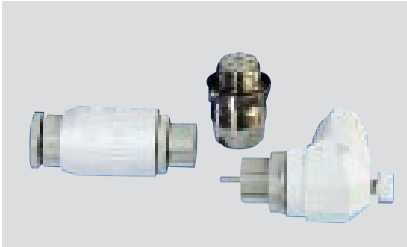

Technical data

Parameter	Value
Housing material	plastic
Number of pins	12 (11 + PE)
Nominal voltage (11 + PE)	50 V ~/=
Enclosure rating acc. to IEC 529	IP 65 (fitted)
Type of connection	crimp contacts 0.5 ... 1.5 mm ²

Accessories Connectors – Lockout bar

Lockout bar

Part No.: 5 603 534

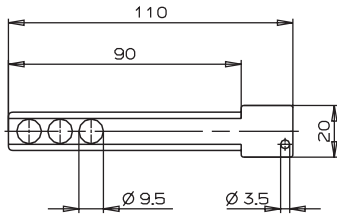

The locking insert can be inserted in the safety interlock instead of the actuator when the safety guard is in open condition and can then be secured to prevent removal by standard commercially available padlocks (max. 3 pcs.). This guarantees reliable protection for persons who have to enter potentially hazardous areas.



Ordering table iE 100

Actuator for i100 Lock and i100

Type	Actuator Type straight	Radius: door hinged				Lockout Bar	Part number
		left side	right side	lower side	upper side		
iE100-	S 1						5 306 497
iE100-		R 1					5 306 498
iE100-			R 2				5 306 499
iE100-				R 3			5 306 500
iE100-					R 4		5 306 526
iE100-						S 2	5 306 534

Ordering table

PG cable gland/plug for i100 Lock, i100, i190 Lock and i10

Type		Number of pins	Part number
SSR 11, cable receptacle	straight	11 + PE	6 020 757
ASR 11, cable receptacle	angled	11 + PE	6 020 758
Device plug	for safety interlock	11 + PE	6 020 759
PG 13.5			5 305 811

Ultra heavy duty which interlock solution do you require?

The modular construction of the high-end ultra heavy duty series provides numerous solutions for the most varied of safeguarding systems. The system can be adapted or expanded at any time. The following selection guide lists possible requirements and challenges and helps in your selection of the most suitable solution modules.

Are you looking for a solution with solenoid release?

You will find detailed information on **pages**

61–68

Are you looking for a solution without solenoid release?

You will find detailed information on **pages**

69–74

Are you looking for a solution with integrated restart function?

The door can only be opened or closed deliberately. The accidental closing of the door does not trigger a machine start.

You will find detailed information on **pages**

66–70

Are you looking for a solution with access function?

Access to the machine is only granted to those with a key.

You will find detailed information on **page**

75

Are you looking for a solution with enable function?

The machine can only be started from inside with an access key.

You will find detailed information on **page**

75

Do you need a status indicator visible from a distance?

You will find detailed information on **page**

76

Ultra heavy duty with solenoid release

Maximum reliability with dual-channel safety switching with and unique modular construction.

Use

Always necessary when the access time is *less* than the machine stop time.



Function – details – options

Applications

These extremely robust electro-mechanical safety interlocks provide unique modular solutions for safety applications. They allow simple selection of the components required for safeguarding work processes and machines.

Construction

The safety interlocks of this series are extremely robust thanks to their housing made of zinc alloy and stainless steel components. Their reliability has been tested for more than 1,000,000 switching actions.

Their simple modular construction allows optimal function-oriented use in any applications.

Function

The gate is closed and voltage applied when the machine is in operation. If access is required, the actuator is simply separated from the unit by the opening of the gate and the switching contact is forced open via positive mechanical operation. A red LED indicator lamp lights up at this moment. Despite its simple operating principle this series provides double safety: for the machine operator and for the machine.

Flexibility

Apart from their modular construction, these safety interlocks also offer integrated flexibility for protecting personell and machinery:

- Variable approach directions
(4 x 90°)
- Variable handle position (only for devices with a handle)
(8 x 45°)
- Alignment error tolerance tongue – only for devices with a tongue (automatic adjustment ± 12 mm)

LED indicators

All safety interlocks in this series have an LED status indicator. It provides a visual check of the current state of the device.

Function – details – options

Turning the head

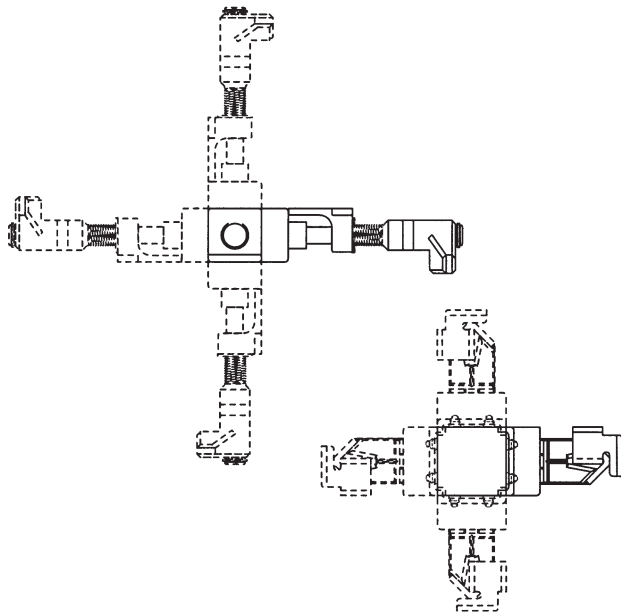

Actuator alignment error tolerance

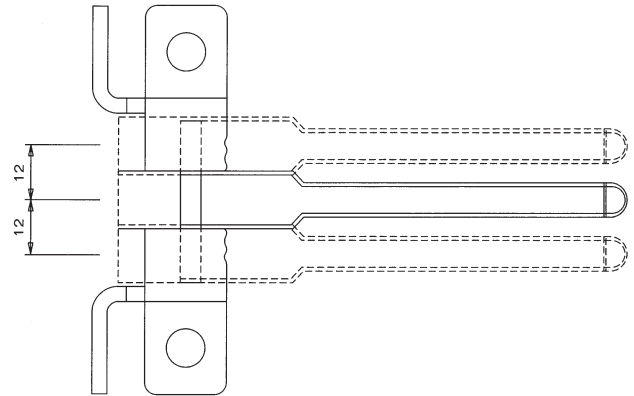

Turning the handle

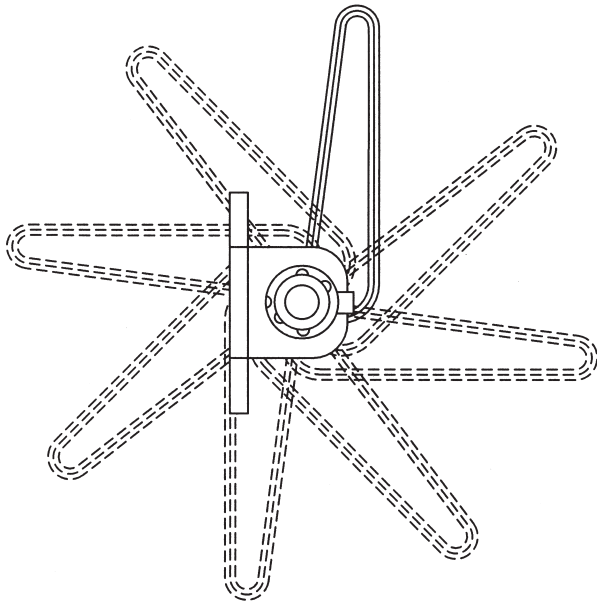

Safety Interlocks

i1002 Lock

Housing:	Cast housing in zinc alloy with polyester coating
Connection:	PG 13.5 threaded
Contacts:	4 x NC + 2 x NO

 Approvals applied for
Explosive area zone 2

Dimensional drawing

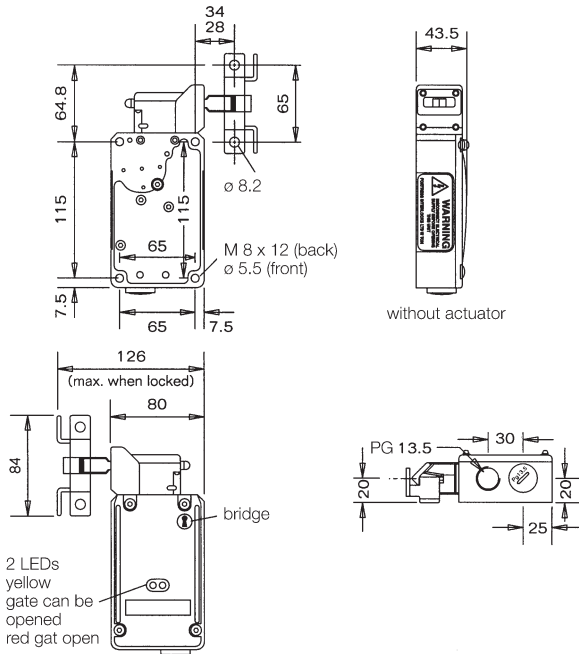

Function / LED indicators

When the machine is in operation, the device securely traps the actuator on the movable gate: a solenoid operated mechanism holds it firmly in place. In order to open gates in the protective fence the machine operator must first switch off the machine at the control panel. The internal solenoid is activated only when the machine has come to a complete stop. At this moment, a *yellow* indicator light signals that the actuator can be released. After release a *red* indicator light signals that access is allowed.

Installation

The machine's protective fence must be drilled for mounting on the front or back. The main unit is normally mounted on a static part of the fence with the actuator on the entrance gates. The actuator can be mounted with any orientation on a sliding or hinged gate. The safety interlock must not be used as an end stop.

Changing the approach direction

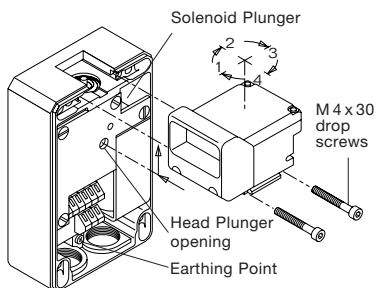

- Unscrew the cover.
- Loosen and remove both M 4 x 30 screws.
Hold plunger down with a small screwdriver (see arrow in the above diagram). Remove head.
- Re-insert screws; ensure that the head is correctly fixed. Replace cover.

Please note

The complete safety interlock must be replaced in the event of damage or wear.

Control voltages

24 V AC/DC $\pm 10\%$
 110 V AC/DC $\pm 10\%$
 230 V AC/DC $\pm 10\%$

Manual unlocking mechanism

Safety interlocks with manual solenoid release can be operated by means of a manual mechanism in the event of, for example, a power failure. The solenoid release can only be freed using the encoded key supplied. Unlocking can also be used in conjunction with the lockout bar.

Technical data

Parameter	Value	Unit
Housing material	zinc alloy and stainless steel	
Coating	powder-coated polyester	
Colour	black/yellow and stainless steel	
Enclosure rating	IP 67 (DIN 40 0050)	
Actuator turning moment	5	Nm
Retaining power, locked	2 500	N
Max. approach speed	20	m/min
Mechanical service life	> 10 ⁶ switching actions	
Max. frequency of use	7 200	/h
Ambient temperature	- 5 to + 40	°C
Max. cross-section of cables	2.5	mm ²
Connection	vibration-proof snap-on binding block	
Switching conformity	DIN VDE 0660 part 206 & IEC 947-5-1	
Switching contacts	4 x NC + 2 x NO	
Contact type	captive opening	
Switching current	max. 10 A	
Switching voltage	max. 230 V AC	
Insulating gap	2 x 2 mm per switching contact	
Contact material	90 % silver and 10 % nickel	
Utilisation category	AC 15 or DC 13	
Operating voltages	24 V AC/DC, 110 V AC or 230 V AC	
Insulation resistance	20	MΩ
Insulation voltage	2 500	V AC
Coil magnet nominal power	12	W
Coil current at 24 V DC nominal voltage	500	mA
Coil magnet – operating voltages – voltage tolerance	24 V AC/DC, 110 V AC or 230 V AC 85 % to 110 % of nominal value	

Accessories available

- Adapter for safety key
- Adapter for access key
- Option housing
- Blocking clip

Circuit diagram

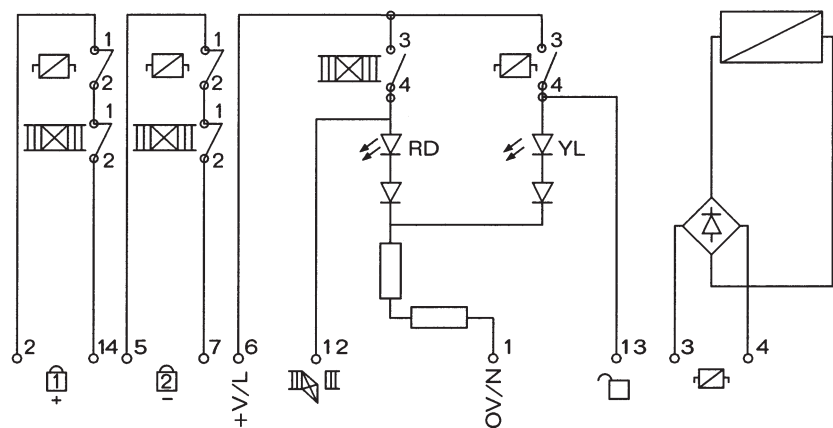

Safety Interlocks

i1001 Lock

Housing:	Cast housing in zinc alloy with polyester coating
Connection:	PG 13.5 threaded
Contacts:	2 x NC + 1 x NO



Approvals applied for
Explosive area zone 2

Dimensional drawing

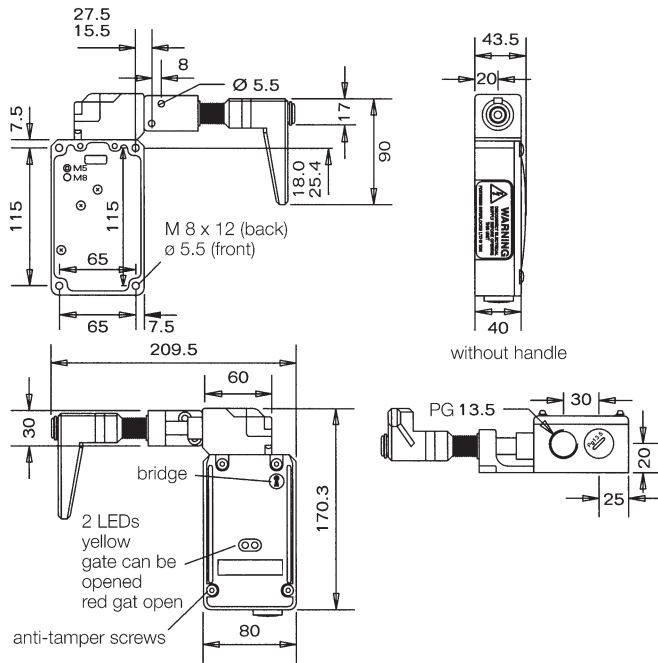

Function / LED indicators

When the machine is in operation, the device securely traps the handle and the gate is firmly locked: a solenoid operated mechanism prevents the handle from being pulled out. In order to open gates in the protective fence the machine operator must first switch off the machine at the control panel. The internal solenoid is activated only when the machine has come to a complete stop. At this moment, a yellow indicator light signals that the handle can be removed. After removal a red indicator light signals that access is allowed.

Installation

The machine's protective fence must be drilled for mounting on the front or back. The main unit is normally mounted on a static part of the fence with the actuator on the entrance gates. The actuator can be mounted with any orientation on a sliding or hinged gate. The safety interlock must not be used as an end stop.

Changing the approach direction

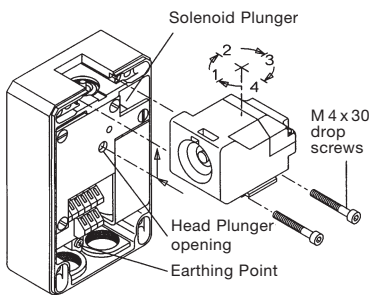

- Unscrew the cover.
- Loosen and remove both M 4 x 30 screws.
Hold plunger down with thin screwdriver (see arrow in the above diagram). Remove head.
- Re-insert screws; ensure that the head is correctly fixed. Replace cover.

Control voltages

24 V AC/DC ± 10 %
110 V AC/DC ± 10 %
230 V AC/DC ± 10 %

Mechanical unlocking mechanism

Safety interlocks with mechanical solenoid release can be released by means of the unlocking mechanism in the event of, for example, a power failure. The solenoid release can only be freed using the encoded key supplied. Unlocking can also be used in conjunction with the lockout bar.

Please note

The complete safety interlock must be replaced in the event of damage or wear.

Technical data

Parameter	Value	Unit
Housing material	zinc alloy and stainless steel	
Coating	powder-coated polyester	
Colour	black / yellow and stainless steel	
Enclosure rating	IP 67 (DIN 40 0050)	
Actuator turning moment	5	Nm
Retaining power, locked	2 500	N
Max. approach speed	20	m/min
Mechanical service life	> 10 ⁶ switching actions	
Max. frequency of use	7 200	/h
Ambient temperature	- 5 to + 40	°C
Max. cross-section of cables	2.5	mm ²
Connection	vibration-proof snap-on binding block	
Switching conformity	DIN VDE 0660 part 206 & IEC 947-5-1	
Switching contacts	4 x NC + 2 x NO	
Contact type	captive opening	
Switching current	max. 10 A	
Switching voltage	max. 230 V AC	
Insulating gap	2 x 2 mm per switching contact	
Contact material	90% silver and 10% nickel	
Utilisation category	AC 15 or DC 13	
Operating voltages	24 V AC/DC, 110 V AC or 230 V AC	
Insulation resistance	20	MΩ
Insulation voltage	2 500	V AC
Coil magnet nominal power	12	W
Coil current at 24 V DC nominal voltage	500	mA
Coil magnet duty cycle	100	%
Coil magnet – operating voltages – voltage tolerance	24 V AC/DC, 110 V AC or 230 V AC 85% to 110% of nominal value	

Accessories available

- Adapter for safety key
- Adapter for lockout bar
- Optional housings
- Bridging key switch
- Blocking clip
- Emergency-off switch

Circuit diagram

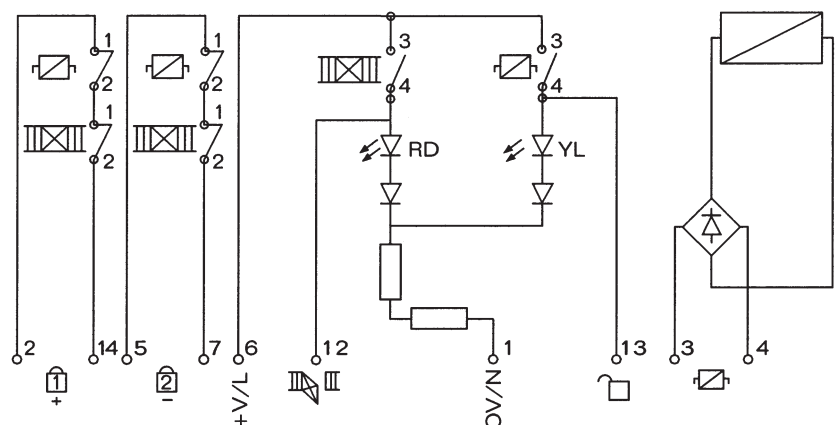

Ordering table

Safety Interlocks with solenoid release

Type	Solenoid voltage			Part number
	24 V AC/DC	110 V AC	230 V AC	
i1001 Lock	24			6 021 013
		110		6 021 014
			230	6 021 015
i1002 Lock	24			6 021 007
		110		6 021 008
			230	6 021 009

Ultra heavy duty without solenoid release

This highly robust and reliable safety interlock offers a dual-channel safety circuit and unique modular construction.

Use

This series provides optimal protection for applications whose access time is *greater* than the plant or machine stop time.



Housing:	Cast housing in zinc alloy with polyester coating
Connection:	PG 13.5 threaded
Contacts:	2 x NC + 1 x NO



Dimensional drawing

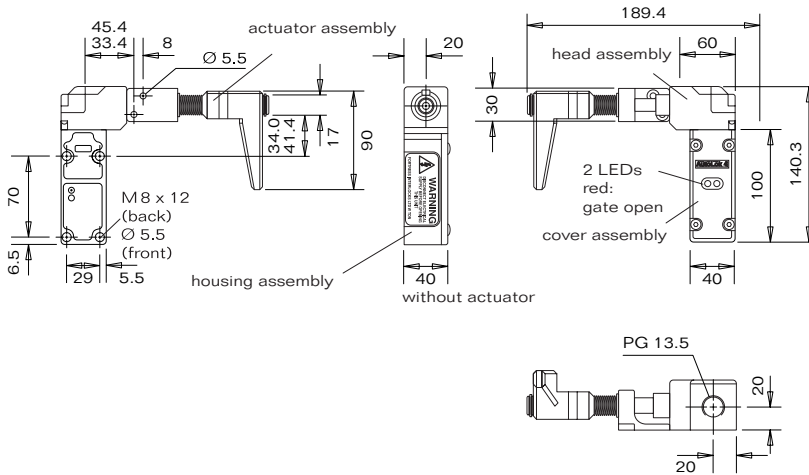

Please note

The complete safety interlock must be replaced in the event of damage or wear.

Installation

The machine's protective fence must be drilled for mounting on the front or back. The main unit is normally mounted on a static part of the fence with the actuator on the entrance gates. The actuator can be mounted with any orientation on a sliding or hinged gate. The safety interlock must not be used as an end stop.

Control voltages

24 V AC/DC $\pm 10\%$
 110 V AC/DC $\pm 10\%$
 230 V AC/DC $\pm 10\%$

Accessories available

Adapter for safety key
 Adapter for access key
 Lockout bar

Changing the approach direction

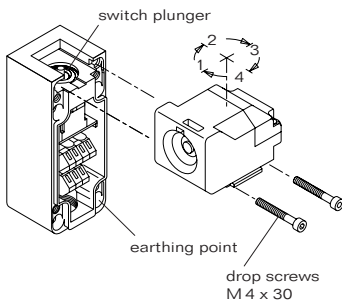

- Unscrew the cover.
- Loosen and remove both M 4 x 30 screws and remove head from the side.
- Reposition head and base. A pre-tensioned piston prevents the head from moving all the way back. Use a small screwdriver to release the piston tension so that the head can be returned to its original depth.
- Replace cover screws. Ensure that the head is correctly fixed before replacing the cover.

Technical data

Parameter	Value	Unit
Housing material	zinc alloy and stainless steel	
Coating	powder-coated polyester	
Colour	black/yellow and stainless steel	
Enclosure rating	IP 67 (DIN 40 0050)	
Actuator turning moment	5	Nm
Retaining power, locked	2 500	N
Max. approach speed	20	m/min
Mechanical service life	>10 ⁶ switching actions	
Max. frequency of use	7 200	/h
Ambient temperature	- 5 to + 40	°C
Max. cross-section of cables	2.5	mm ²
Connection	vibration-proof snap-on binding block	
Switching conformity	DIN VDE 0660 part 206 & IEC 947-5-1	
Switching contacts	2 x NC + 1 x NO	
Contact type	captive opening	
Switching current	max. 10 A	
Switching voltage	max. 230 V AC	
Insulating gap	2 x 2 mm per switching contact	
Contact material	90% silver and 10% nickel	
Utilisation category	AC 15 or DC 13	
Operating voltages	24 V AC/DC, 110 V AC or 230 V AC	
Insulation resistance	20	MΩ
Insulation voltage	2 500	V AC

Circuit diagram

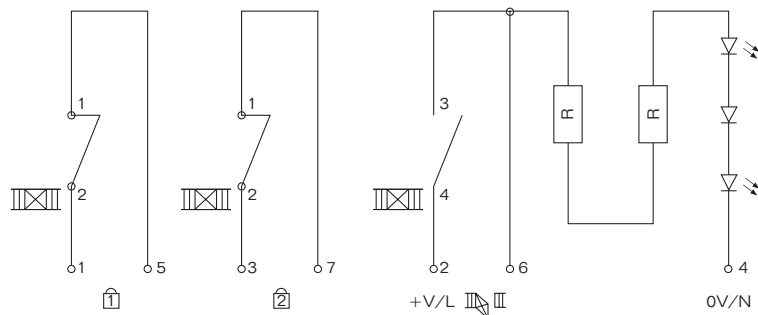

Housing:	Cast housing in zinc alloy with polyester coating
Connection:	PG 13.5 threaded
Contacts:	2 x NC + 1 x NO



Dimensional drawing

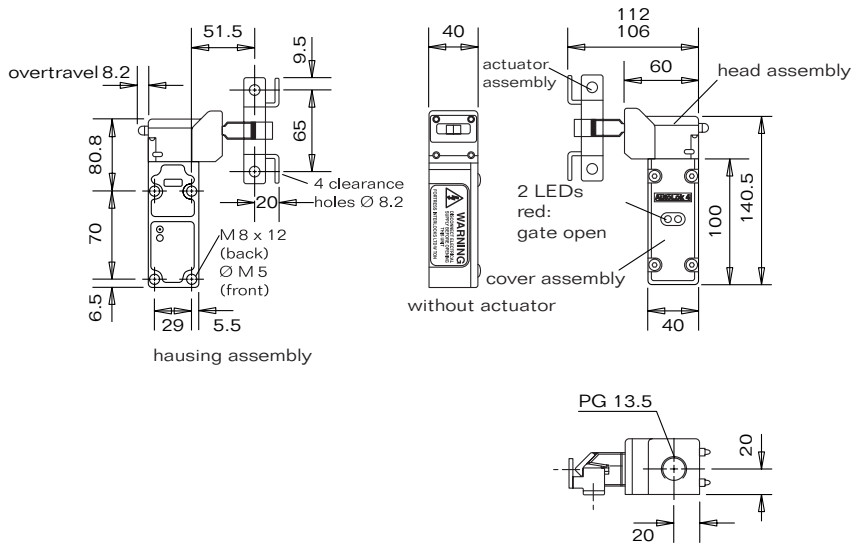

Please note

The complete safety interlock must be replaced in the event of damage or wear.

Installation

The machine's protective fence must be drilled for mounting on the front or back. The main unit is normally mounted on a static part of the fence with the actuator on the entrance gates. The actuator can be mounted with any orientation on a sliding or hinged gate. The safety interlock must not be used as an end stop.

Control voltages

24 V AC/DC $\pm 10\%$
 110 V AC/DC $\pm 10\%$
 230 V AC/DC $\pm 10\%$

Accessories available

Adapter for safety key
 Adapter for access key
 Lockout bar

Changing the approach direction

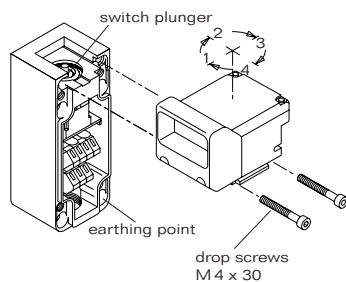

- Unscrew the cover.
- Loosen and remove both M 4 x 30 screws and remove head from the side.
- Reposition head. A pre-tensioned piston prevents the head from moving all the way back. Use a small screwdriver to release the piston tension so that the head can be returned to its original depth.
- Replace cover screws. Ensure that the head is correctly fixed before replacing the cover.

Technical data

Parameter	Value	Unit
Housing material	zinc alloy and stainless steel	
Coating	powder-coated polyester	
Colour	black /yellow and stainless steel	
Enclosure rating	IP 67 (DIN 40 0050)	
Actuator turning moment	5	Nm
Retaining power, locked	2 500	N
Max. approach speed	20	m/min
Mechanical service life	>10 ⁶ switching actions	
Max. frequency of use	7 200	/h
Ambient temperature	- 5 to + 40	°C
Max. cross-section of cables	2.5	mm ²
Connection	vibration-proof snap-on binding block	
Switching conformity	DIN VDE 0660 part 206 & IEC 947-5-1	
Switching contacts	2 x NC + 1 x NO	
Contact type	captive opening	
Switching current	max. 10 A	
Switching voltage	max. 230 V AC	
Insulating gap	2 x 2 mm per switching contact	
Contact material	90% silver and 10% nickel	
Utilisation category	AC 15 or DC 13	
Operating voltages	24 V AC/DC, 110 V AC or 230 V AC	
Insulation resistance	20	MΩ
Insulation voltage	2 500	V AC

Circuit diagram

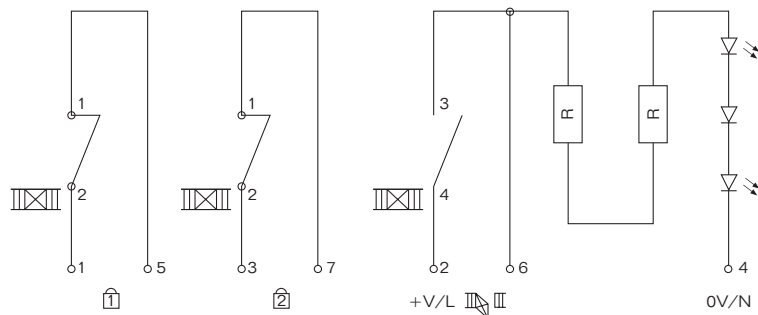

Ordering table

Safety interlocks without solenoid release

Type	Voltage 24 V AC/DC	110 V AC	230 V AC	Part number
i1001	24			6 021 016
		110		6 021 017
			230	6 021 018
i1002	24			6 021 010
		110		6 021 011
			230	6 021 012



Modular options

Each basic unit can be supplemented by various optional housings: key module, emergency-off module, and control lamp module.

Use

Simple adaptation of the basic system to individual applications.

Options

Safety key adapter

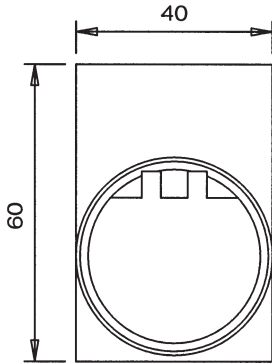

Located between the unit's head and its housing. The key is securely held in the unit and the gate is kept closed. Access is only possible when the key has been turned and removed.

For use with i1001
i1002
i1002 Lock



Access key adapter

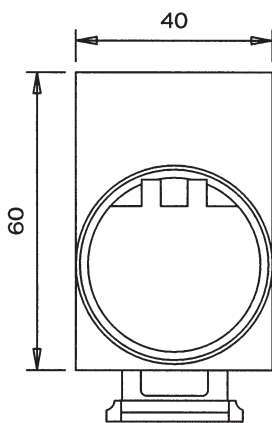

The adapter is identical to the above-mentioned safety key – except for its function. The gate is locked if there is no key in the adapter; the gate can only be opened when a key has been inserted and moved (access permission).

Housings

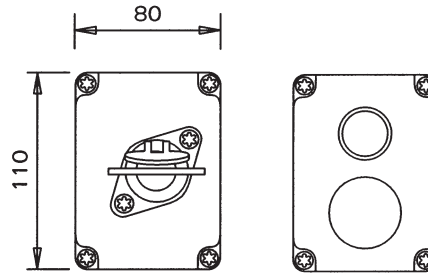

Housings are available in three different designs. Each of them can accept the solenoid controlled elements: the key switch, press button and indicator lamp.

They offer great flexibility, e.g. for the stop functions. They are simply mounted below the particular unit.

Key switch IE 1000 AK
contact set 2 x NO + 2 x NC for connections into the machine's stop circuit.

Push button IE 1000 ER
provides signals that are connected into the machine's control system (e.g. stop command).

Indicator lamp IE 1000 ML
improves the visibility of the LED indicator lights

For use with i1002 Lock
i1001



Lockout bars

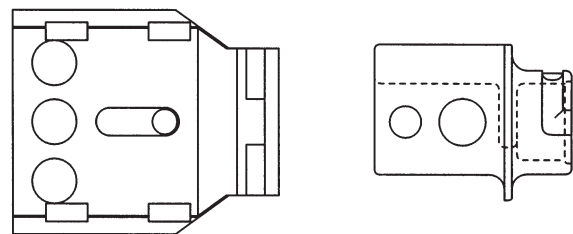

Lockout bar for actuator

Lockout bar for actuator handle

As soon as they have been attached to the head and fixed into their operating position, gates can no longer be closed and therefore no machine start is possible without deliberate actuation.

For use with i1001
i1002
i1002 Lock

Options

Emergency-stop / Restart button



Accessories

Ordering table

Accessories

Type			Part number
iE 1002	S 3	Lockout bar	5 308 312
	R 1	Lockout bar	5 308 313
		3 mm/1/4" Inbus safety screws	5 308 317
		Key for emergency unlocking i1001	5 308 320
Actuator			
iE 1002	S 2		5 308 315
iE 1001	R 1		5 308 316



Actuator iE 1002 S 2



Lockout bars iE 1002 S 3



Actuator iE 1001 R 1

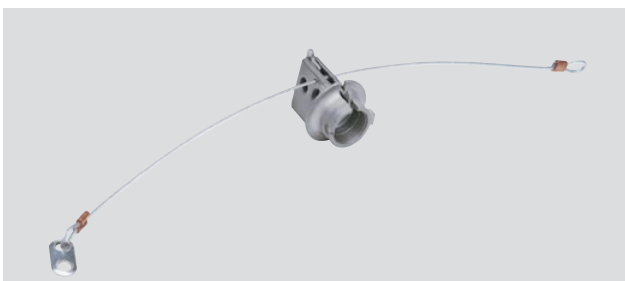

Lockout bars iE 1002 R 1



Ordering table

Safety key adapters

Type	Coding					Part number
	1	2	3	4	5	
iE 1000	SK 1					5 308 297
		SK 2				5 308 298
			SK 3			5 308 299
				SK 4		5 308 300
					SK 5	5 308 301



Ordering table

Access key adapters

Type	Coding					Part number
	1	2	3	4	5	
iE 1000	AK 1					5 308 302
		AK 2				5 308 303
			AK 3			5 308 304
				AK 4		5 308 305
					AK 5	5 308 306



Ordering table

Keys

Type	Coding					Part number
	1	2	3	4	5	
iE 1000	K 1					5 308 307
		K 2				5 308 308
			K 3			5 308 309
				K 4		5 308 310
					K 5	5 308 311



Ordering table

Enabling unit

Type	Coding					Part number
	1	2	3	4	5	
iE 1000	ES 1					6 021 019
		ES 2				6 021 020
			ES 3			6 021 021
				ES 4		6 021 022
					ES 5	6 021 023



Ordering table

Emergency-stop/Restart unit

Type	Coding	Part number
iE 1000	ER	6 021 024



Ordering table

Status/indicator light unit

Type	Coding	Part number
iE 1000	ML	6 021 025



T 4000 Non-contact Safety Interlocks

Non-contact safety interlocks with electronically encoded actuator for the ultimate prevention of manipulation.

Use

The ideal interlock for large and heavy doors (also those with imprecise alignment), for increased demands regarding hygiene as well as when extreme vibrations are present. Conforms to control category 4.



Advantages

- Unambiguous encoded actuator (unique)
 - ➔ absolutely proof against manipulation
- Integrated safety switching device
- Two redundant relay outputs with internal monitored contacts
 - ➔ Control Category 4
- Error diagnosis possible
- Self-testing without opening of the protective system
- Large mechanical tolerances for door alignment possible
- Small actuator and reading head construction shape
- Flush mounting in the door panelling
- Can be mounted behind metal

System description

The non-contact safety interlock T 4000 consists of three components:

- Coded actuator
- Read head
- Evaluation unit

Each actuator supplied features a unique electronic code and is thus unique to the system used. The code of an actuator cannot be reprogrammed.

The read head is mounted on the stationary part of the safety guard and is connected to the evaluation unit via a two-core, screened cable.

The actuator mounted on the safety guard is moved towards the read head when the door is closed. When the switch-on distance is reached, power is supplied to the actuator via the inductive read head and the data can be transferred. The bit pattern read in is compared with the stored code in the

evaluation unit. If the data corresponds, the relay outputs are enabled and the Enable output (semiconductor output) is also set to HIGH.

The evaluation unit reverts to safe state regardless of the particular error owing to dynamic sensing of the actuator and the redundant-diversity design of the safety circuitry. When the safety guard is open, the normally open contacts deactivate the safety circuit and the Enable output (OUT) is switched to Low. The status of the normally open contacts is monitored internally via positive-action normally closed contacts. In the event of an internal error in the evaluation unit, the safety circuit is also deactivated and the diagnostic output (ERROR) is set to High. The ERROR LED then lights red.

Note: The dwell time of an actuator inside and outside the operating range must be at least 0.5 seconds. Otherwise, the evaluation unit reverts to Error status and the ERROR LED lights red. The evaluation unit can be reset to Operating state by disconnecting the power supply.

Function test (self-test)

On electromechanical safety interlocks or solenoid interlocks, the function test can be conducted by cyclically opening the safety guard.

As of control category 2, a function test of the entire safety system must be conducted in accordance with EN 60204-1: 1997 (Chapter 9.4.2.4) on start-up or at stipulated intervals.

It is not necessary to test the internal function of the safety interlock T 4000 since the device monitors itself in real time: Welding of an output contact is detected by the unit at the latest the next time the safety guard opens. A cross-fault of the relay

output lead is not detected by the unit. Moreover, the entire safety circuit can be tested without opening the safety guard. Opening of the safety guard is simulated for this purpose by applying 24 V DC to the test input.

The relay outputs are deactivated, thus allowing testing of the entire safety circuit. The diagnostic output ERR is also set to HIGH by the evaluation unit as a monitoring function.

When the test input is reset, the evaluation unit resets the diagnostic output ERR back to LOW, the red LED goes out and the relay outputs are activated again.

This allows a self-test to be conducted on the safety system without opening the safety guard.

Connection and block diagram

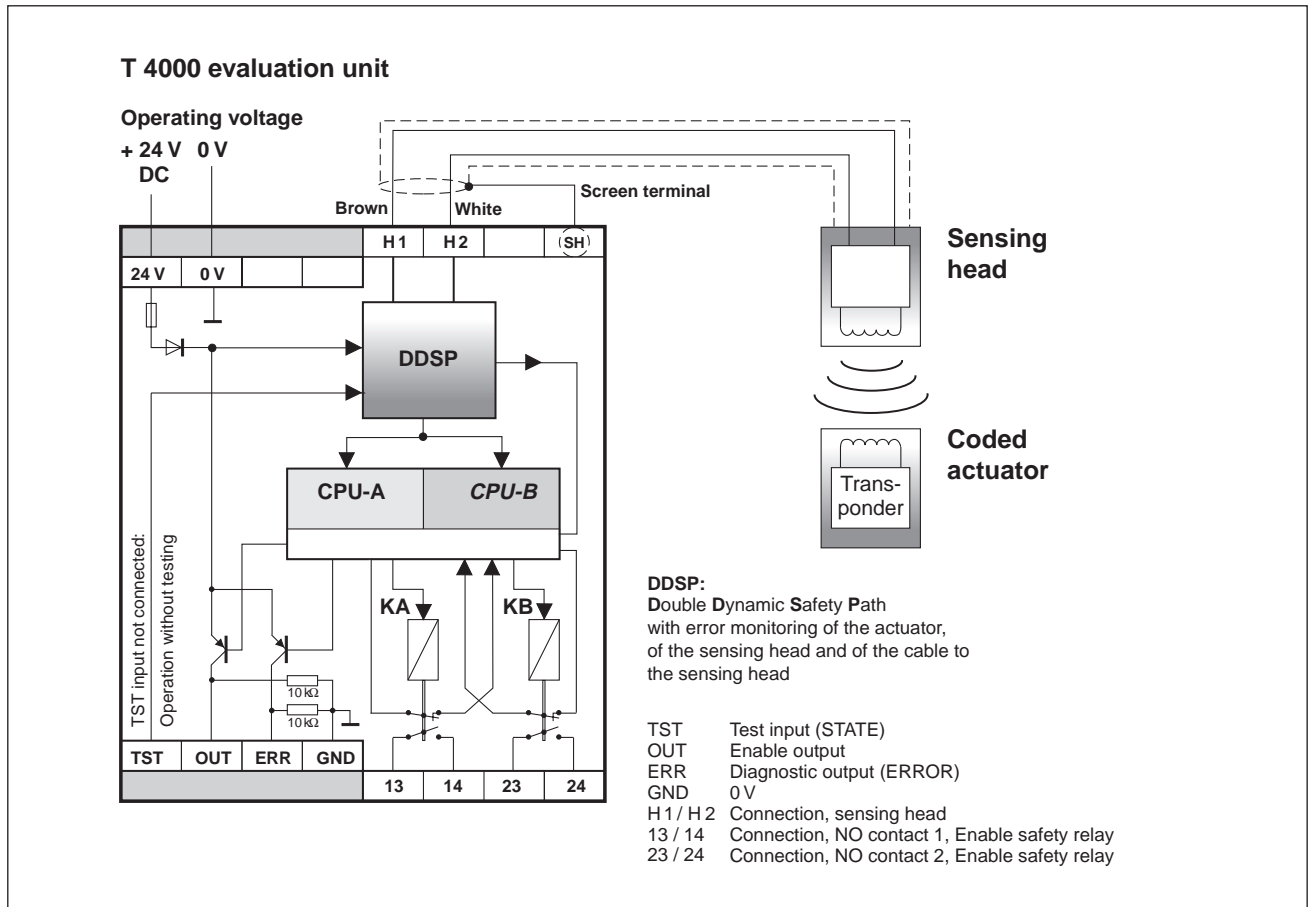

Typical operating range T 4000

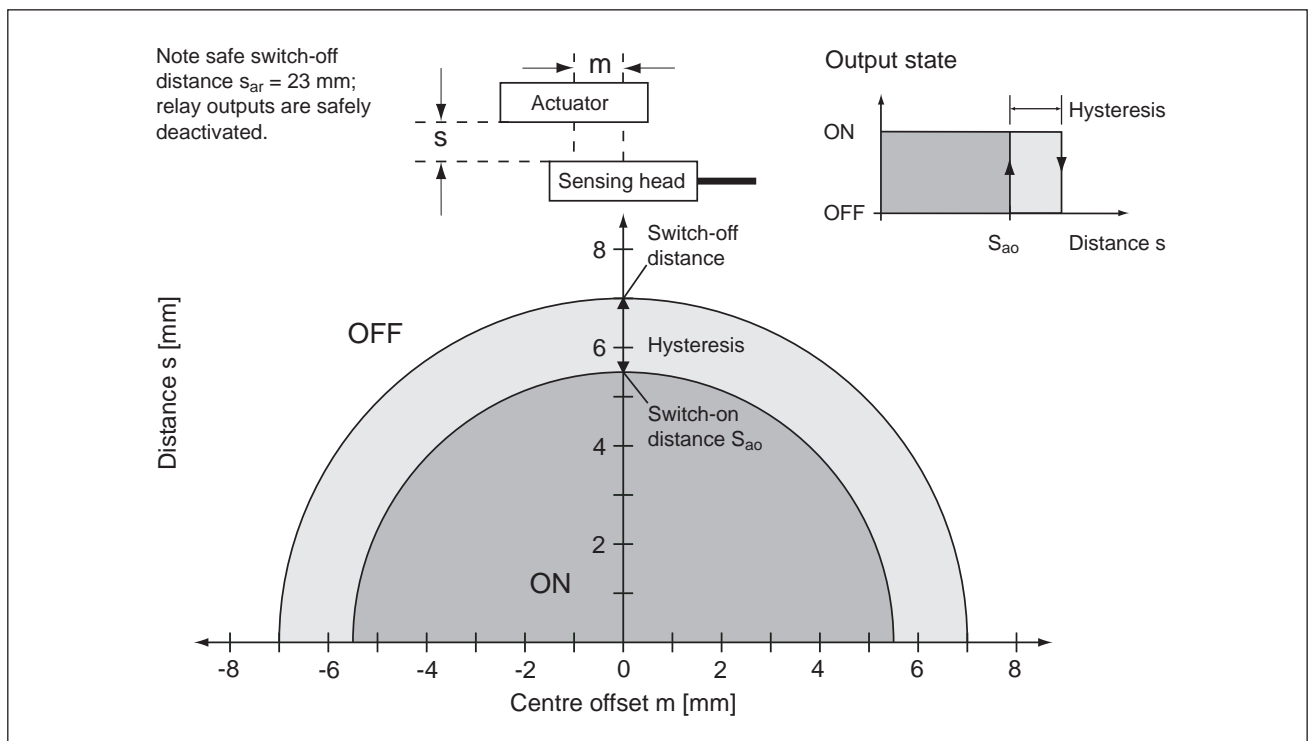

Evaluation unit

Dimensional drawing

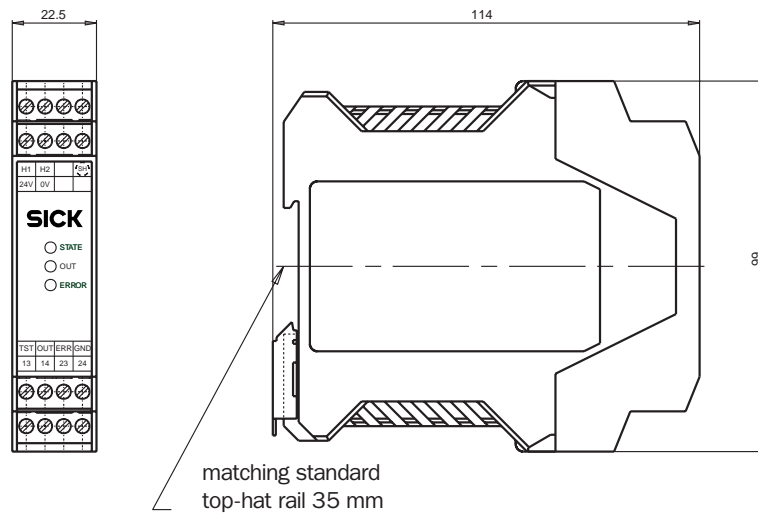

Technical data

Parameter	Value			Unit
	min.	typical	max.	
Housing material	Plastic PA 6.6			
Dimensions	114.5 x 99 x 22.5			mm
Mass	0.25			kg
Ambient temperature at $U_{op} = 24\text{ V DC}$	0	–	+ 55	°C
Storage temperature	– 25	–	+ 70	°C
Enclosure	IP 20			
Mounting	35 mm top-hat rail to DIN 46277			
Number of read heads	1 read head per evaluation unit			
Type of connection	plug-in screw-type terminals			
Connection terminals	0.14	–	2.5	mm ²
Operating voltage U_{op} (stabilised, residual ripple < 5 %)	21	24	27	V DC
Current consumption	150			mA
Safety outputs	2 safety relays, each with one NO contact			
Switching voltage (relay outputs)	10	–	60	V AC/DC
Switching current (relay outputs)	1	–	300	mA
External fusing	0.5 A medium slow-blow			
Utilisation category to EN 947-5-1	AC-12 U_{in} 60V 300 mA, DC-12 U_{in} 60V 300 mA			
Resistance to vibration	in accordance with EN 60 947-5-2			
Mechanical switching operations (relays)	30 x 106			
Operating delay as of state change	–	–	180	ms
Risk period ¹⁾	–	–	180	ms
Time delay before availability ²⁾	3			s
Alarm outputs (diagnostic ERR, Enable OUT, semiconductor output, p-switching) ³⁾				
– Output voltage	$0.8 \times U_{op}$	–	U_{op}	V DC
– Load rating	–	–	20	mA
Test input LOW	0	–	2	V DC
HIGH	15	–	U_{op}	V DC
EMC protection requirements to IEC 60947-5-3 (Draft)	complied with			
LED indicators	STATE	LED green blinking:	Normal mode Teach-In operation	
	OUT	LED yellow	Actuator detected	
	ERROR	LED red:	Test input activated Internal circuitry error Invalid Teach-In operation	

¹⁾ The risk period is the maximum switch-off delay after occurrence of an error. Welding of one of the relay outputs is only detected after opening of the safety guard.

²⁾ The relay outputs are deactivated and the alarm outputs are at LOW potential after switching on the operating voltage during the time delay before availability.

³⁾ Non-short-circuit-proof

Sensing head

Dimensional drawing

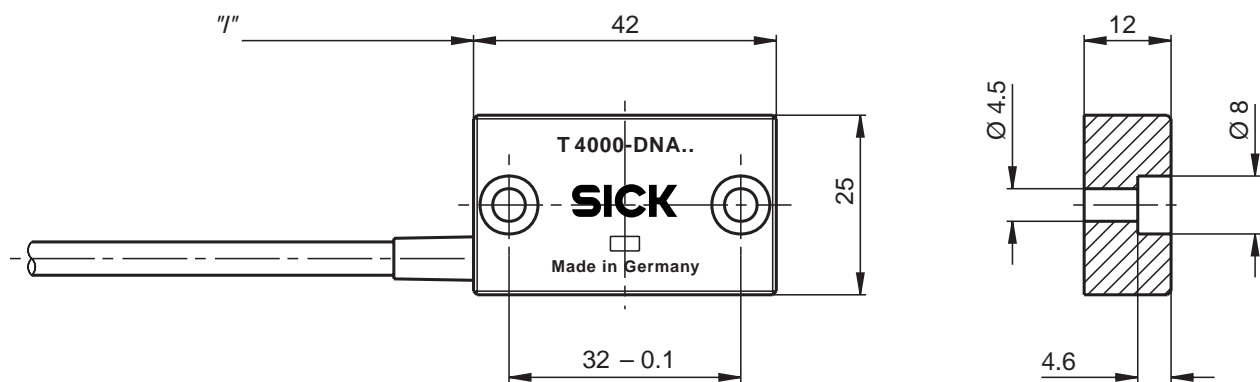

Two safety screws M4 x 16 included in scope of delivery.

Technical data

Parameter	Value			Unit
	min.	typical	max.	
Housing material	Fortron, glass-reinforced thermoplastic material; fully encapsulated			
Dimensions	40 x 25 x 12			mm
Mass (including 10 m cable)	0.3			kg
Ambient temperature	- 25	-	+ 70	°C
Enclosure	IP 67			
Installation position	any			
Mode of operation	inductive			
Dynamic data transfer to evaluation unit	2			kbit/s
Operating range in the case of centre offset $m = 0$				mm
– Switch-on distance S_{ao} ¹⁾	5	6	–	
– Differential hysteresis	–	2	–	
– Safe switch-off distance S_{ar} in the case of centre offset $m = 0$ mm ¹⁾	–	–	23	
Power supply	via evaluation unit			
Connection	permanently sealed connection cable, with wire end ferrules			
Line length	See Ordering /Type table; other lengths on request			

¹⁾ These values apply to non-flush and flush installation of the read head and of the actuator in aluminium. Moreover, these values apply only in conjunction with actuator T4000-KBA

Notes on installation

- The connection cable of the read head may not be lengthened.
- The alarm outputs and connection terminals for read head are non-short-circuit-proof
- The safety guard must be designed so that there is no risk up to a distance S_{ar} (safe switch-off distance).
Note: The relay outputs are safely deactivated, even in the case of an internal component failure, at the safe switch-off distance $S_{ar} = 23$ mm.
- Actuator and read head must be mounted so that:
 - the distance between the front faces is equal or less than the switch-on distance $0.8 \times S_{ao}$ (see Technical data) with the safety guard closed;
 - they are not used as a mechanical stop;
 - there must be a gap between the edge and the metal housing when flush-mounted;
 - they are connected keyed to the safety guard; e.g. by using the enclosed safety screws;

Actuator

Dimensional drawing

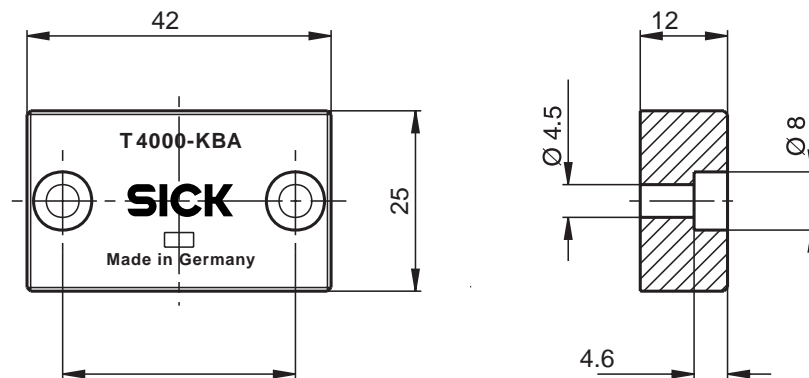

Two safety screws M 4 x 16 included in scope of delivery

Technical data

Parameter	Value			Unit
	min.	typical	max.	
Housing material	Fortron, glass-reinforced thermoplastic material, fully encapsulated			
Dimensions	40 x 25 x 12			mm
Mass	0.01			kg
Ambient temperature	- 25	-	+ 70	°C
Enclosure	IP 67			
Installation position	sensing face opposite read head			
Power supply	inductive via read head			
Dwell time within the switch-off distance	0.5	-	-	s

Notes on installation

- The safety guard must be designed so that there is no risk up to the distance S_{ar} (safe switch-off distance).
Note: The relay outputs are safely deactivated, even in the case of an internal component failure, at the safe switch-off distance $S_{ar} = 23$ mm.
- Actuator and read head must be mounted so that:
 - the distance between the front faces is equal or less than the switch-on distance $0.8 \times S_{so}$ (see Technical data) with the safety guard closed;
 - they are not used as a mechanical stop;
 - there must be a gap between the edge and the metal housing when flush-mounted;
 - they are connected keyed to the safety guard; e.g. by using the enclosed safety screws;

Teach-In function for actuator

Before the system forms a functional unit, the actuator must be assigned to the evaluation unit with the Teach-In function. During the Teach-In operation, the relay outputs and the alarm output are set to LOW, i.e. the system is in safe state.

4. The operating voltage on the evaluation unit must then be disconnected for min. 10 seconds in order to activate the new taught code of the actuator in the evaluation unit.

Teach-In function for first actuator (condition as delivered):

1. Apply the operating voltage to the evaluation unit
 - ➔ Fast blinking (approx. 4 Hz) of the green LED
2. Move the actuator towards the read head (note distance < S_{ao})
 - ➔ Teach-In operation commences; slow blinking (approx. 1 Hz) of the green LED
3. Teach-In operation complete (after 60 seconds)
 - ➔ Green LED goes out
4. The operating voltage applied to the evaluation unit must then be disconnected for min. 10 seconds in order to activate the taught code of the actuator in the evaluation unit.

Note:

- It is not possible to teach the same actuator on the same evaluation unit more than once.
- The number of valid teach-in operations on one evaluation unit is limited to max. 8.
- The evaluation unit can be operated only with the last actuator taught.
- A Teach-In operation is invalid if:
 - ➔ the Teach-In operation is aborted before the green LED go out
 - ➔ The supply voltage has been disconnected during the Teach-In operation

Teach-In function for a new actuator:

1. Apply the operating voltage to the evaluation unit
2. Move the new actuator towards the read head (note distance < S_{ao})
 - ➔ Teach-In operation commences; green LED blinks (approx. 1 Hz)
3. Teach-In operation complete (after 60 seconds)
 - ➔ Green LED goes out, new code is saved and old code is deactivated.

Important:

The system automatically reverts to Teach-In mode even after the 8th Teach-In operation or if an "old" actuator is moved against the read head. In both cases, a Teach-In operation lasting 60 seconds is initiated but the last actuator code remains active in memory (see Status table); no new code is taught.

System status table

	Actuator/ Door position	Relays KA, KB (Safety circuit)	PLC			LED Indicator				Status
			Input		Output	STATE (green)	Number of blink pulses	OUT (yellow)	ERR (red)	
			TST	OUT (alarm signal)	ERR					
Normal operation	closed	on	N	1	0	1		1	0	Normal operation, door closed
	open	off	N	0	0	1		0	0	Normal operation, door open
Commissioning	open	off	N	0	0	blinks constantly at 4 Hz		0	0	Initial commissioning on delivery Ready for first Teach-In operation
	closed	off	N	0	0	blinks 60 sec at approx. 1 Hz		0	0	Teach-In operation
	closed	off	N	0	0	closed		0	0	Positive acknowledgement for successful Teach-In operation. The unit must be switched back on again for normal operation
Status display	X	off	X	0	0	One-Off blink sequence after power-off	3	0	0	Indication after 1st to 5th Teach-In operation
	X	off	X	0	0		2	0	0	Indication of the number of Teach-In operations still allowed after the 6th Teach-In operation
	X	off	X	0	0		1	0	0	Indication of the number of Teach-In operations still allowed after the 7th Teach-In operation
	X	off	X	0	0		0	0	0	Device is now unable to perform a further Teach-In operation
Error indication	X	off	N	0	1	0		0	1	Device-internal component failure
	X	off	N	0	1	0		0	1	Actuator in response range less than 0.5 sec
Operating error	closed	off	N	0	1	Brief blink sequences repeated after 1 sec	1	0	1	Illegal 9th Teach-In operation
	closed	off	N	0	1		2	0	1	Illegal Teach-In operation of an old actuator
	closed	off	N	0	1		3	0	1	Negative acknowledgement for Teach-In operation. Actuator
Test mode	open	off	1	0	1	1		0	1	
	closed	off	1	0	1	1		0	1	External device test for „OPEN“ and function ERR output with door closed

N = 0 Volt or not connected
 0 = 0 Volt
 1 = 24 Volt
 X = 0 or 24 Volt resp. door open or closed

1 = on
0 = off

Ordering table for T 4000

Non-contact Safety Interlocks

Type	Part number
Actuating key T 4000-1 KBA	5 306 531

Type Detector	Cable Length			Part number
	5 m	10 m	15 m	
T 4000-1 DNA	05 P			6 012 144
T 4000-1 DNA		10 P		6 012 145
T 4000-1 DNA			15 P	6 012 146

Further cable lengths on request

Type	Part number
Relay Box T 4000-1 RBA 01	6 012 147

E 100 Enabling Switch

Switch for carrying out programming, set-up or commissioning work.

Use

When these switches are used as hand-operated command units they allow work to be carried out within the hazardous zones of machines and plant.



Enabling Switch

General

Enabling switches are manually operated control devices which are intended for use by persons working in danger areas of machines and installations.

In "Manual mode", the protective effect of movable safety guards may be disabled under certain conditions.

Authorized personnel can then enter dangerous areas with the enabling switch, subject to observance of certain preconditions, in order to perform programming, setup work, testing or service work, for example.

Enabling switches can perform their task properly only if safe handling is possible for long periods, e.g. during observation of production sequences, without the operator becoming tired.

Besides an absolute safe function we put specific attention to a perfect and balanced ergonomics of the SICK enabling switches, in order to being able offering a product which can be operated pleasantly in order to reduce readiness for manipulation.

Design

All SICK enabling switches have a robust plastic housing offering a high degree of protection. The fully-developed design is characterized by the following features:

- perfect ergonomics
- light weight
- easily switched from hand to hand
- light and stable action point
- redundant make circuits
- reliable line monitoring for cross shorts
- tamper resistant

SICK Enabling switches are available in

- different hand versions and
- different built-in versions

each with different switching element configurations in each case.

The hand versions are available with three different cable types, namely 5 m or 10 m straight cable or 5 m coiled cable, and also as a kit.

The patented cables of the enabling switches possess individually shielded conductors to permit effective cross-short monitoring. The shields must be connected with the PE system of the machine or installation.

If the cables are then crushed, for example, short circuits will be detected and the control switched off immediately by tripping of the short-circuit protective device. This eliminates the need for an additional evaluation device for line monitoring.

Function

The functional sequence of SICK enabling switches meets the requirements for 2-stage and 3-stage enabling switches in accordance with **EN 775** and **VDI 2854**.

Functional sequence of 3-stage enabling switches:

- Stage 1:** **OFF function**
(actuating element not pressed)
- Stage 2:** **Enabling function**
(actuating element pressed to center position)
- Stage 3:** **OFF function with positive opening operation**
(actuating element pressed down fully past the center position)

A patented switch mechanism prevents the enabling function from being activated when the switch returns from stage 3 to stage 1.

The exact functional sequence is shown in the switching diagrams of the respective enabling switches.

Application

Enabling switches are used in automated production installations, for example, which are operated in "Manual mode" in accordance with the regulation EN775 and VDI 2854. This operating mode must be defined by means of lockable selector switches as stipulated in EN 60204 T1 (DIN VDE 0113 T1).

Safety guards are partially disabled in this mode. For this reason, the person working in the dangerous area with the enabling switch must be able to recognize dangerous conditions in good time and initiate corresponding counter-measures.

Important:

Commands for dangerous operations must not be initiated with the enabling switch alone. A "second, conscious" start instruction is necessary for this purpose. Each person to be in the dangerous area has to have an own Enabling Switch.

Approvals

SICK enabling switches have the following approvals:

BIA, Germany
SUVA, Switzerland
SAQ, Sweden

as well as approval by the automotive industry.

Enabling Switch

E 100 (3-stage / dual channel)

Dimensional drawing

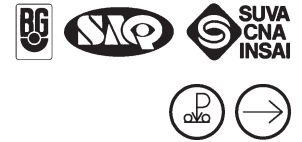
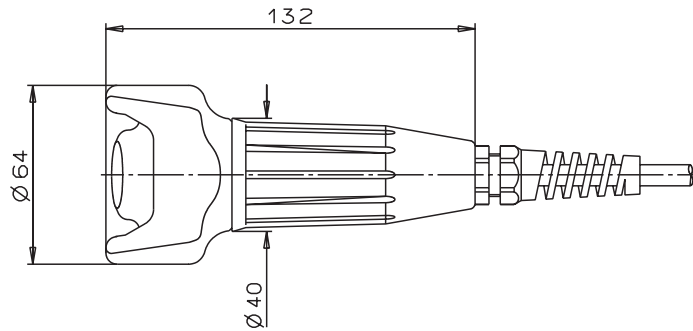

Technical data

Parameter	Value	Unit
Housing material	Plastic	
Environmental protection to IEC 529	IP 67	
Ambient temperature	- 5 to + 60	°C
Switching elements	see ordering table version IV and V	
Switching principle	Slow-action Switch	
Utilization category to IEC 947-5-1	AC-15 U _e 230 V I _e 4 A / DC-13 U _e 24 V I _e 3 A	
Connection	cabl 8 x 0.34 mm ²	
Fuse	F 6	A
Weight	approx. 1.1	kg

Wiring diagram/ Switching diagram

2 NO
2 pos. driven NC

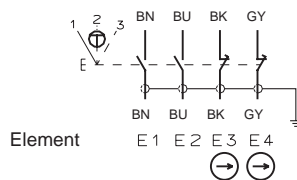

Element

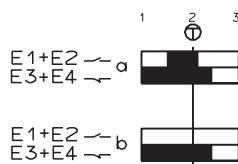
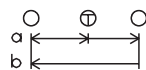

⊕ Positively driven NC

⊕ Trigger point

Element

Contact
□ open
■ closed

Fixing bracket for type E 100

Material: Aluminium coated
Height: 30 mm

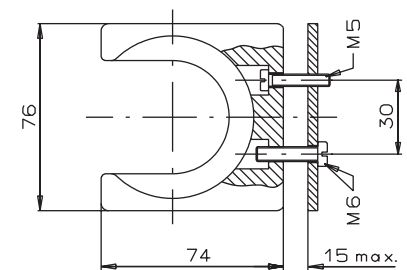

Ordering table E 100

Enabling Switch

Type	Design Type standard	Stage Model 3-stage	Internal Connection single	Dual Pole Switch 2 N.O. contacts	Cable Type straight	Cable Length 5 m	Connector without	Part number
E 100-	A	2	A	4	S	05	A	6 012 141

Other versions: on request

Ordering table

Fixing bracket, aluminium

Type	Part number
Aluminium	5 308 209

Regulations and Standards

A guide to the relevant regulations and standards.

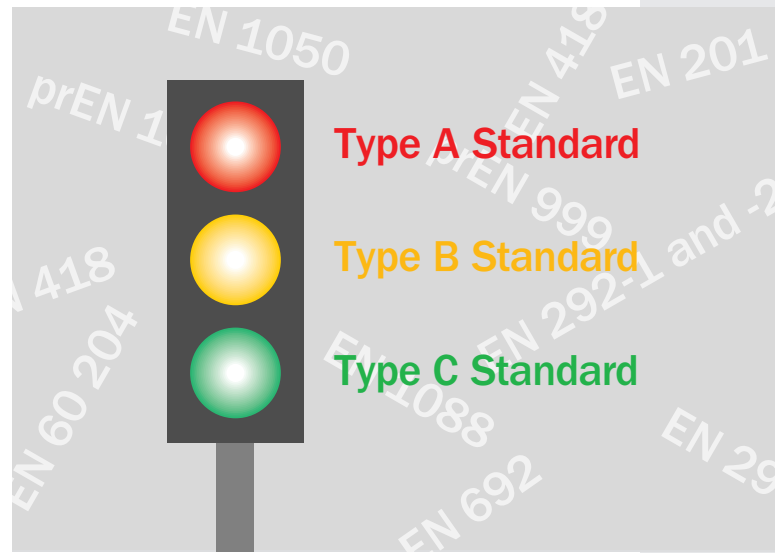

Risk Analysis – Control Categories

Safety consideration for safety guards

Monitoring of movable safety guards includes the devices for position monitoring and for signal processing in the control system.

Signal processing of the safety circuits must be integrated in the overall control system so that this cannot be rendered ineffective by other control elements.

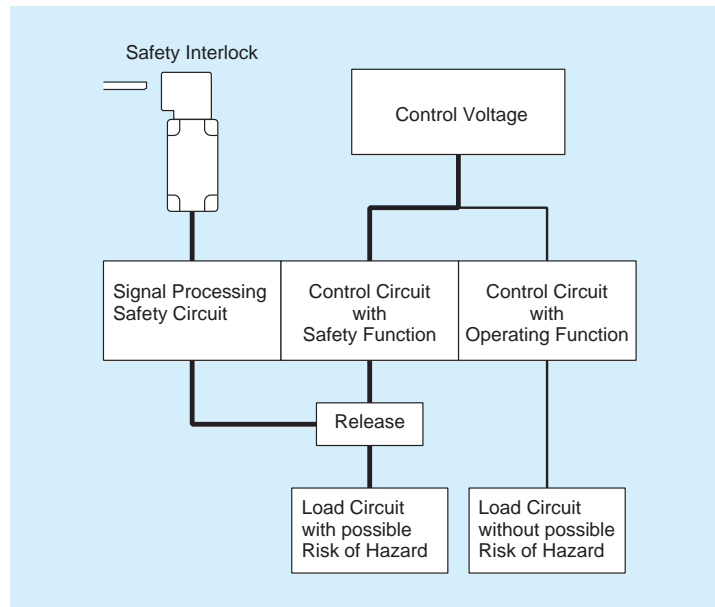

Design of a machine control system

Safety circuits may carry out an operational function, but must primarily perform safety tasks and be able to directly intervene in load circuits where there is potential danger.

Safety guards and their monitoring and signal processing systems have to satisfy variously high requirements, depending

on the degree of potential danger to persons and machines. Possible realization forms extend from a simple mechanical-action position interlock to a self-monitoring locking mechanism with start-up testing. The requirement level which should be satisfied in an individual case can be determined in a risk analysis that takes into account the danger parameters.

Risk Analysis – Control Categories

Risk estimation according to EN 954-1

The method described in this standard permits the risk involved in a particular application to be estimated on the basis of a few parameters which are characteristic for the risk.

This risk analysis allows determination of a so-called requirement class from a predefined classification scheme.

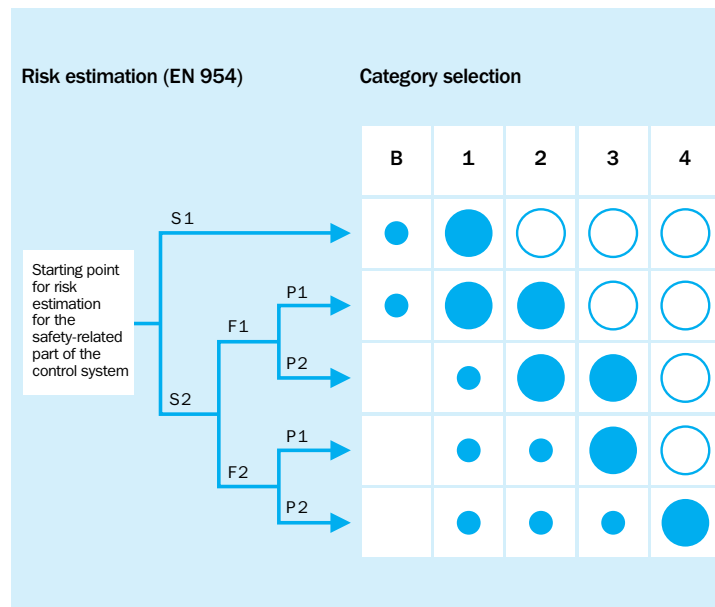

Risk estimation in case of faults in the safety related parts of the control system and selection of an appropriate category

S – Severity of injury

- S1 – Slight (normally reversible) injury
- S2 – Serious (normally irreversible) injury including death

F - Frequency and/or exposure time to the hazard

- F1 – Seldom to quite often and/or the exposure time is short
- F2 – Frequent to continuous and/or the exposure time is long

P – Possibility of avoiding the hazard

- P1 – Possible under specific conditions
- P2 – Scarcely possible

B, 1–4 Categories for safety-related parts of control systems

- Preferred categories for reference points
- Possible categories which can require additional measures
- Measures which can be over dimensioned for the relevant risk

Control Categories

Categories of safety-related Control Systems according to EN 954-1

Category ²⁾	Summary of requirements	System behaviour ¹⁾	Main principle to achieve safety
B	Safety related parts of machine control systems and/or their protective equipment, as well as their components, shall be designed, constructed, selected, assembled and combined in accordance with the state of the art so they can withstand the expected influence.	The occurrence of a fault can lead to the loss of the safety function.	Mainly characterized by selection of components
1	Requirements of B shall apply. Well-tried components and well-tried safety principles shall be used.	The occurrence of a fault can lead to the loss of the safety function but the probability of occurrence is lower than for category B.	
2	Requirements of B and the use of well-tried safety principles shall apply. Safety function shall be checked at suitable intervals by the machine control system.	<ul style="list-style-type: none"> • The occurrence of a fault can lead to the loss of the safety function between the checks. • The loss of safety function is detected by the check. 	Mainly characterized by structure
3	Requirements of B and the use of well-tried safety principles shall apply. Safety-related parts shall be designed, so that: <ul style="list-style-type: none"> • a single fault in any of these parts does not lead to the loss of the safety function; and • whenever reasonably practicable the single fault is detected. 	<ul style="list-style-type: none"> • When single fault occurs the safety function is always performed. • Some but not all faults will be detected. • Accumulation of undetected faults can lead to the loss of the safety function. 	
4	Requirements of B and the use of well-tried safety principles shall apply. Safety-related parts shall be designed, so that: <ul style="list-style-type: none"> • a single fault in any of these parts does not lead to the loss of the safety function; and • the single fault is detected at or before the next demand upon the safety function. If this is not possible, then an accumulation of faults shall not lead to a loss of the safety function. 	<ul style="list-style-type: none"> • When faults occur the safety function is always performed. • The faults will be detected in time to prevent the loss of the safety function. 	

¹⁾ The categories are not intended to be used in any given order or in any given hierarchy in respect of safety requirements.

²⁾ The risk assessment will indicate whether the total or partial loss of the safety function(s) arising from faults is acceptable.

Regulations – Standards – Recommendations

Standard / Regulation	Description
IEC 204-1 EN 60204 Part 1 DIN VDE 0113	Electrical equipment of industrial machines General requirements
IEC 947-5-1 EN 60947 DIN VDE 0660 200	Low voltage, switchgear and controlgear/position switches with positive opening operation
EN 775	Safety requirements for construction, equipment and operation of robot systems
VDI 2854	Safety requirements for automated manufacturing systems
EN 292-1 EN 292-2	Safety machines, basic terms, general design principles and specifications
EN 954	Safety of machines Safety related parts of control systems Part 1: General design
EN 1050	Safety of machines, risk assessment
EN 1088	Interlocking devices with and without guard locking
BIA-Report 3/89	Configuration and analysis of electromechanical safety circuits for position monitoring of movable safety guards
ZH 1/153 Reference sheet 2/96 Employers' Liability Insurance Association for Precision Mechanics and Electrical engineering	Selection and installation of electromechanical locking facilities. Reference sheet for selection and attachment of electromechanical locking devices for safety functions.

Source	Contact
Laws and ordinances	Available in bookshops or from Carl Heymanns-Verlag KG, Luxemburger Str. 449, D-50939 Köln 41 Phone: +49 221/46 01 00, Fax: +49 221/46 01 69
Accident prevention regulations (VGB number) as well as directives, safety regulations, principles, codes of practice (ZH 1/number)	Carl Heymanns-Verlag KG Address see above
DIN-standards and VDMA standard sheets	Beuth-Verlag GmbH, Burggrafenstr. 6, D-10787 Berlin Phone: +49 30/2601-1, Fax: +49 30/2601-231
VDE-regulations	VDE-Verlag GmbH, Bismarckstr. 33, 10625 Berlin Tel.: 030/348001-0
BIA-Report	Berufsgenossenschaftliches Institut für Arbeitssicherheit – BIA Alte Heerstraße 111, Postfach 20 43, D-53754 St. Augustin 2 Phone: (+49 22 41) 2 31-02

Regulations – Standards – Recommendations

Standard / Regulation	Description
United States Regulations/Standards	Definition of a Safety System
OSHA 1910...	Control Reliability
ANSI B 11...	Single Component Failure
ANSI/RIA R 15.06-1992	

Source	Contact
ANSI Standards	American National Standards Institute 11 West 42nd St. New York, NY 10036 Phone: 212-642-4900
Government and industry regulations, specifications and standards, ANSI, BS, IEC, ISO, VDE, DIN	Global Engineering Documents 15 Inverness Way East Englewood, CO 80112-5704 Phone: 303-792-2181/800-854-7179 Fax: 303-397-7935
Code of Federal Regulations (CFR)	Occupational Safety & Health Administration Phone: 212-264-3825

Colour Code Table

Code for colour marking according IEC 757

Colour	Abbreviation old	Abbreviation new
Black	sw	BK
Brown	br	BN
Red	rt	RD
Orange	or	OG
Yellow	ge	YE
Green	gn	GN
Blue	bl	BU
Violet	vi	VT
Grey	gr	GY
White	ws	WH
Pink	rs	PK
Gold	–	GD
Turquoise	tk	TQ
Silver	–	SR
Green-Yellow	gnge	GNYE

Definition of terms

Safety Interlock categories

Safety Interlocks are divided into two different categories.

Interlocks category 1

Interlocks where the switching element and actuator form a unit.

Interlocks category 2

Interlocks where the switching element and actuator do not form a design unit, but are functionally combined or separated during actuation. (See page 102 for other designs).

Automatic mode

Automatic mode is an operating mode where, in contrast to manual mode, only system start-up is initiated by human intervention. All further sequences are executed automatically.

Dangerous conditions

These conditions which may lead to injuries. Safety interlocks eliminate this risk in conjunction with proper use of the safety guard.

Manipulation

Manipulation is the intended deactivation or defeating of safety guards and their components. Safety interlocks and guards must be designed so that the safety functions cannot be changed or bypassed by hand or by using a simple tool. Simple tools include screwdrivers, ballpoint pens, nails, pieces of wire, adhesive tape, etc.

Simple tools do not include items which have to be produced using tools in more than one operation. Dismantling of parts, turning the safety interlock from its protective position, use of a second actuator or bridging of contacts do not fall into the category of bypassing in a simple manner. Wilful and intended deactivation of safety guards is always treated as a grossly negligent act with corresponding consequences in the event of accidents. At the design stage, it should be remembered that simple and proper operation of machines and installation must remain possible in spite of the safety guards. If this fact is forgotten, this may lead to safety measures being bypassed.

Installation

The mounting location and installation method of safety interlocks are decisive criteria in ensuring reliable monitoring of safety guards and their functioning with respect to general operating safety. Safety guards and their components such as safety interlocks must be viewed in direct relation to their possible manipulation. Design precautions should therefore be taken to practically eliminate these possibilities. Equally important to observance of general rules and regulations, e.g. form-fit assembly of all safety components in safety guards, a further reduction in risk can also be achieved by implementation of preventive design measures.

- Mounting of safety interlocks behind the safety guards or inside the installation.
- Locking out of the actuator entry opening of the safety interlock (category 2) when the safety guard is open (see lockout bar, page 59/77).
- Assembly location of the interlock actuator in a so-called C-rail to prevent the use of a "second" actuator.

Standards

Certain regulations, standards, directives and recommendations must be observed when designing safety devices and their components.

Risk analysis

It is necessary to carry out a risk analysis in order to determine the safety objectives and the corresponding measures required. The required safety solutions are defined by taking into account the risk parameters and the degree of danger. (See chapter "Norms and Standards" for further information).

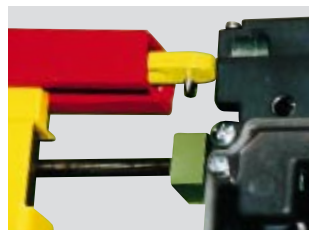

Manipulation protection by means of a C-rail

Switching elements

The switching elements of safety interlocks must possess positive actuators. The switching elements for the safety function must be positively driven or, in the case of snap-action switching elements, guarantee reliable opening of the NC contact when the positive opening point is reached.

A distinction is made between the following switching element types corresponding to their switching behaviour:

- **Slow-action contact element**
Contact element which opens or closes dependent on the speed of its actuation.
- **Snap-action contact element**
Contact element which opens or closes independently of the speed of its actuation.
(See page 100 for further information).

Safety guards

A basic distinction is made between fixed and movable safety guards. Fixed safety guards are used at dangerous locations where it is not necessary to intervene or where intervention is necessary only on rare occasions. These guards are normally permanent and can be removed only by means of tools. Movable safety guards are used wherever it is necessary to reach into the dangerous location for the purpose of machine operation, fault rectification or during set-up mode. These guards are monitored by means of safety interlocks.

Safety interlocks

Safety interlocks are safety devices which are used to monitor movable safety guards. They must reliably interrupt the circuit when the guard in question is opened and keep the circuit open until the guard is closed again. Safety interlocks with solenoid interlock are locking devices which act in conjunction with the control to keep movable safety guards in their safety position until dangerous conditions no longer exist.

Cycle operation

This involves manual intervention at dangerous locations during the working cycle of the machine. Here, the safety measures must guarantee a high safety level in monitoring of the safety guard and in signal processing. If these conditions are satisfied, the start command can be issued in this mode after proper return of the safety guard to its protective position.

Enabling switches

These are manually-operated control devices which are designed for working in the danger areas of machines and installations.

The protective effect of movable safety guards is deactivated under certain conditions when working in "Manual" mode. Authorized personnel can enter danger zones with the enabling switch to perform programming set-up, observation, repair, test or service work.

(For further information, refer to page 88, Chapter "Enabling switches").

Positive opening

Positive opening for safety interlocks means that there must be positive force transmission between the actuator and switching element. The actuation mechanism must be designed so that the contact point opens reliably and remains open in activated condition even in the event of mechanical failure, e.g. breakage of a spring or contact welding. Further regulations are defined in the standard IEC 947-5-1, EN 60947, VDE 0660, part 200.



SICK Safety Interlocks marked with this symbol indicate N/C interlocks with positively driven contacts. This also meets the requirements of IEC 947-5-1.



SICK Safety Interlocks marked with this symbol meet the requirements according to GS-ET-15 and GS-ET-19.

These interlocks fulfill higher requirements than interlocks with the -symbol.

Switching Elements

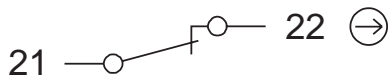

Switching element ES 508¹⁾

Slow-action contact element with one positively driven NC contact.
Double-break feature, contact material: silver alloy, gold-flashed screw terminal with spring-loaded clamping washers.

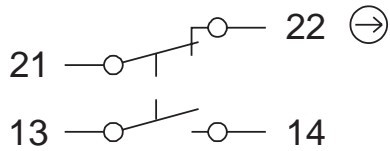

Switching element ES 511²⁾

Snap-action contact element with one positively driven NC contact and one NO contact.
Double-break feature, electrically separated contact elements, contact material: silver alloy, gold-flashed, screw terminal with spring-loaded clamping washers.
Suitable for i100.

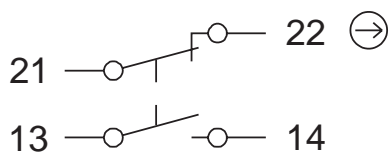

Switching element ES 514²⁾

Magnetic snap-action contact element with one positively driven NC contact and one NO contact.
Double-break feature, electrically separated contact elements, contact material: fine silver, screw terminal with spring-loaded clamping washers.

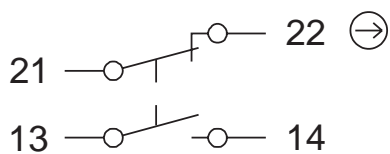

Switching element ES 528¹⁾

Slow-action contact element with one positively driven NC contact and one NO contact.
Double-break feature, electrically separated contact elements, contact material: silver alloy, gold flashed, screw terminal with spring-loaded clamping washers.
Suitable for i100 Series.

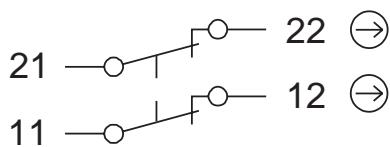

Switching element ES 538¹⁾

Slow-action contact element with two positively driven NC contacts.
Double-break feature, electrically separated contact elements, contact material: silver alloy, gold-flashed, screw terminal with spring-loaded clamping washers.
Suitable for i100 Series.

Note

Switching elements of safety interlocks must not be replaced.

¹⁾ Slow-action switch

A slow-action switch possesses a contact element which opens and closes dependent on the actuation speed.

²⁾ Snap-action switch

A snap-action switch possesses a contact element which opens or closes independently of its actuation speed.

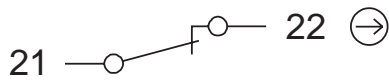

Switching element ES 588

Slow-action contact element with one positively driven NC contact.
Double-break feature, contact material: silver alloy, screw terminal.

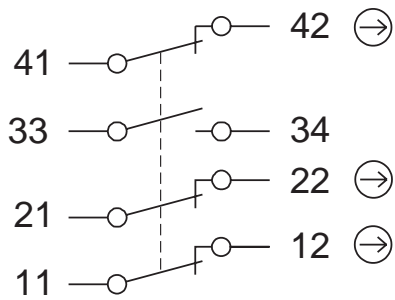

Switching element SK 2131

Slow-action contact element with three positively driven NC contact and one NO contact.
Double-break feature, electrically separated contact elements, contact material: silver alloy, gold-flashed, screw terminal with spring-loaded clamping washers.
Suitable for i100/i10 Series.

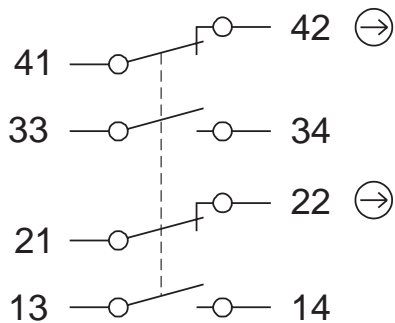

Switching element SK 3131 or ÜK 3131

Slow-action contact element with two positively driven NC contact and two NO contact.
Double-break feature, electrically separated contact elements, contact material: silver alloy, gold-flashed, screw terminal with spring-loaded clamping washers.
Suitable for i100/i10 Series.

Safety Interlocks are divided into two functionally different categories corresponding to the definition of the German Employers' Liability Insurance Association.

Interlocks Category 1

Interlocks where the switching element and actuator form one constructional and functional unit.

Functional characteristic:

Safety function when the interlock actuator is moved.

Interlocks Category 2

Interlocks where the contact element and actuator do not form a constructional unit, but are functionally combined or separated during actuation.

Functional characteristic:

Safety function when the actuator is removed from the interlock.

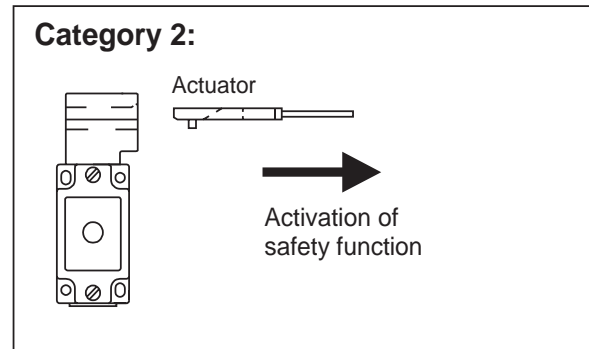
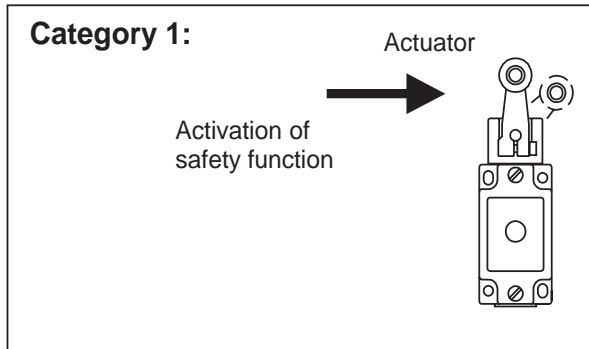

This distinction results in basic design criteria for safety interlocks applications.

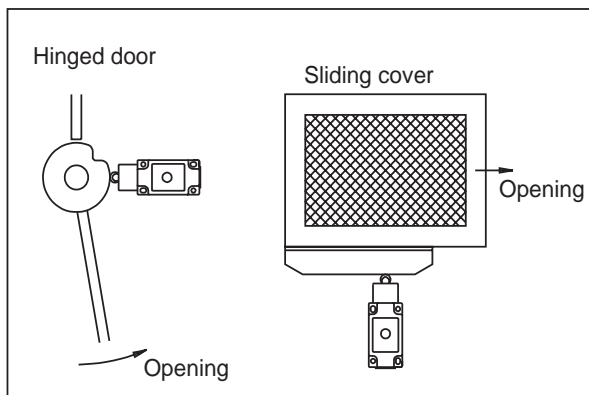

Installation example for interlocks of the category 1

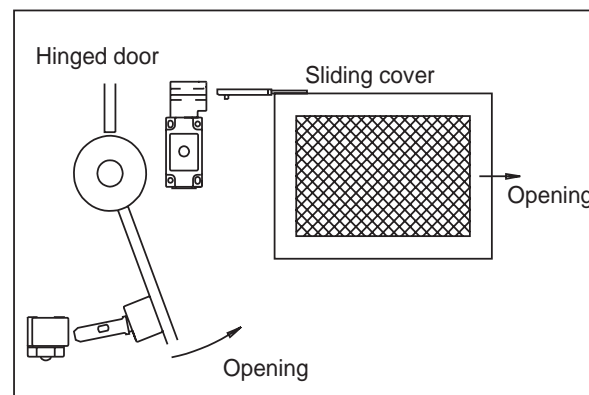

Installation example for interlocks of the category 2

Application

- safety limit interlocks and proximity interlocks with trip dogs,
- hinged door monitoring with cam plate actuation,
- sliding covers and protective screens with trip dogs or for monitoring of protective covers which have to be opened during operation with two safety interlocks and safety relay or corresponding relay or contactor control.

Application

Safety interlock without locking

- in case with only rare or occasional intervention at dangerous locations, e.g. service covers, flaps, lift-out covers etc.

Safety interlock with locking

- protective covers and guards for opening during operation in cases with dangerous machine run-down movements or continuing dangerous conditions.