



Proximity Laser Scanner PLS

SICK



Reg. No. 19462-2

Table of Contents

1	Approvals and Certificates	4	9.11	Interrogate fault memory (system diagnosis)	57
2	Notices / Regulation Use	6		Initial fault diagnosis.....	57
3	How the PLS Works	7		Interrogate PLS fault memory	57
	Principle of function	7	10	Care and Maintenance	59
	Fields and measuring range of the PLS	8	10.1	SICK Service / Hotline	59
4	Fields of Application – What the PLS Can Do	9	10.2	LEDs on the PLS	60
	Area protection	9	10.3	PLS fault table	61
	Internal space protection	9	10.4	Service questionnaire	62
	Vehicle protection and navigation	10	11	Appendix	64
	Measurement of contours	10	11.1	Characteristics	64
5	Location Planning	11	11.2	Accessories	65
	Range of the PLS	11		PLS variants	65
5.1	Stationary protection with PLS	12		Mounting kits	65
	Important notes on configuration	12		Connection set	65
	Location planning	13		Interface cables	65
	Restart definition	16		Documentation and user software	65
	Mounting recommendations for PLS	16		Other SICK accessories	65
5.2	Mobile protection with PLS	19		And also	65
	Location planning	20	11.3	Technical data	66
	Calculation of the necessary protective field	21	11.4	Standards and regulations	67
	Configuration examples	22	12	Glossar	71
5.3	If you use several PLS units	23			
6	Supply Package	24			
	Recommended accessories	24			
	Connection set	24			
	Interface cable	24			
7	Mounting the PLS	25			
8	Connecting Up the PLS	28			
	Connecting the power connector	29			
	Connection examples	29			
	Notes	33			
	Connecting the interface connector	34			
	Short-term connection to a PC	35			
	Permanent connection to an evaluation computer ...	35			
9	Programming the PLS with the User Software	36			
9.1	Installing the user software	36			
	System requirements	36			
9.2	What to do	37			
	Essential steps	37			
	Other options	37			
9.3	Entry: The initial configuration	38			
	Configure hardware	39			
	Send configuration to PLS	42			
	Edit monitoring range	43			
	Send monitoring range to PLS	46			
9.4	Edit/dimension fields	47			
	Convert fields	47			
	Change scale of segmented field	47			
	Copy and paste fields	48			
	Save individual fields	48			
	Fix coordinates	48			
9.5	Teach-in protective field	49			
9.6	Monitor protective field	51			
9.7	Check settings	52			
9.8	Receive and store configuration	53			
9.9	Change password	54			
9.10	Change screen view	55			

This technical description contains all the information necessary for project planning and setting up the PLS. You will find in it the information you need for mechanical mounting, electrical installation and programming of the PLS.

The description covers the following PLS types:

- PLS 101-312
- PLS 101-112 and PLS 101-212
- PLS 201-113, PLS 201-213 and PLS 201-313

Along with the technical description you are also provided with an instruction manual, containing important information for day-to-day use of the PLS.

Keep the technical description and the instruction manual readily to hand at all times.

Essential sections you should read:

Important notes	Section 2
Location planning	Section 5
Supply package, Mounting and connecting up the PLS:	Sections 6 to 9
Entry into the user software.....	Sections 9.1 to 9.3

1 Approvals and Certificates

EC Declaration of Conformity

Under the terms of EC Machine Directive 89/392/EEC, Appendix II C

We hereby declare that the devices (see page 2)

of the product family PLS101-312



are safety components for a machine constructed as per the EC directive 89/392/EEC art. 1 para. 2. This declaration will lose its validity if any modification to a device used in the plant is made without prior consultation.

We employ a quality system certified by the DQS (German Quality Assurance Society), No. 19 462-01, as per ISO 9001 and have therefore observed the regulations in accordance with module H as well as the following EC directives and EN standards during development and production:

- | | | | |
|---|---|---|-----------|
| 1. <i>EC directives</i> | EC machine directive 89/392/EEC, as per 91/368/EEC, 93/68/EEC, 93/44/EEC
EC EMC directive 89/336/EEC as per 92/31/EEC, 93/68/EEC, 93/465/EEC | | |
| 2. <i>Harmonized standards and preliminary standards used</i> | DIN EN 954-1 | Safety-related components of controllers | Ed. 97-03 |
| | EN 50082-2 | Immunity, indust. | Ed. 96-02 |
| | EN 50081-2 | Emitted interference, indust. | Ed. 94-03 |
| | IEC 61496-1 | Safety of mach., active opto-electronic protective devices (AOPD) | Ed. 97-12 |
| | DIN V VDE 0801 | Basic principles for computers in systems with safety functions | Ed. 90-01 |
| | DIN V VDE 0801/A1 | | Ed. 94-10 |
| 3. <i>Test result</i> | DIN 40839 T1 | Electromagnetic compatibility in road vehicles | Ed. 92-10 |
| | DIN 40839 T3 (Entw.) | Electromagnetic compatibility in road vehicles | Ed. 91-12 |
| | IEC 61496-1 | BWS type 3 (BWS-E) | |

Conformance of a type sample belonging to the above-mentioned product family with the regulations from the EC machine directive has been certified by:

Address of notified authority (Germany) Berufsgenossenschaftliches Institut für Arbeitssicherheit (BIA)
Alte Heerstr. 111
D-53757 Sankt Augustin

EC type sample test No. 981068 dated 1998-04-17

The CE mark was affixed to the appliance in conformance with directive 89/336/EEC.

Waldkirch/Br., 1998-04-20

ppa. Windau
(Head of Sales & Marketing
Division Safety Systems)

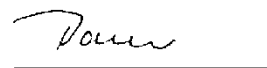
ppa. Dr. Bauer
(Head of Development)

The declaration certifies conformance with the listed directives, but does not guarantee product characteristics. The safety instructions contained in the product documentation must be observed.

Mat. No.: 9 051 785

Page 3, engl.

Update no.: see page 2

SICK AG
Sebastian-Kneipp-Str. 1
D-79183 Waldkirch

Telefon (0 76 81) 202-0
Telex 772314
Telefax (0 76 81) 38 53

Aufsichtsratsvorsitzender:
Dr. Horst Skoludek
Vorstand:
Volker Reiche (Vors.)
Anne-Kathrin Deutrich
Dieter Fischer

Sitz: Waldkirch i.Br.
Handelsregister
Emmendingen HRB 355 W

EC Declaration of Conformity

Under the terms of EC Machine Directive 89/392/EEC, Appendix II C

We hereby declare that the devices (see page 2)

of the product family PLS10.-1.. , PLS10.-2..



are safety components for a machine constructed as per the EC directive 89/392/EEC art. 1 para. 2. This declaration will lose its validity if any modification to a device used in the plant is made without prior consultation.

We employ a quality system certified by the DQS (German Quality Assurance Society), No. 19 462-01, as per ISO 9001 and have therefore observed the regulations in accordance with module H as well as the following EC directives and EN standards during development and production:

1. EC directives	EC machine directive 89/392/EEC, as per 91/368/EEC, 93/68/EEC, 93/44/EEC EC EMC directive 89/336/EEC as per 92/31/EEC, 93/68/EEC, 93/465/EEC		
2. Harmonized standards and preliminary standards used	pr EN 954-1	Safety-related components of controllers	Ed. 94-11
	EN 50082-2	Immunity, indust.	Ed. 96-02
	EN 50081-2	Emitted interference, indust.	Ed. 94-03
	pr EN 50100-1	Safety of mach., active opto-electronic protective devices (AOPD)	Ed. 94-05
	DIN V VDE 0801	Basic principles for computers in systems with safety functions	Ed. 90-01
	DIN V VDE 0801/A1		Ed. 94-10
	DIN 40839 T1	Electromagnetic compatibility in road vehicles	Ed. 92-10
	DIN 40839 T3 (Entw.)	Electromagnetic compatibility in road vehicles	Ed. 91-12
3. Test result	DIN V VDE 0801	Requirements Class 4	Ed. 90-01
	pr EN 954-1	BWS type 3 (BWS-E)	Ed. 94-11

Conformance of a type sample belonging to the above-mentioned product family with the regulations from the EC machine directive has been certified by:

Address of notified authority (Germany) Berufsgenossenschaftliches Institut für Arbeitssicherheit (BIA)
Alte Heerstr. 111
D-53757 Sankt Augustin

EC type sample test No. 961077 dated 1996-04-29

The CE mark was affixed to the appliance in conformance with directive 89/336/EEC.

Waldkirch/Br., 1996-07-27

i. V., Windau
(Head of Sales & Marketing
Division Safety Systems)

i. V., Zinober
(Head of Production
Division Safety Systems)

The declaration certifies conformance with the listed directives, but does not guarantee product characteristics. The safety instructions contained in the product documentation must be observed.

Mat. No.: 9 044 438
Page 3, engl.

Update no.: see page 2

Erwin Sick GmbH
Optik-Elektronik
Sebastian-Kneipp-Str. 1
D-79183 Waldkirch

Telefon (0 75 81) 202-0
Telex 772314
Telefax (0 75 81) 38 63

Geschäftsführung:
Volker Reiche (Vors.)
Dieter Fischer
Anne-Kathrin Deutrich

Sitz: Waldkirch i.Br.
Handelsregister
Emmendingen HRB 55 WK

2 Notices / Regulation Use

The PLS proximity laser scanner is a device designed to protect people and property. It is intended to monitor hazardous areas in enclosed spaces. PLS is not designed for outdoor use. Observe the instructions relating to regulation use. SICK cannot be held liable for damage arising from use of the PLS other than stipulated.

- Install the PLS in a dry location and protect the unit against dirt and damage.
- Lay all wires and connecting cables such that they are protected against damage.
- Make sure that no obstacles in the monitoring range can obstruct the field of vision of the PLS or cause shadows. Such shadow areas cannot be monitored by the PLS. Where there are unavoidable areas of shadow, check whether they present any risk. Take additional precautionary measures as necessary.
- Keep the monitoring range free of smoke, fog, steam and other air pollution. The functioning of the PLS may otherwise be impaired and error shutdowns may occur.
- Avoid placing strongly reflective objects such as retroreflectors in the scanning plane of the PLS, as they may influence its measurement results.
- Mount the PLS so that it cannot be dazzled by sunlight. Also avoid stroboscopic and fluorescent lamps, as they may influence the PLS under certain circumstances.
- In mounting, installation and use of the PLS, observe the standards and regulations applicable in your country. The Appendix presents a summary of the most important regulations.
- For programming of the monitoring range, take note of the description of the user software as from section 9. This describes how to connect the PLS to a PC and how to work with the user software.
- Before releasing the machine for use, test whether access to the hazardous area is fully covered by the safety devices. After release, also check at regular intervals (such as every morning before beginning work) that the PLS is activated properly when an intrusion into the protective field occurs. This test should be carried out along all protective field limits, in accordance with application-specific regulations.
- If you want to deploy one or more PLS together with a LSI (Laser Scanner Interface) in your application, to work with several different switchable or variable protective fields for example, please also take note of the technical description of the LSI.
- The PLS must be disposed of in a proper and environmentally friendly manner at the end of its useful service life.

3 How the PLS Works

Principle of function

The PLS is an optical sensor which scans its surroundings with infrared laser beams. It is used to monitor a hazardous area on a machine or vehicle. The PLS can be used on manually controlled vehicles, such as narrow-aisle forklifts and other lift trucks, as well as in driverless transport systems (DTS) such as shunting cars and free-navigating vehicles.

As a result of its scanning principle, the PLS requires neither separate receivers nor reflectors.

This has the following advantages:

- You can adapt the monitoring range precisely to the hazardous area of a machine.
- Since you do not need any receivers or additional reflectors, you keep the entire area freely accessible and driveable.
- If the hazardous area changes you can alter the sensor simply by reprogramming the software, with no additional mounting.
- Different reflective materials do not influence the functioning of the sensor. This makes the PLS highly versatile in its uses.

The sensor operates on the principle of reflex light time measurement. It emits very short light pulses. At the same time an "electronic stopwatch" runs. If the light encounters an object, it is reflected and thrown back to the sensor. From the time between sending and receiving, the sensor calculates its **distance** from the object.

In the sensor there is also a uniformly rotating mirror which deflects the light pulses such that they sweep a semicircular area. By determining the mirror angle, the PLS detects in which **direction** the object is located.

From the measured distance and the direction of the object the sensor determines its precise **position**.

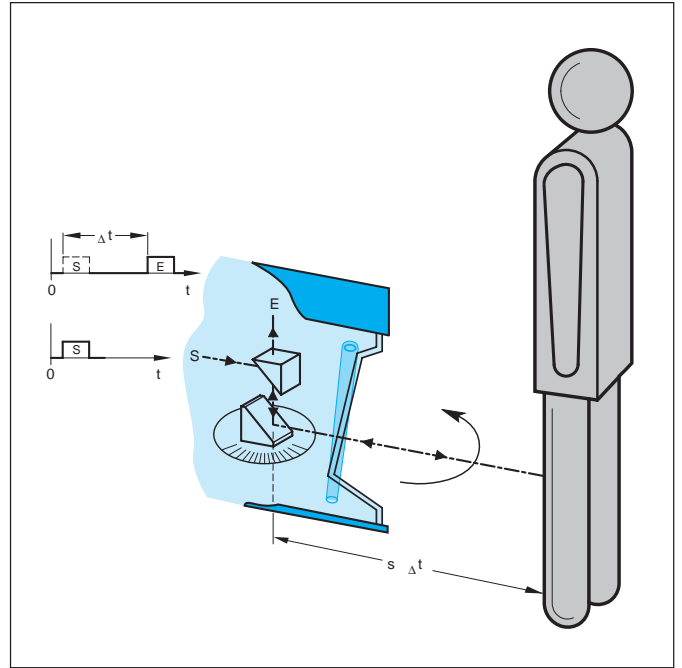

Fields and measuring range of the PLS

The monitoring range of the sensor consists of a protective field and a warning field. You can use the supplied software to define the two fields and store them in the memory.

The **protective field** protects the hazardous area of a machine or vehicle. As soon as the sensor detects an object in the protective field, it shuts down the machine or stops the vehicle immediately.

This is a safety function. Its safety integrity corresponds to cat. 3 to EN 954-1:

The test basis is:

- For PLS 101-312: Type 3 to IEC/EN 61496-1
- For PLS 101-112 and PLS 101-212: Type 3 to EN 50100-1

You can define the **warning field** such that the sensor detects an object before it enters the actual hazardous area, and triggers an alarm signal for example.

Independent of its evaluation of the protective and warning fields, the sensor continuously scans its surroundings within its **measuring range**. You can evaluate this data for additional measuring tasks, such as to navigate a DTS or measure contours.

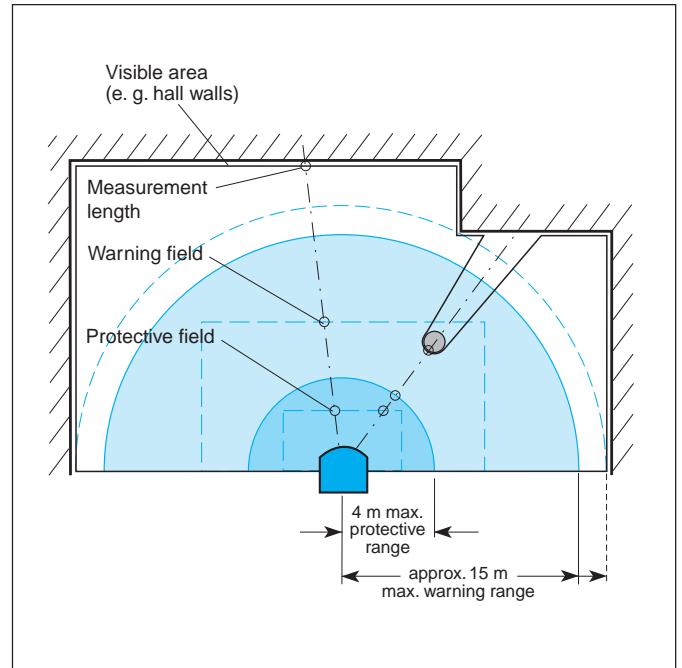

4 Fields of Application – What the PLS Can Do

These pages provide an overview of the key fields of application of the PLS.

Area protection

On hazardous stationary machinery the PLS ensures that the machine (or only its hazardous movement) is shut down as soon as someone enters the hazardous area. This is done by means of a protective field ❶ which you can define according to your needs and store in the PLS.

You can also define a warning field ❷ in front of the actual hazardous area which triggers an alarm signal as soon as someone approaches the hazardous area. The person can then move out of the warning area without the machine or its hazardous movement having to be stopped. This helps you to safeguard continuous production.

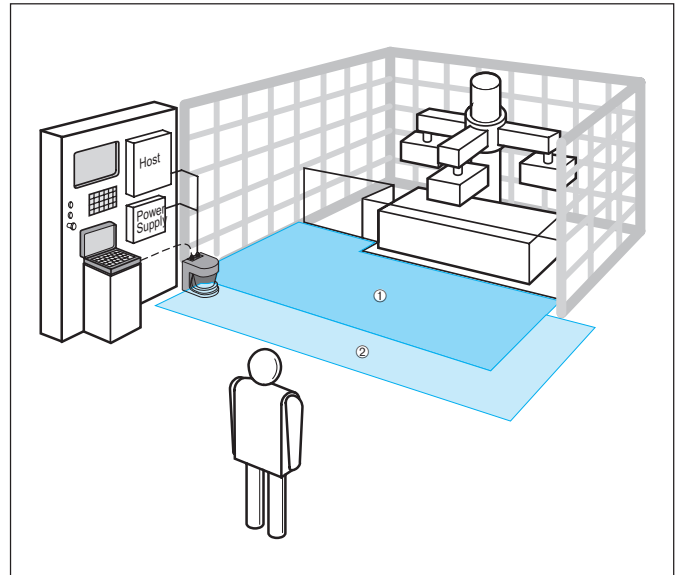

Internal space protection

Where internal spaces exist in large machines, the PLS ensures the machine can only start up when the internal space is clear. This is important especially with regard to internal spaces which are not clearly visible, or not visible at all, from the outside.

In this application the PLS performs only a secondary protective function. The actual personal protection is provided by a light grid, whilst the PLS monitors restarting of the machine.

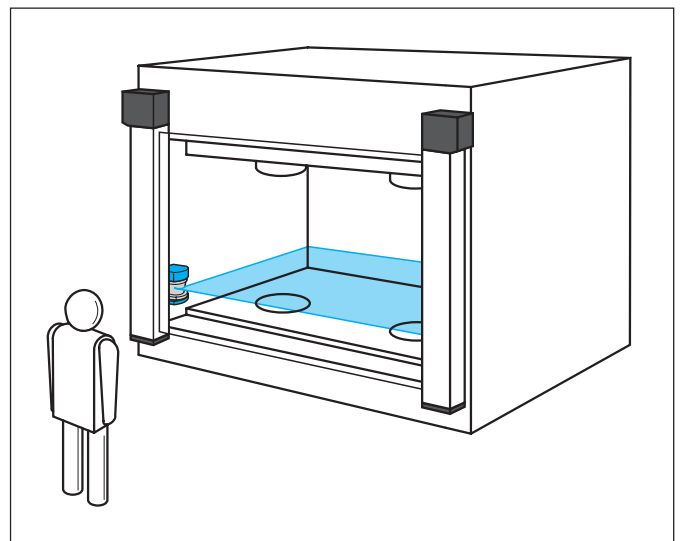

Vehicle protection and navigation

You can employ the PLS on vehicles, such as driverless transport systems (DTS), forklifts and shunting cars, to safeguard a vehicle's path – on its way through a factory hall for example. The protective field ❶ of the PLS then ensures that the vehicle stops if a person or obstacle is standing in the way. You can also define a warning field ❷ which, for example, triggers an alarm signal some distance before the person or obstacle is reached and cuts the speed of the vehicle. You can protect both manually controlled vehicles and driverless transport systems (DTS).

Independent of the protective and warning field settings, the PLS continuously monitors the positions of objects in its surroundings ❸. Vehicles with an internal navigation system can use this ambient data to update their system (PLS 101-31x only). For this, the PLS is permanently linked to the on-board computer of the DTS. The data transmitted by the PLS is encoded in telegrams. The telegram descriptions can be ordered from SICK.

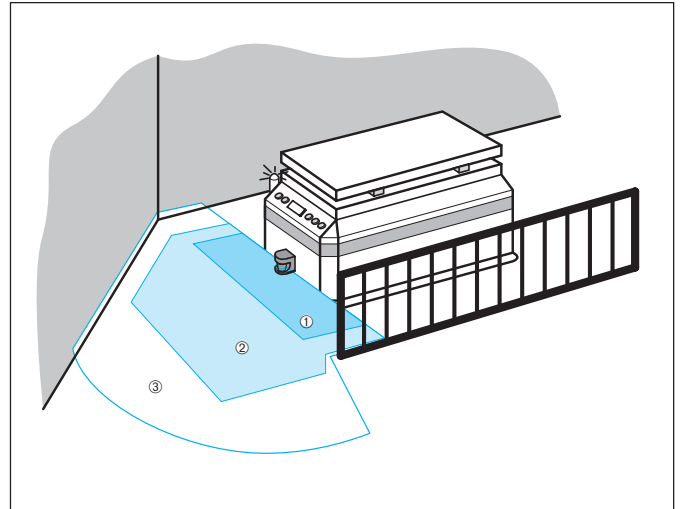

Measurement of contours

You can use the measurement principle of the PLS for a wide variety of measuring tasks, such as:

- Size measurement of goods
- Position detection of goods (e.g. pallets)
- Cross-section measurement in aisles and tunnels
- Profile measurement of goods or vehicles
- Protrusion monitoring of goods in shelves
- Filling level measurement
- Length measurement

If you want solutions for measurement problems of this kind, please order documentation on our series LMS laser scanner, which is suitable for such tasks.

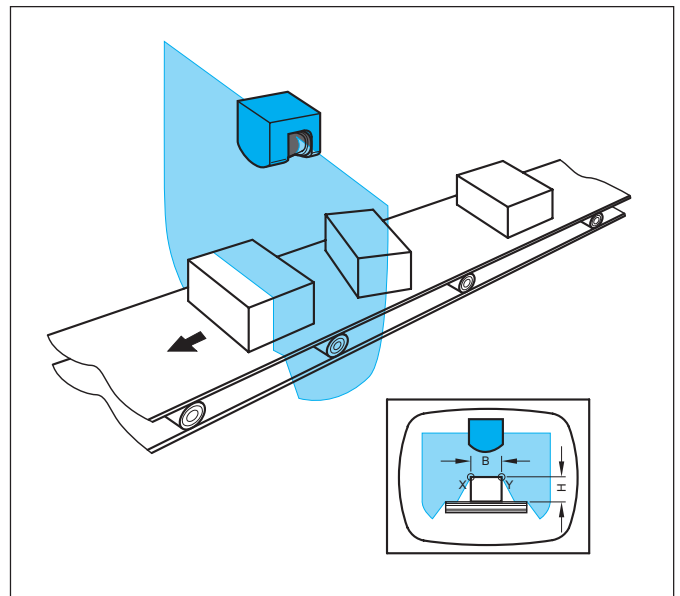

5 Location Planning

The PLS monitors hazardous areas and protects operating personnel and plant. To enable it to fulfill those tasks, you need to observe a number of rules and safety criteria when choosing its location. The key information with regard to this is presented on the following pages.

Note:

It may be that other standards and regulations not cited here are also of importance to your application.

If you are unsure about your application, please contact your local SICK office.

Always choose a location

- which provides the maximum safety in the hazardous area
- in which no obstacles can obstruct the field of vision of the PLS or cause umbra shadows
- in which the PLS is protected against damp, dirt and damage
- in which the PLS is not influenced by sunlight or artificial light sources
- which is as accessible as possible for electrical installation work.

The PLS can in principle be operated in any mounting orientation, for measuring tasks for example. But you should note: When using the PLS in normal area protection and safety applications, only a horizontal orientation of the protective field, with a slight tilt where necessary, is permitted!

Range of the PLS

The PLS measures its surroundings in a semicircular plane (scanning angle 180°). Employment of an optoelectronic safety device as area protection requires a minimum resolution of 70 mm at a specific mounting height. The PLS guarantees this resolution to a distance of 4 metres. Therefore the system software of types PLS 101-312, PLS 101-112 and PLS 101-212 limits the maximum radius of the protective field automatically to 4 metres.

The other PLS types do not have this limitation, and so are not certified for personnel protection.

The **protective field** protecting the hazardous area of a machine or vehicle may have a maximum radius of 4 metres. The PLS shuts the machine down or stops the vehicle in the event of an intrusion into the protective field.

The **warning field** may have any radius up to 50 metres. You should note, however, that the sensor is able to detect objects with a reflectance of approx. 20 - 30 % only to a distance of 15 metres.

The **measuring range** of the PLS extends to a radius of 50 metres. Up to that distance the PLS is able to detect the contour data of its surroundings (e.g. the space contour). It can then additionally evaluate this data for the protective field and the warning field, provided the reflectance of the object is sufficient to be detected.

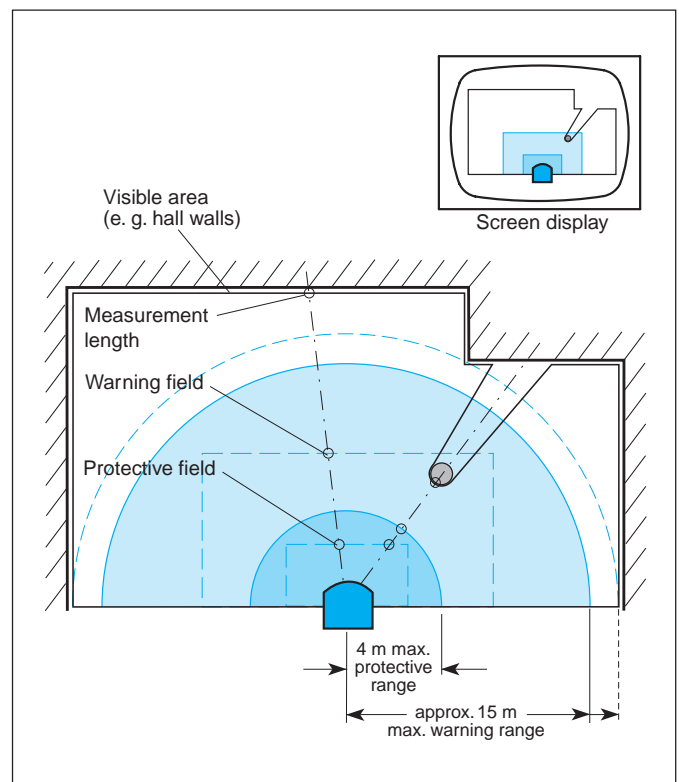

5.1 Stationary protection with PLS

Important notes on configuration

The sensor should preferably be operated in “with restart inhibit” mode for area protection. The regulations applicable to the machine must be observed.

In “with restart inhibit” mode the actuating element for the restart inhibit must be positioned such that there is full visibility of the hazardous area. The actuating element for the restart inhibit must not be accessible from the point directly in front of the sensor.

In “without restart inhibit” mode the close-up zone¹⁾ of the sensor (4 cm wide area measured from the front screen outer contour) is either to be rendered inaccessible (e.g. by a bar or undercut) or a proximity scanner with a 4 cm detection range is to be mounted over the sensor.

For area protection, side access to the machine base is also to be taken into account when configuring the protective field. This assumes that a person approaches the machine base from the side. If side access is possible (no solid restrictions such as a wall), the protective field should be configured wider than the machine base.

In area protection applications it must be ensured that, with protective field widths over 2 metres, there are no retroreflectors in the immediate proximity of the protective field limits on the scanning plane. Otherwise corruption of the measured values is to be expected under extreme conditions. If it is impossible to avoid having retroreflectors in the scanning plane, an extra 20 cm should be added to the maximum measuring error²⁾.

The maximum measuring error is

- 94 mm for protective fields < 2 m
- 131 mm for protective fields > 2 m

Where there are fixed restrictions (walls) there must be no retroreflectors in the scanning plane, as otherwise someone could move along the wall to bypass the protective field.

For both graphic and numeric programming, it must be ensured for reasons of functionality (solid barriers should not lead to unintentional shutdown) that where fixed contours exist a distance of 94 mm for protective fields below 2 metres and 131 mm for protective fields over 2 metres is observed.

Where the teach-in function is used, a 45 mm supplement on top of the maximum measuring error is required for the accuracy of the learned contour.

- ¹⁾ An optical radar cannot distinguish between a dirty front screen and an obstacle directly in front of the sensor. For the sake of functionality, the PLS was designed to reliably detect solid black bodies such as black cord or shoe leather only at a distance of 4 cm measured from the outer contour of the front screen.
- ²⁾ Accuracy of the sensor in safety applications: The sensor determines the distance of an obstacle from the flight time of a very short light pulse. To attain optimum accuracy against obstacles of solid black material (1.8 % reflectance) up to precision triple reflectors (10,000 % reflectance), the PLS compensates the received signal. If there is a dark object in front of a retroreflector, under certain circumstances (see above) the error distance of 20 cm may be too large. This would mean a person could intrude 20 cm into the monitored area without being detected by the PLS. This measuring error occurs only when the following conditions simultaneously apply:
 - The distance to the target is greater than 2 metres.
 - The target is smaller than 140 mm.
 - The retroreflector is on the scanning plane.
 - The reflector is aligned perpendicular to the sensor within an angle of $\pm 30^\circ$.
 - The target reflectance is in the area of 1.8 %.
 - The retroreflector is not more than 2 metres behind the target.
 - The reflector is clean and high-quality.

Location planning

There are two basic alternative procedures for defining mounting locations:

First option: Using the so-called teach-in mode. In this mode the PLS measures the ambient contour and stores it (after automatic correction) as the outer protective field limit. The following formulae must be applied to check compliance with the relevant specifications, such as the safety distance and mounting height, retrospectively.

Second option: Using graphical or numerical protective field input. In this the specifications to be complied with are ascertained at the outset and are then set in programming of the scanner.

The basis for planning the mounting location of the PLS is pr EN 999. It describes the necessary minimum safety distance from the hazardous area by:

$$S = (K \times T) + C$$

Where:

- S is the minimum distance in millimetres, measured from the hazardous area to the detection point, detection line, detection plane or protective field;
- K is a parameter in millimeters per second, derived from data relating to approach speeds of the body or body parts;
- T is the stopping time of the overall system in seconds;
- C is an additional distance in millimetres which takes account of the possibility of intrusion into the hazardous area before tripping of the safety device.

In access protection applications, an approach speed of 1600 mm/s is applied as K.

T results from addition of the response time of the sensor and the stopping time of the hazardous movement.

C describes the possibility of reaching over the protective field without tripping the sensor, and varies with the height of the protective field limit according to the following correlation:

$$C = 1200 \text{ mm} - 0.4 H_D \text{ (} H_D = \text{height of detection)}$$

where $C > 850 \text{ mm}$

Consequently:

$$\text{Where } H_D = 0 : C_{HD=0} = 1200 \text{ mm}$$

$$\text{Where } H_D = 875 : C_{HD=875} = 850 \text{ mm}$$

This correlation is shown graphically in the adjacent diagrams (cases 1 and 2).

Note:

The protective field supplement C is to be chosen dependent on the height of detection H_D .

In case 2b, protection of marginal areas, note that the scanning plane is not raised.

Also note that if the sensor is not mounted parallel to the floor the effective protective field length is reduced.

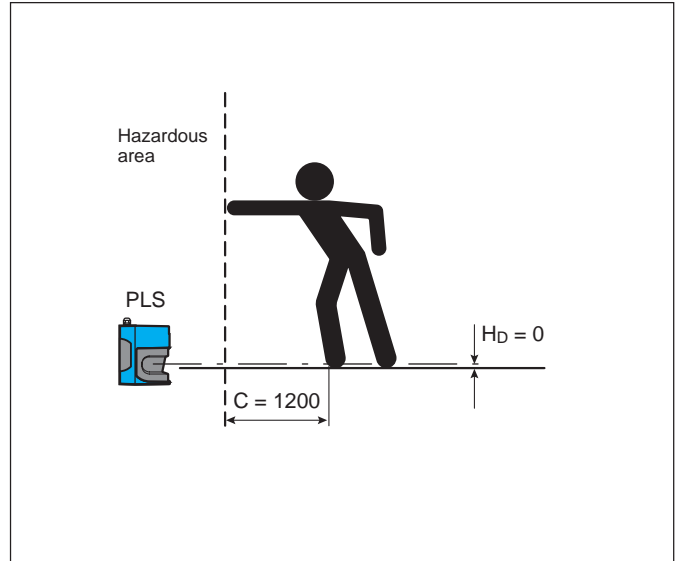

Case 1: Scanning plane parallel to ground ($H_D = 0$)

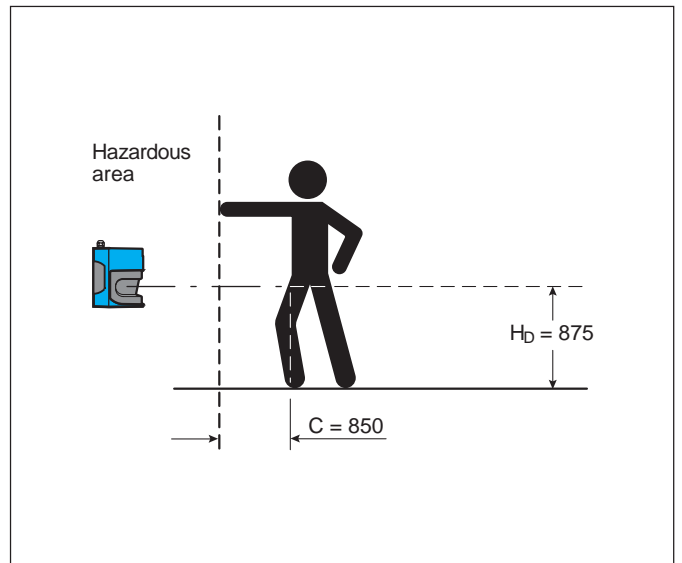

Case 2a: Scanning plane at maximum height and parallel to ground. ($H_D = 875$)

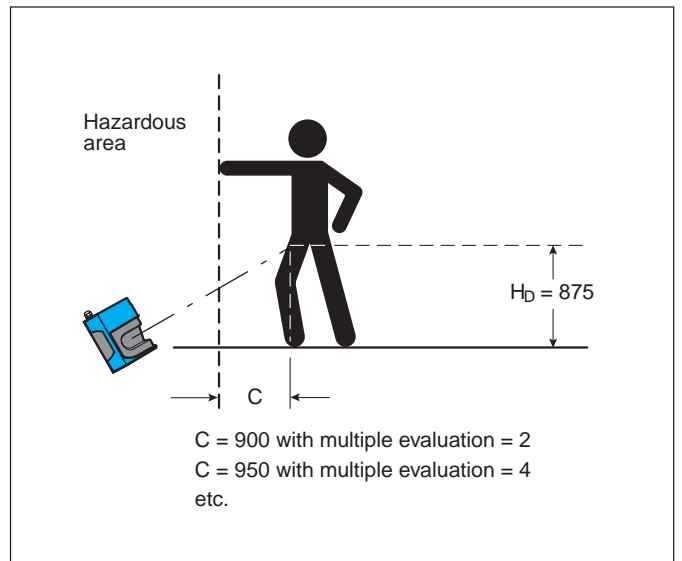

Case 2b: Scanning plane at maximum height, not parallel to ground ($H_D = 875$)

As a secondary condition pr EN 999 stipulates the following minimum height:

$$H_D = 15 \times (d - 50) \text{ mm}$$

Application of this formula is necessary as the leg diameter changes with the distance from the floor. In this, d is the resolution of the PLS (d is dependent on the distance from the scanner).

The resolution of the scanner must always be determined at the point of greatest measuring distance, i.e. at the greatest occurring protective field length SL_{max} .

Based on the working principle of the PLS by means of radial scanning of the surroundings, a resolution is produced which decreases as the distance from the sensor increases.

Thus a protective field length SL greater than 2.70 meters (only up to this distance is a scanner resolution of 50 mm guaranteed) makes a certain detection height necessary. In this way it is possible to compensate for the lower resolution with greater leg diameter.

These correlations between SL , H_D , H_S and C are shown graphically in the adjacent diagrams. In this, H_S is the height of the scanner plane, measured directly on the sensor.

With horizontal mounting there is no risk of unwanted accessing at mounting heights below 100 mm (for example crawling under the scanning plane). To prevent children from crawling underneath, the maximum mounting height is 200 mm max. Mounting heights of less than 100 mm are generally not to be recommended, as in such cases it is possible that the scanner may accidentally shut down as a result of the increased dust concentration directly on the floor. For these reasons this mounting range is often preferred, and consequently is identified as such in the diagram.

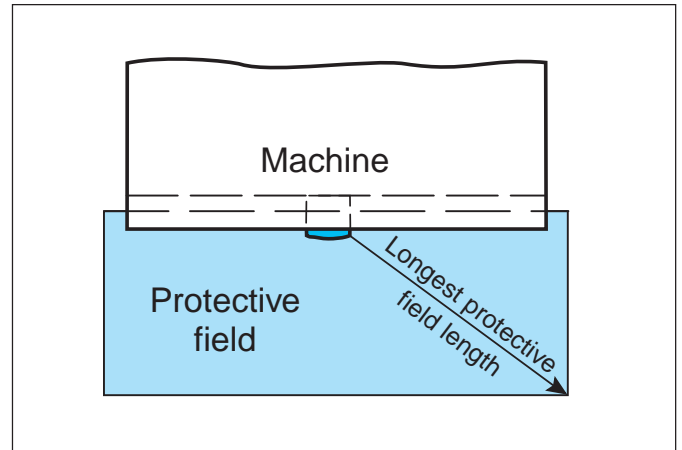

Resolution of the scanner at the point of longest protective field length SL

Using the diagram:

Define the maximum protective field length SL_{max} in your layout. Shift the right Y-axis (H_D) in parallel onto the located value SL_{max} . Then place the desired scanning plane in the remaining area shaded light gray. The plotted scanning line must not leave the gray area at any point.

Within the area shaded gray in the diagram any mounting orientation is possible, provided it does not impair the safety distance.

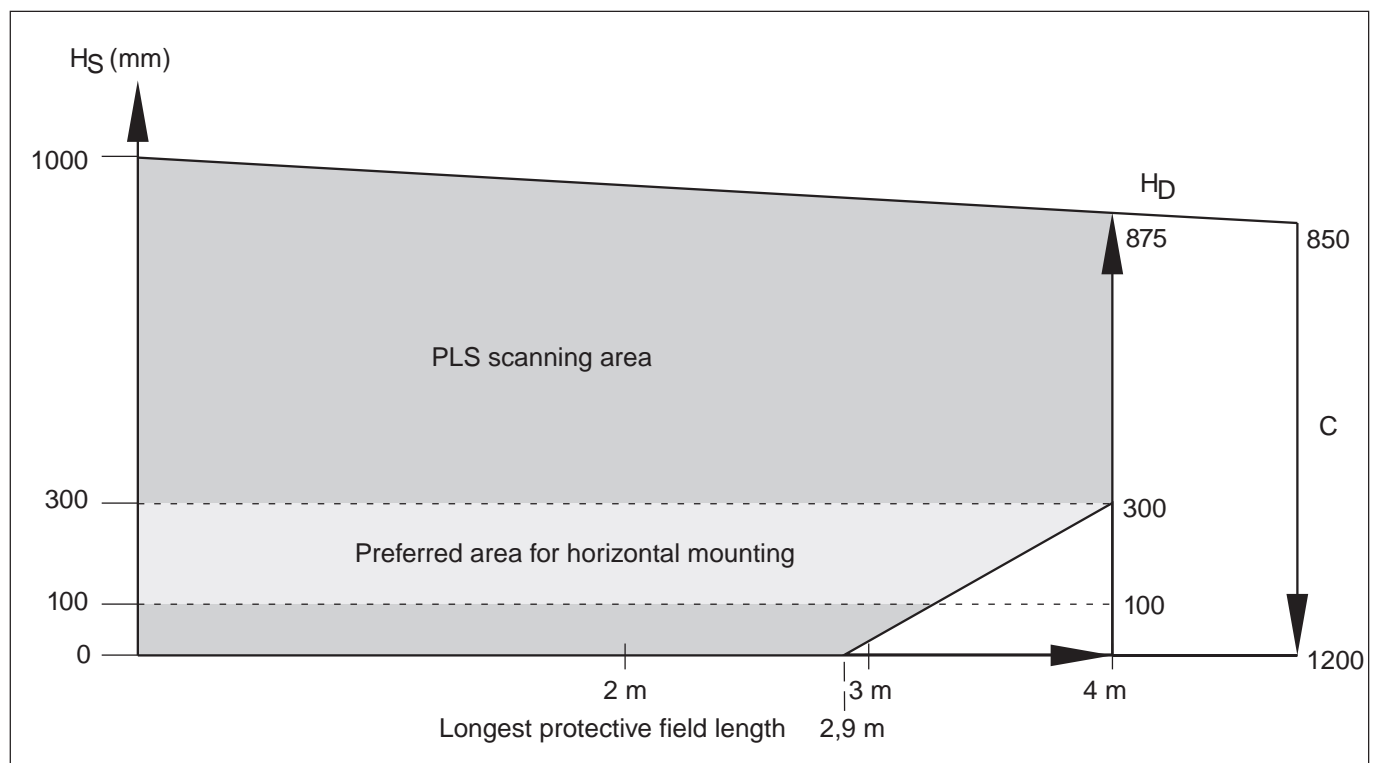

Correlation between protective field length, resolution of sensor and height of scanning plane

Read-off example:

You determine a maximum protective field length of 3.50 metres. To determine the minimum field length at the edge of the protective field, shift the right Y-axis in parallel onto the value 3.50 metres. You will then see that the detection height must not be lower than 150 mm. The mounting height of the sensor is freely selectable up to a height of 1000 mm. Thus the scanning plane does not go beyond the gray area.

Note:

Please note that the height of the beam H_S is 63 mm above the bottom edge of the housing.

There are three common mounting orientations for the PLS. The optimum mounting orientation depends on the situation. The table provides some assistance in making the right choice.

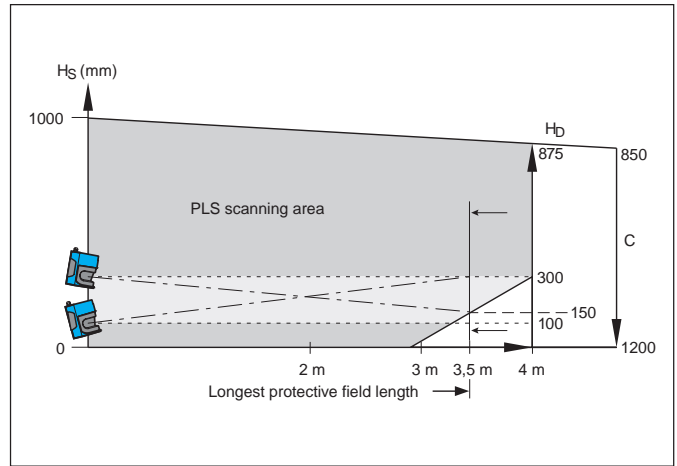

Scanner setting	Advantages	Disadvantages
Case 1: Scanner low ($H_S < 300$ mm) Scanning plane inclination low (H_D approximately H_S)	No external influence due to glare, no possibility of crawling underneath	Large protective field supplement C
Case 2: Scanner high ($H_S > 300$ mm) Scanning plane inclination low (H_D approximately H_S)	Small protective field supplement C	Danger of crawling underneath (at front and side)
Case 3: Scanner low ($H_S < 300$ mm) Scanning plane inclination high ($H_D < H_S$)	Small protective field supplement C	Danger of crawling underneath (at front), poss. external influence due to glare

Any other mounting orientation and intermediate height which prevents a hazardous situation being reached is possible, provided the safety distance is observed. Always take account of the marginal area protection.

The protective field supplement C is determined on the basis of the choice of mounting orientation. We recommend for a first calculation:

- In case 1: $C = 1200$ mm
- In case 2: $C = 1000$ mm
- In case 3: $C = 1000$ mm

The formula to be applied is:

$$S = (1600 \text{ mm/s} \times T) + C + Z_M + Z_R + Z_E$$

Where: Z_M is a supplement for the general measuring error of the PLS
 Z_R is a supplement for any reflection-related measuring error of the PLS
 Z_E is a supplement for the measuring error of the PLS resulting from teach-in (see Important notes on configuration for stationary protection).

Note:

Every time the parameters are changed, check that the protective field is still adequately dimensioned and that no unwanted access (from the side or by crawling underneath the scanning plane) is possible!
Make sure that all necessary supplements are taken into account in the calculation.

Restart definition

The machine should preferably be operated with restart inhibit. If the machine control has no restart inhibit, the internal restart inhibit of the PLS can be used.

A restart inhibit is always essential when the protective field can be exited toward the hazardous area. Where necessary, check whether this can be prevented by plant design (see following subsection: Mounting recommendations for PLS).

If a machine can only be operated without restart inhibit, it is essential that the following points should be observed:

- A person must be reliably detected at every point in the hazardous area.
- A person must not be allowed to exit the protective field in the direction of the hazardous area (such as by crawling underneath it, stepping behind it or climbing over it).

Make sure this is prevented by plant design (see following subsection: Mounting recommendations for PLS)!

Mounting recommendations for PLS

The following observations are to be applied in designing the plant:

The mirror pivot point of the PLS determines the position of the front edge of the protective field. Since the mounting area and the mirror pivot point are at a set distance from one another, a zone is produced in front of the mounting area which is not detected by the scanner.

This zone becomes larger if the PLS is mounted on the mounting bracket, for example. The size of this dead zone – measured from the back edge of the PLS or the mounting kit – is:

PLS direct-mounted:	109 mm
PLS with mounting kit 1:	112 mm
PLS with mounting kit 1 and 2:	127 mm
PLS with mounting kit 1, 2 and 3:	142 mm

There are cases in which design measures must be applied to prevent persons from being in the hazardous area but outside the protective field (such as by crawling underneath it, stepping behind it or climbing over it).

To exclude this possibility where a laser scanner is mounted on the machine, one of the following measures (or a combination of them) is essential:

- Undercutting
- Retraction of the laser scanner
- Mounting of the laser scanner opposite or to the side of the machine base

Undercutting:

The undercut must always be at least as low as the dead zone. With regard to the mounting height the observations presented under “Location planning” apply.

To prevent entry into the undercut, it is necessary to limit its height.

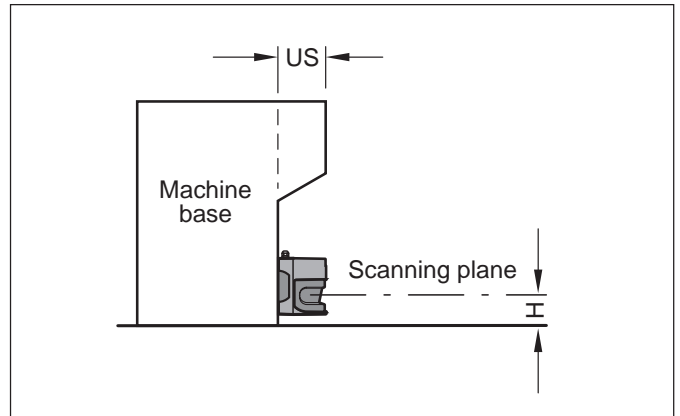

Undercutting

Retraction of the laser scanner:

Retraction of the laser scanner into the machine contour presents an alternative to the undercut.

However, retracting the PLS too far will mean that the scanner is unable to monitor the full 180°. In such cases you need to design the shadow sides to be inaccessible (point-of-operation guard).

If you need to monitor the full 180°, for geometric reasons the retraction depth of the scanner must be limited to a maximum of 69.5 mm (corresponding to a protrusion of the PLS beyond the front of the machine of at least 86.5 mm).

The observations regarding the detection reliability of the PLS and the stipulations of pr EN 999 result in the following correlation between the minimum height of the scanning plane on the scanner H_{Smin} and the protrusion Z from the front of the machine:

$$H_{Smin} = 15 \times (Z - 90)$$

where: $H_s \leq 1000\text{mm}$, $86.5 \text{ mm} \leq Z \leq 156 \text{ mm}$

Note:

Before the scanner is mounted it is essential that the height of the scanning plane H_s should be translated into the attachment height H_A !

The necessary dimensions of the scanning plane in relation to the fixing holes for the scanner are shown in the dimensional drawings in the section headed “Mounting the PLS”.

The minimum mounting height is based on the retraction depth. The deeper you can retract the PLS, the lower you can mount it. Take into consideration the possible shadowing of the marginal areas when retracting the scanner. With regard to the resolution of the PLS and the danger of crawling underneath the scanning plane, the points made under “Location planning” apply.

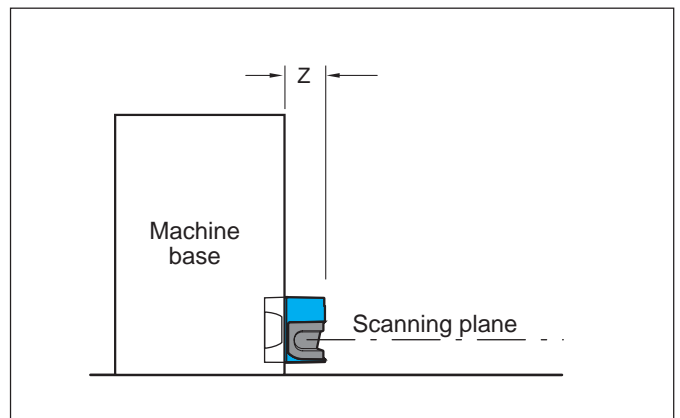

Scanner retraction

Mounting of the laser scanner opposite or to the side of the machine base:

If the PLS is in the way when installed on the machine base, it can alternatively be mounted opposite. For this, because of the measuring tolerance of the PLS, it is essential that an undercut be made in the machine base.

The necessary minimum undercut US_{min} on the machine is calculated on the basis of:

$$US_{min} = (2 \times SF_{distance}) - d = (2 \times \text{max. measuring error}) - d$$

The maximum measuring error is dependent on the size of the maximum protective field length, and at up to 2 metres maximum measuring distance is 94 mm; at over 2 metres maximum measuring distance 131 mm. The resolution at this measuring distance is given in the diagram. For application of this formula the distance between the protective field limit and the machine base must not be greater than the maximum measuring error. If the protective field limit is further away from the machine, US_{min} is increased accordingly.

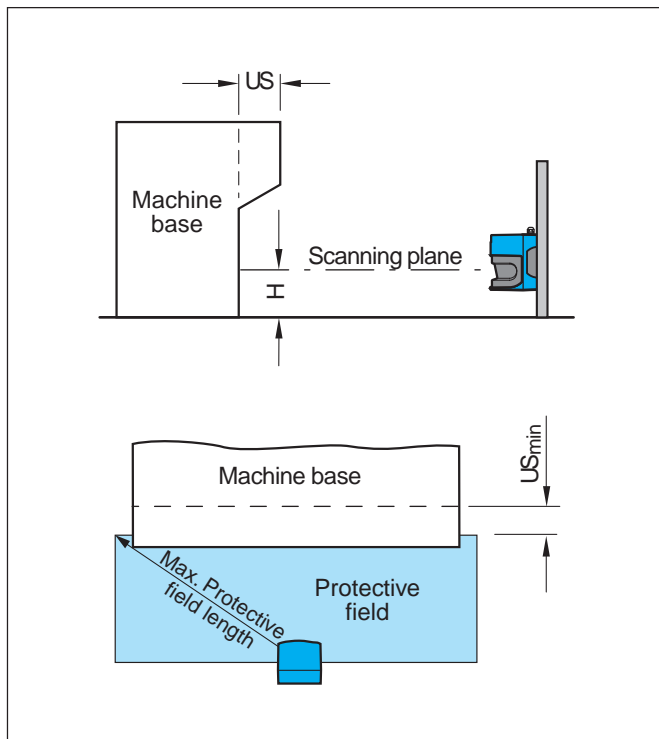

Mounting of a PLS opposite or to the side of the machine base

Read-off example:

In your protective field you determine the maximum protective field length as 3500 mm. From the diagram you read off a resolution d_{max} of 60 mm.

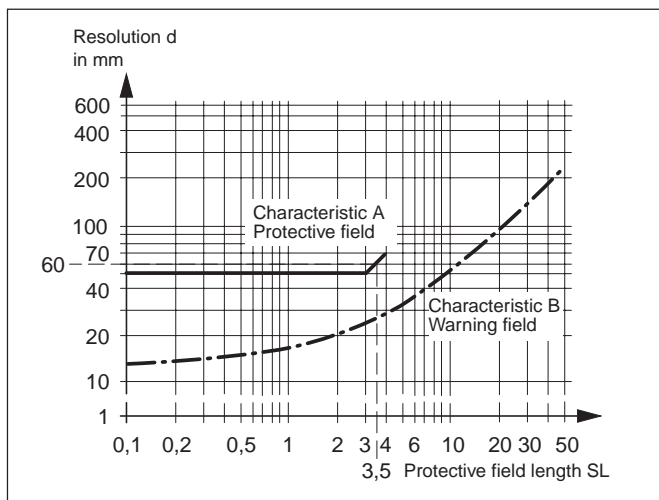

Diagram: Protective field length and resolution

5.2 Mobile protection with PLS

In mobile protection the sensor can be operated both with and without restart inhibit, depending on application. The regulations applicable to the vehicle must be observed.

In “with restart inhibit” mode the actuating element for the restart inhibit must be positioned such that there is full visibility into the hazardous area. The actuating element for the restart inhibit must not be accessible from the point directly in front of the sensor.

In “without restart inhibit” mode the close-up zone¹⁾ of the sensor (4 cm wide area measured from the front screen outer contour) is either to be rendered inaccessible (e.g. by a bar or undercut) or a proximity scanner with a 4 cm detection range is to be mounted over the sensor.

For mobile protection, side access to the vehicle is also to be taken into account when configuring the protective field. This assumes that a person approaches the vehicle from the side, for example in concealed areas (crossways). If side access is possible (no solid restrictions such as a wall), the protective field should be configured wider than the vehicle.

In mobile protection applications it must be ensured that, with protective field widths over 2 metres, there are no retroreflectors in the immediate proximity of the protective field limits on the scanning plane. Otherwise corruption of the measured values is to be expected under extreme conditions. If it is impossible to avoid having retroreflectors in the scanning plane, an extra 10 cm should be added to the maximum measuring error²⁾. The halving of the supplement in relation to stationary applications is due to the dynamics.

The maximum measuring error is

- 94 mm for protective fields < 2 m
- 131 mm for protective fields > 2 m

Where there are solid restrictions (walls) there must be no retroreflectors in the scanning plane, as otherwise someone could move along the wall to bypass the protective field.

For both graphic and numeric programming, it must be ensured for reasons of functionality (solid barriers should not lead to unintentional shutdown) that where fixed contours exist a distance of 94 mm for protective fields below 2 metres and 131 mm for protective fields over 2 metres is observed.

Where the teach-in function is used, an additional 45 mm on top of the maximum measuring error is required for the accuracy of the learned contour.

- ¹⁾ An optical radar cannot distinguish between a dirty front screen and an obstacle directly in front of the sensor. For the sake of functionality, the PLS was designed to reliably detect solid black bodies such as black cord or shoe leather only at a distance of 4 cm measured from the outer contour of the front screen.
- ²⁾ Accuracy of the sensor in safety applications: The sensor determines the distance of an obstacle from the flight time of a very short light pulse. To attain optimum accuracy against obstacles of solid black material (1.8 % reflectance) up to precision triple reflectors (10,000 % reflectance), the PLS compensates the received signal. If there is a dark object in front of a retroreflector, under certain circumstances (see above) the error distance of 10 cm may be too large. This would mean a person could intrude 10 cm into the monitored area without being detected by the PLS. This measuring error occurs only when the following conditions simultaneously apply:
 - The distance to the target is greater than 2 metres.
 - The target is smaller than 140 mm.
 - The retroreflector is on the scanning plane.
 - The reflector is aligned perpendicular to the sensor within an angle of $\pm 30^\circ$.
 - The target reflectance is in the area of 1.8 %.
 - The retroreflector is not more than 2 metres behind the target.
 - The reflector is clean and high-quality.

Location planning

The following observations take into account only the vehicle speed, not the speed of a moving person. The reason is that it is assumed that a person approaching the vehicle recognizes the danger and at least stands still.

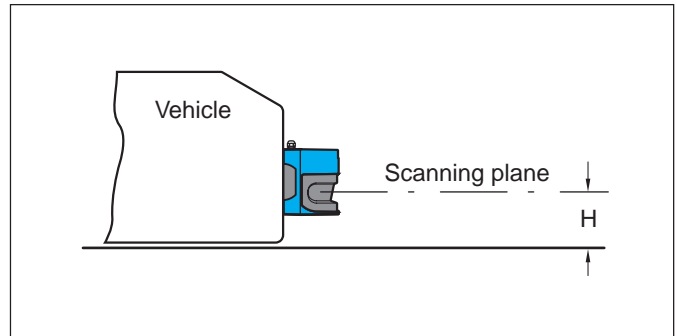

Mounting of a PLS on a vehicle

Attachment height:

Due to the intrinsic movement of the scanner in the mobile application, a resolution of 70 mm is adequate for detection of persons in mobile applications (stationary application: 50 mm). For this reason, the mobile application requires no higher-level mounting for protective field widths over 2.90 meters.

The sensor is to be calibrated in accordance with EN 1525 such that a body of maximum 200 mm height under all circumstances is detected in the protective field range necessary to bring the vehicle to a safe stop. (Recommendation: setting to 150 mm height).

The scanning plane should not be below 100 mm, as the increased dust concentration on the floor could cause the scanner to shut off unintentionally.

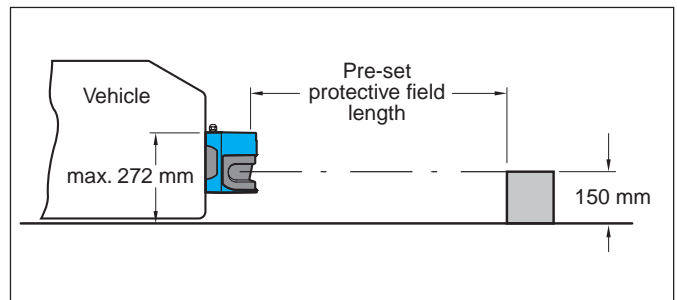

Mounting height

Attachment mode:

A basic distinction is made between two modes of attachment:

Protruding front mounting:

The dead zones created at the sides of the sensor in protruding front mounting must be eliminated by mechanical trim covers or switch strips, or the vehicle must not be accelerated to speeds above 0.3 m/s in less than three seconds.

Integral in vehicle trim panel:

The sensor is installed such that no dead zones, or no dead zones < 70 mm, are created to the side of it. The vehicle may then be accelerated to a speed of 0.3 m/s within one second. In order to meet this condition, the PLS must not protrude more than 109 mm over the front edge of the vehicle.

If the close-up zone of the sensor (4 cm wide area measured from the front screen outer contour) is either rendered inaccessible (e.g. by a bar or undercut) or is monitored by a proximity scanner or a switch strip with a 4 cm detection range, the vehicle may be accelerated at will.

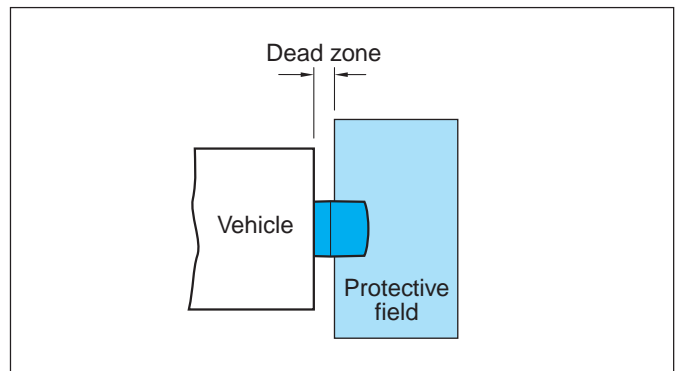

Mounting mode: Protruding front mounting

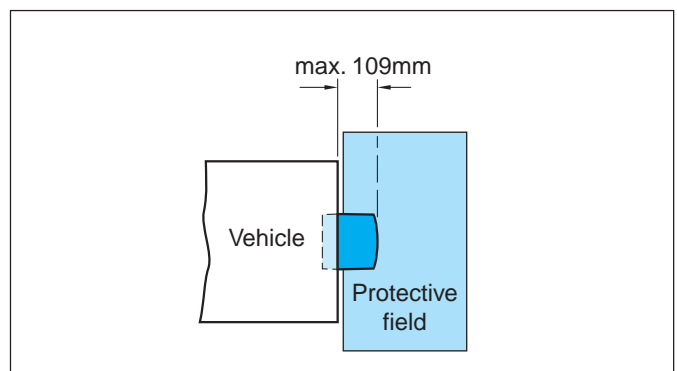

Mounting mode: Integral in vehicle trim panel

Calculation of the necessary protective field

When configuring the protective field for vehicle applications, in addition to the actual stopping distance of the vehicle the following supplements must also be taken into account:

For the protective field length SL:

$$SL = S_A + Z_M + Z_R + Z_E + Z_F + Z_B$$

where: S_A is the stopping distance of the vehicle

Z_M is the supplement for the general measuring error of the vehicle;

Z_R is the supplement for any reflection-related measuring error of the PLS;

Z_E is the supplement for the measuring error of the PLS resulting from teach-in (see Important notes on configuration for mobile protection);

Z_F is the supplement for a lack of ground clearance of the vehicle;

Z_B is the supplement for the decreasing braking force of the vehicle.

The stopping distance S_A is composed of the actual braking distance of the vehicle from maximum speed and the maximum load S_{Br} , as well as its distance covered during the response time of the sensor S_{Ans} .

$$S_A = S_{Br} + S_{Ans}$$

where: S_{Br} is given in the specification of the vehicle manufacturer;

$$S_{Ans} = T_{Ans} \times V_{max} \text{ ist.}$$

The response time of the sensor T_{Ans} set when the PLS is shipped is 80 ms.

The supplement Z_M results from the maximum measuring distance of the PLS. For measuring distances up to 2 meters the maximum measuring error is 9.4 cm; for measuring distances above 2 meters the error is 13.1 cm. The maximum protective field length SL_{max} results from the maximum distance of the edge of the protective field from the center of the PLS (see Important notes on configuration for mobile protection).

The supplement Z_R is necessary when there are objects with retroreflective properties on the scanning plane. If the presence of retroreflectors cannot be excluded, for protective field lengths above 250 cm a supplement of 10 cm is required (see Important notes on configuration for mobile protection).

The supplement Z_E is necessary when you define the protective field by the teach-in method. This supplement takes account of the accuracy in registering the ambient contour. This supplement is independent of background conditions, and needs to be set at a constant 45 mm.

The supplement Z_F is necessary because people are generally detected above foot level, and so the braking action is unable to take account of the length of the foot in front of the point of detection. A person could therefore suffer injuries to the foot as a result of a lack of ground clearance.

The adjacent diagram shows the necessary extension of the protective field based on the supplement necessary for the lack of ground clearance of a vehicle.

The supplement for the declining braking force of the vehicle Z_B must be set at 10% of the stopping distance, unless already taken into account in the stopping distance.

The protective field width S_B also requires a supplement. Here the supplement Z_M for the general measuring error of the PLS is applied (as necessary Z_R and Z_E).

As Z_M for the protective field width – like Z_M for the protective field length - results from the maximum protective field length SL_{max} , those supplements are always identical.

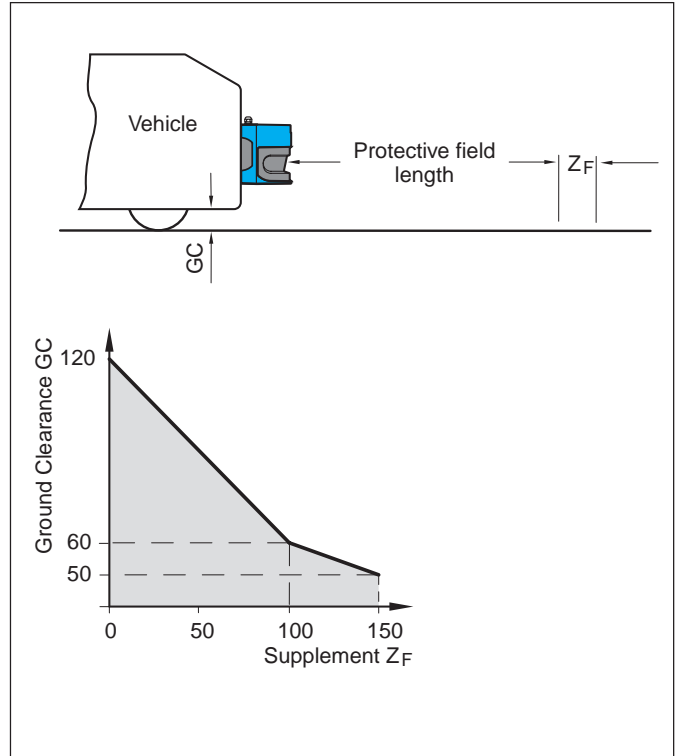

Supplement on protective field resulting from lack of ground clearance

Configuration examples

Notes:

In the user software always enter whole values in centimeters. For this, the results of all calculations must be rounded up to 1 cm.

The stopping distance s is the stopping distance required by the vehicle (including the sensor response time) from maximum speed.

Calculation example 1: (Scan rate set as default)

Stopping distance: 180 cm (taking into account brake wear)
 Vehicle width: 140 cm (PLS arranged in the center)
 Ground clearance: > 12 cm

Max. measuring distance = $\sqrt{180^2 + 70^2} = 193.1$ cm
 $Z_L = 9.4$ cm measuring error PLS (max. measuring distance < 2 m)
 + 0 cm for ground clearance (ground clearance > 12 cm)
 + 0 cm for brake wear (already included in stopping distance)

= 9.4 cm

The protective field length to be configured is 190 cm.

$Z_B = 9.4$ cm measuring error PLS

= 9.4 cm

The protective field width to be configured is 80 cm (on both sides of the PLS).

Calculation example 2: (Scan rate set as default)

Stopping distance: 300 cm (excluding brake wear)
 Vehicle width: 200 cm (PLS arranged in the center)
 Ground clearance: < 5 cm
 Retroreflectors may occur on the scanning plane.

Max. measuring distance = $\sqrt{300^2 + 100^2} = 316.2$ cm
 $Z_L = 13.1$ cm measuring error PLS (max. measuring distance > 2 m)
 + 15.0 cm for ground clearance (ground clearance < 5 cm)
 + 30.0 cm for brake wear
 + 10.0 cm for possible retroreflectors on scanning plane

= 68.1 cm

The protective field length to be configured is 369 cm.

$Z_B = 13.1$ cm measuring error PLS
 + 10.0 cm measuring error reflection Z_R

= 23.1 cm

The protective field width to be configured is 124 cm (on both sides of the PLS).

5.3 If you use several PLS units

The PLS is designed such that mutual interference by sensors where more than one are deployed is highly unlikely.

To be absolutely sure of avoiding error shutdowns, you should mount the sensors offset to one another. The diagrams show various options.

In any event, be sure to observe the stipulations of pr EN 999.

There are three different mounting kits which will allow you to align the sensors at various angles.

You will find diagrams illustrating all mounting kits and more detailed information in the section headed "Mounting the PLS".

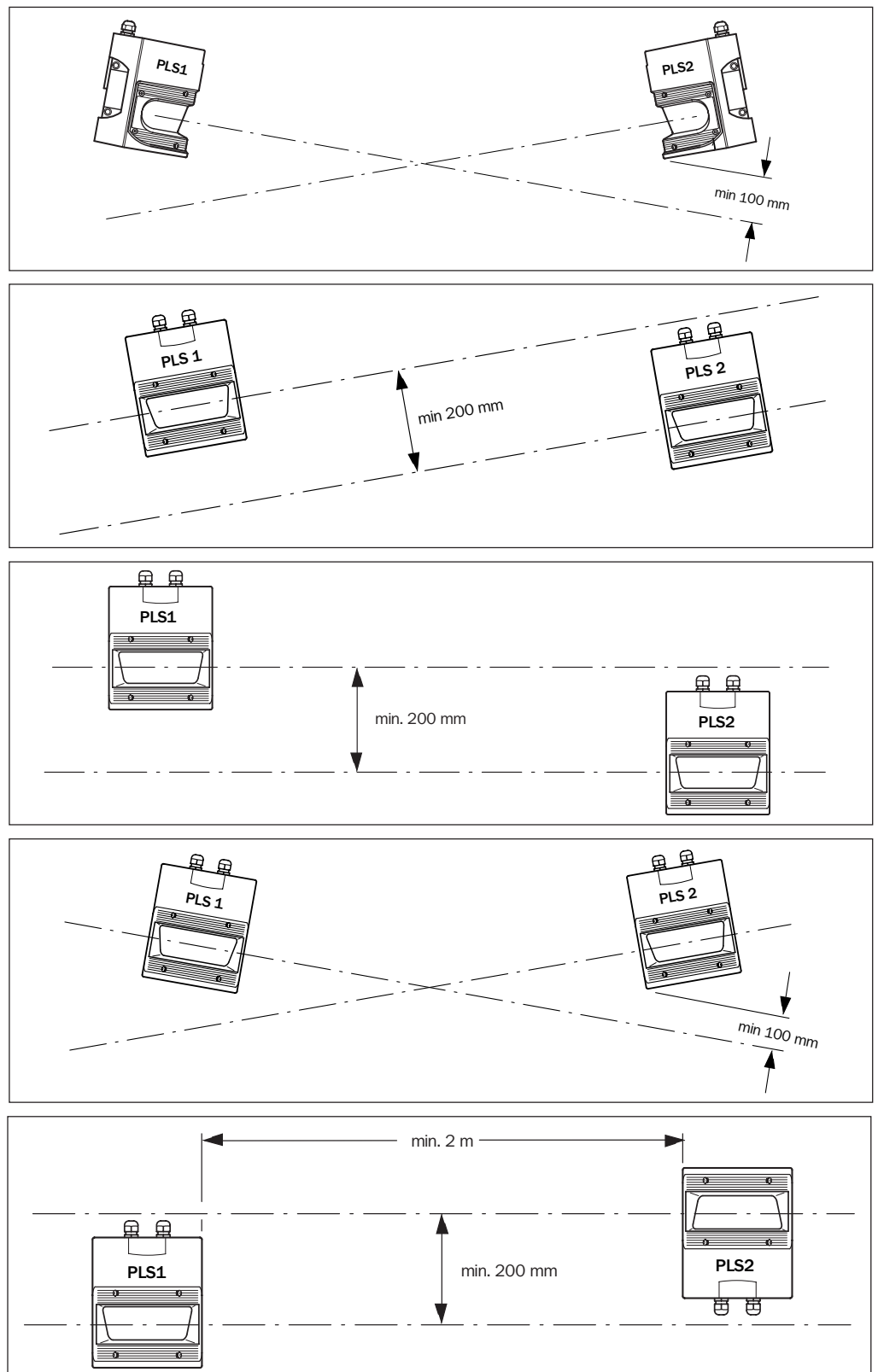

6 Supply Package

You receive:

- a PLS sensor
- a connection set (one connection box each for power supply and interface)
- the PLS user software (on a 3.5" floppy)
- the operating instructions manual
- this technical description manual.

Recommended accessories

At this point we can only give you a few pointers to the major accessories. You will find a complete list in the Appendix.

Connection set

You will normally receive connection set 1. It contains one connection box each for the power supply and the interface, without cables.

If you wish, instead of connection set 1 you can order one of the connection sets 2 to 7, which include a cable fitted to the power connector. The cable is routed upward out of the connection box.

Various cable lengths are available:

	Order no.
Connection set 2, with 3 m cable	2 016 185
Connection set 3, with 5 m cable	2 016 186
Connection set 4, with 10 m cable	2 016 187
Connection set 5, with 15 m cable	2 016 188
Connection set 6, with 20 m cable	2 016 189
Connection set 7, with 30 m cable	2 016 190

Interface cable

To connect the sensor to a PC you can use the interface cable. It is available in three lengths.

For RS 232 (all PLS types) and for RS 422 (PLS type 101-212):

	Order no.
3 m interface cable	2 016 401
5 m interface cable	2 016 402
10 m interface cable	2 016 403

For RS 422 (PLS types 101-312 only):

	Order no.
3 m interface cable	2 019 130
5 m interface cable	2 019 131
10 m interface cable	2 019 132

7 Mounting the PLS

You can mount the PLS without additional fixings directly on a wall or on the floor. Threaded holes are provided for this on the bottom and on the back of the PLS.

Note:

Mount the PLS so it is protected against damp, dirt and damage.

Also avoid excessive shock and vibration impact on the scanner. Please observe the relevant specifications set out in the Appendix under "Technical data".

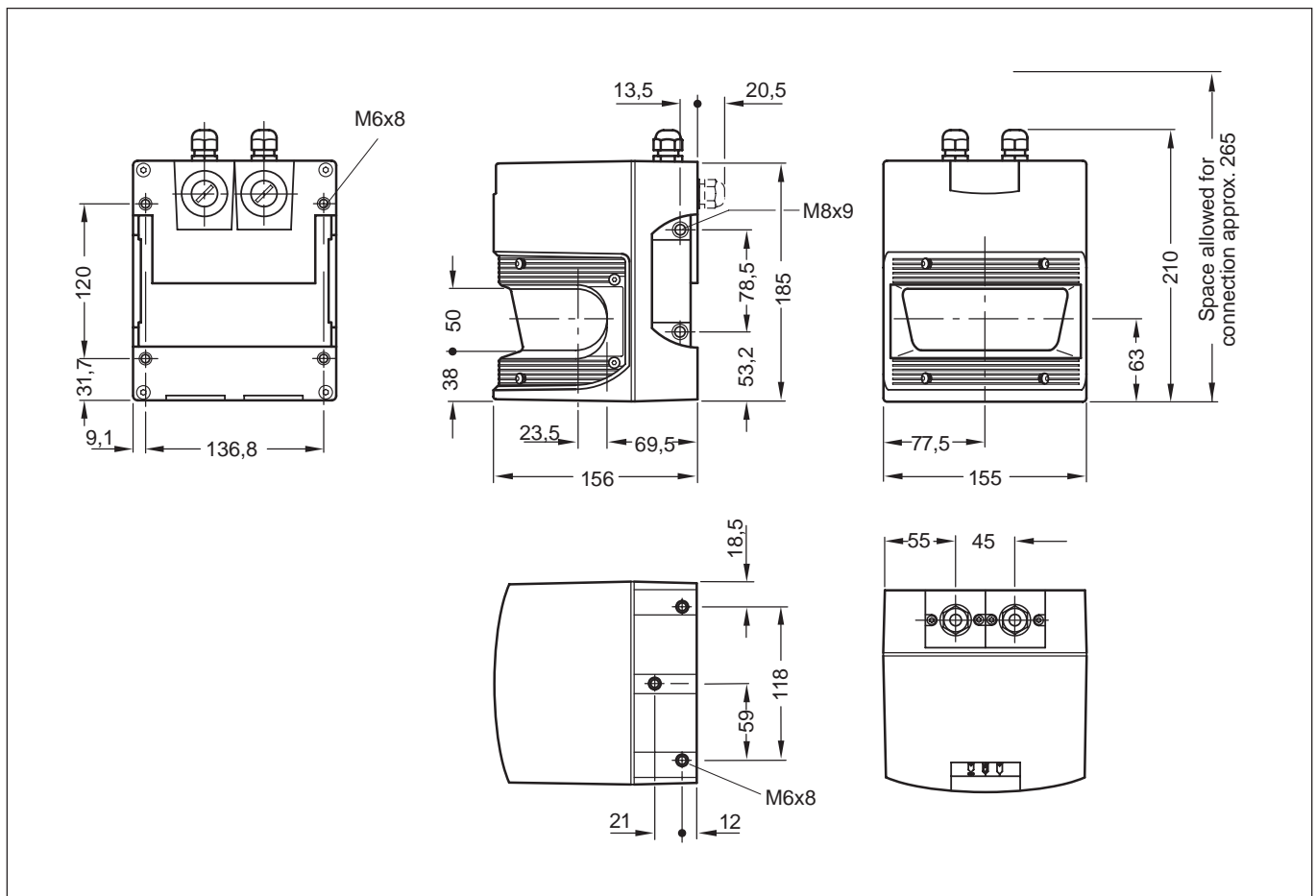

(All dimensions in mm)

There are three mounting kits which allow the PLS to be fine-adjusted and then securely fixed in position.

Mounting kit 1 is attached directly to the back of the PLS, and is for wall mounting. The contact areas on the PLS and on mounting kit 1 are so precise that you can replace the PLS at any time without re-aligning, if this becomes necessary.

Mounting kit 2 is attached as an add-on to mounting kit 1, and permits fine adjustment of the PLS in two planes (see arrows in illustration). The maximum adjustment angle is $\pm 11^\circ$.

Mounting kit 3 (only in conjunction with mounting kits 1 and 2) can be used either for stable floor mounting of the PLS or, on uneven wall surfaces, ensures that the transverse axis on mounting kit 2 remains precisely adjustable. The maximum adjustment angle is $\pm 3.3^\circ$.

Dimensional drawings for all mounting kits are set out on the next page.

Note:

Where systems are subject to heavy vibration, you should prevent the adjusting and fixing screws from working loose by suitable locking mechanisms, and regularly check that the screws are tight.

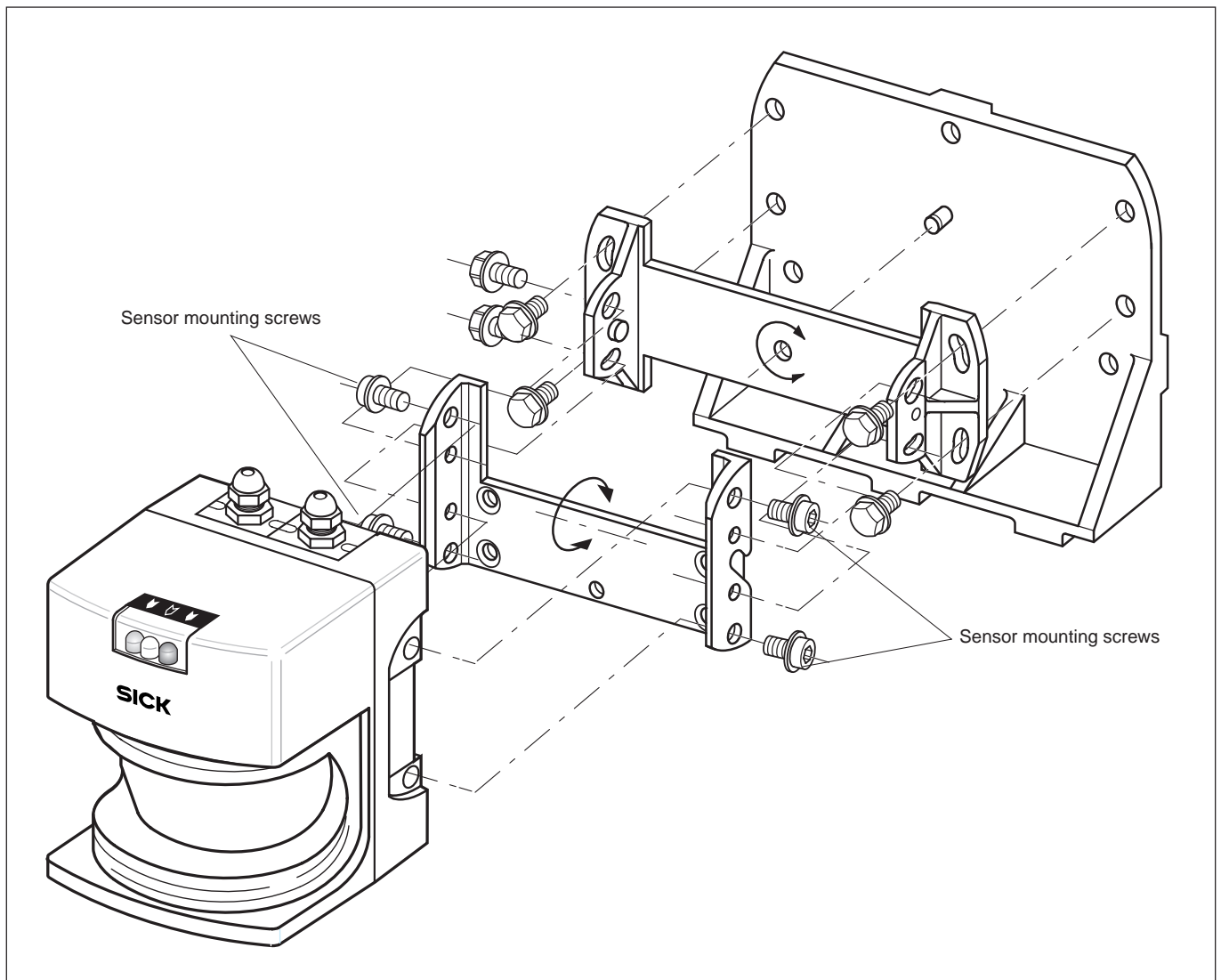

Notes:

The scanning plane is 63 mm above the bottom edge.

When a PLS is mounted using mounting kits 1, 2 and 3, the scanning plane (with horizontal alignment) is 102.5 mm above the bottom edge of mounting kit 3.

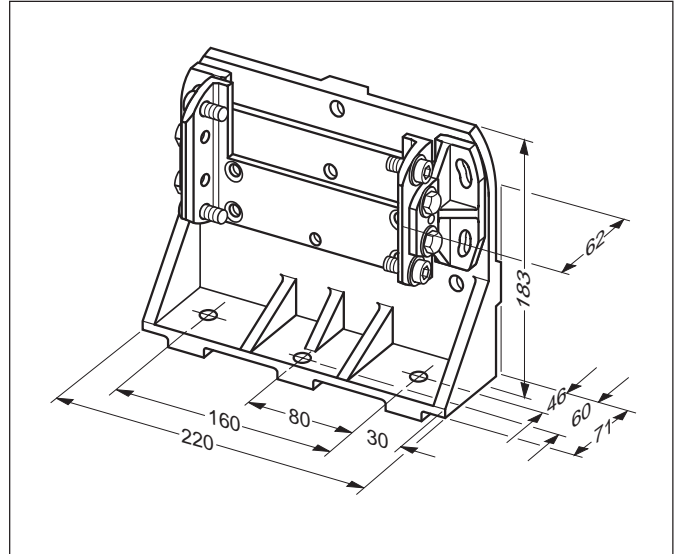

(All dimensions in mm)

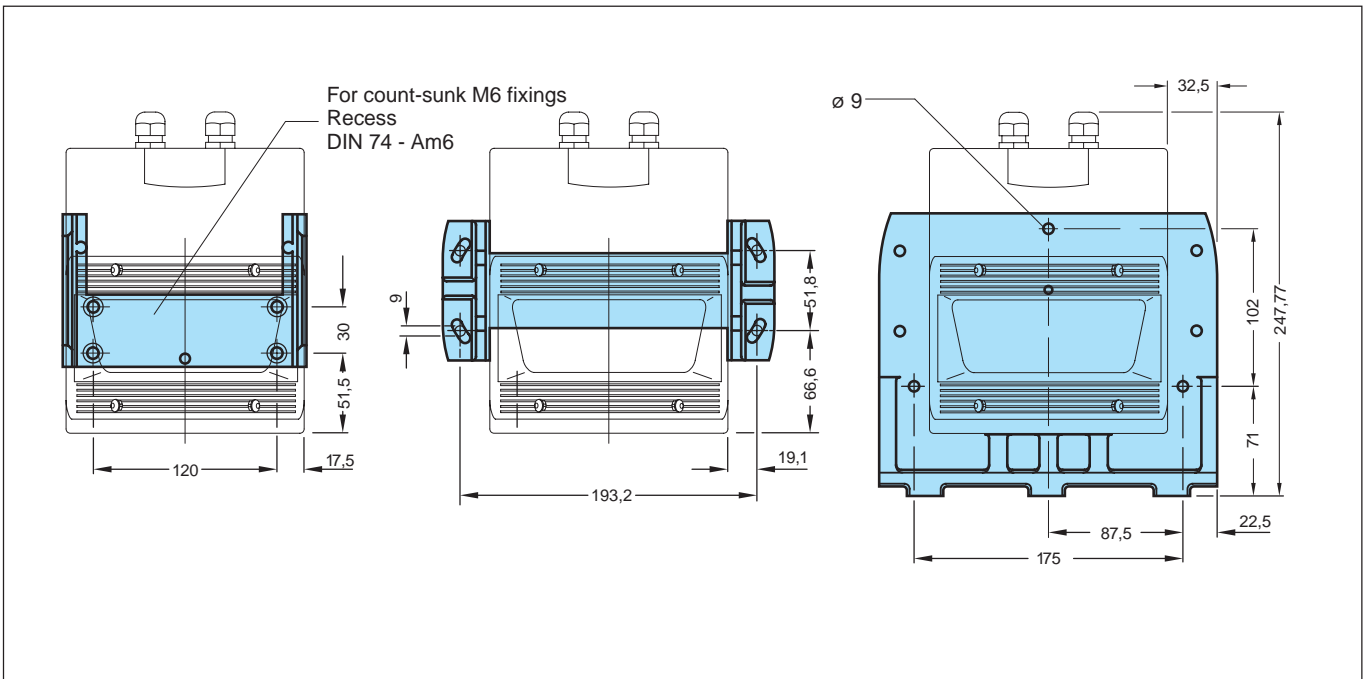

(All dimensions in mm)

8 Connecting Up the PLS

The PLS is supplied with two plug-in connection boxes for the power supply and interface. The electrical contact in each case is made by a 9-pin sub-D connector screwed into the connection box.

Only when both connection boxes, with their seals under them, are inserted flush with the housing and fixed with the side fixing screws does the PLS conform to protection class IP65. If the interface is not used, the dummy plug must be fitted.

You can order pre-assembled connection sets in which the power connector is fitted with an upward-routed cable. You will find more details on the available connection sets in the Appendix under "Accessories".

If you assemble the connection yourself, you can choose whether the connecting cable is routed out of the connector housing upward or to the rear. The unused threaded hole in either case must be plugged with a dummy plug.

Notes:

Lay all wires and connecting cables such that they are protected against damage.

If you are using the PLS to protect hazardous areas: make sure that the connected controller and all other devices also have the necessary safety level!

Make sure the connectors for the power supply and the interface are not mixed up when assembling the cable sets.

Do not drop the connectors. The sub-D connector could be pushed into the housing as a result.

- Check that the seals sit firmly on the connectors.
- Insert the connectors right-side up into the receptacles in the PLS housing. Push the connectors lightly into the housing. You will know that a proper connection has been made if the connectors terminate flush on the housing.
- Only then should you secure the connectors with the hexagon socket screws on the sides.

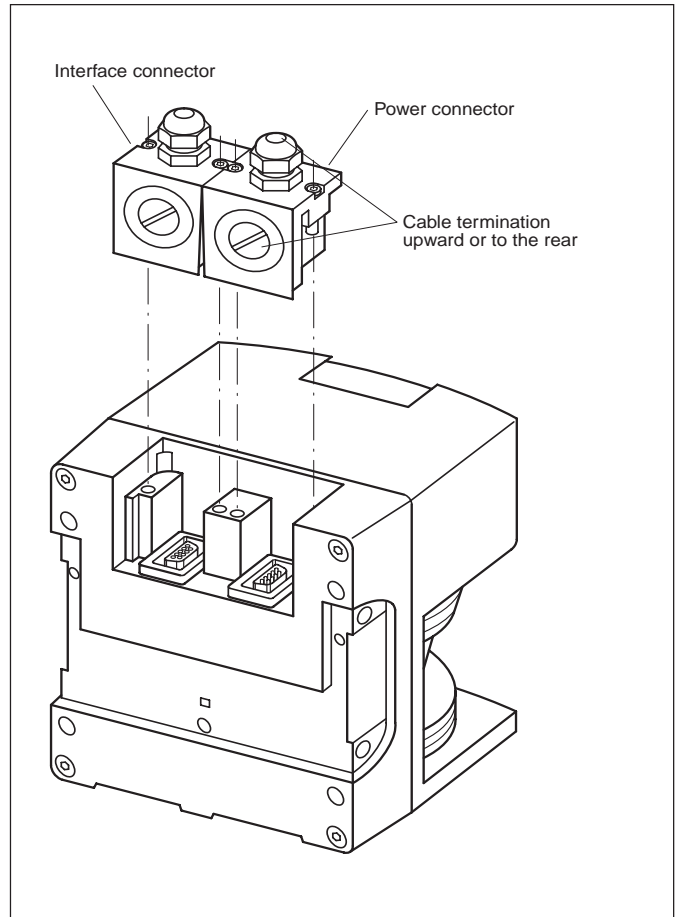

Connecting up the PLS

Connecting the power connector

The PLS requires a D. C. voltage of 24 V for its power supply. You will find more details on this in the Appendix under “Technical data”.

The power connector must have the following terminals:

- VCC_EXT and GND_EXT: A 24 V DC power pack to deliver the power
- RESTART: The restart button to release the PLS after a protective field infringement
- OSSD1 and OSSD2: The two protective semiconductor outputs which safely activate when the protective field is infringed
- WEAK SIGNAL: An additional output which activates optionally in case of dirt contamination of the front screen or infringement of the warning field, or both. If the PLS detects an error in its routine self-test, the output activates 4 times per second (see section 10: “LEDs on the PLS”).

Note:

If you connect loads such as lamps directly to the semiconductor outputs, you must pay attention to the following points:

- As a result of the initial resistance of a load (such as a lamp) the maximum permissible current rating of the outputs must not be exceeded, as otherwise the outputs’ current limiter will be activated.
- The loads must exhibit low-pass behavior ($f_g > 500$ Hz) so that the test pulses monitoring the outputs do not cause a shutdown.
- The maximum capacitive load is 100 nF. This must be observed in particular when using downstream safety modules.

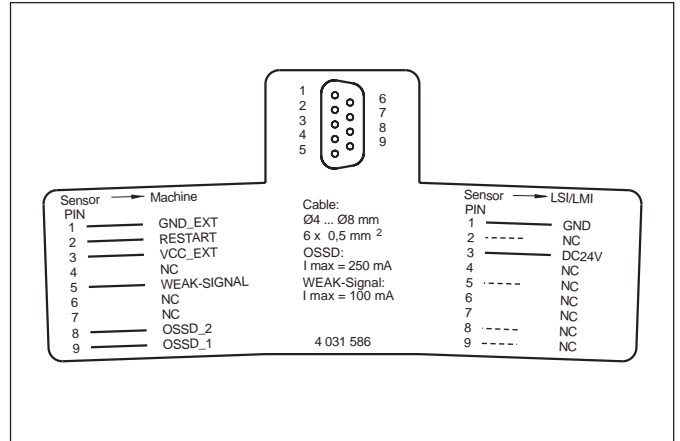

Power connector for PLS type 101-312 and for PLS types 101-112 and 101-212

Pin no.	Signal designation	Wire colours
1	GND_EXT (Ground)	brown
2	RESTART	blue
3	VCC_EXT (24 V DC)	red
4	NC	—
5	WEAK-SIGNAL (contamination signal or warning field infringed)	grey
6	NC	—
7	NC	—
8	OSSD_2 (protective output 2)	turquoise
9	OSSD_1 (protective output 1)	orange

Power connector: Wire colours

Connection examples

You need to connect the power connector pins differently depending on application.

The following pages give examples of various applications.

If you want to use one or more PLS together with a LSI (Laser Scanner Interface), you will find relevant connection examples in the technical description of the LSI.

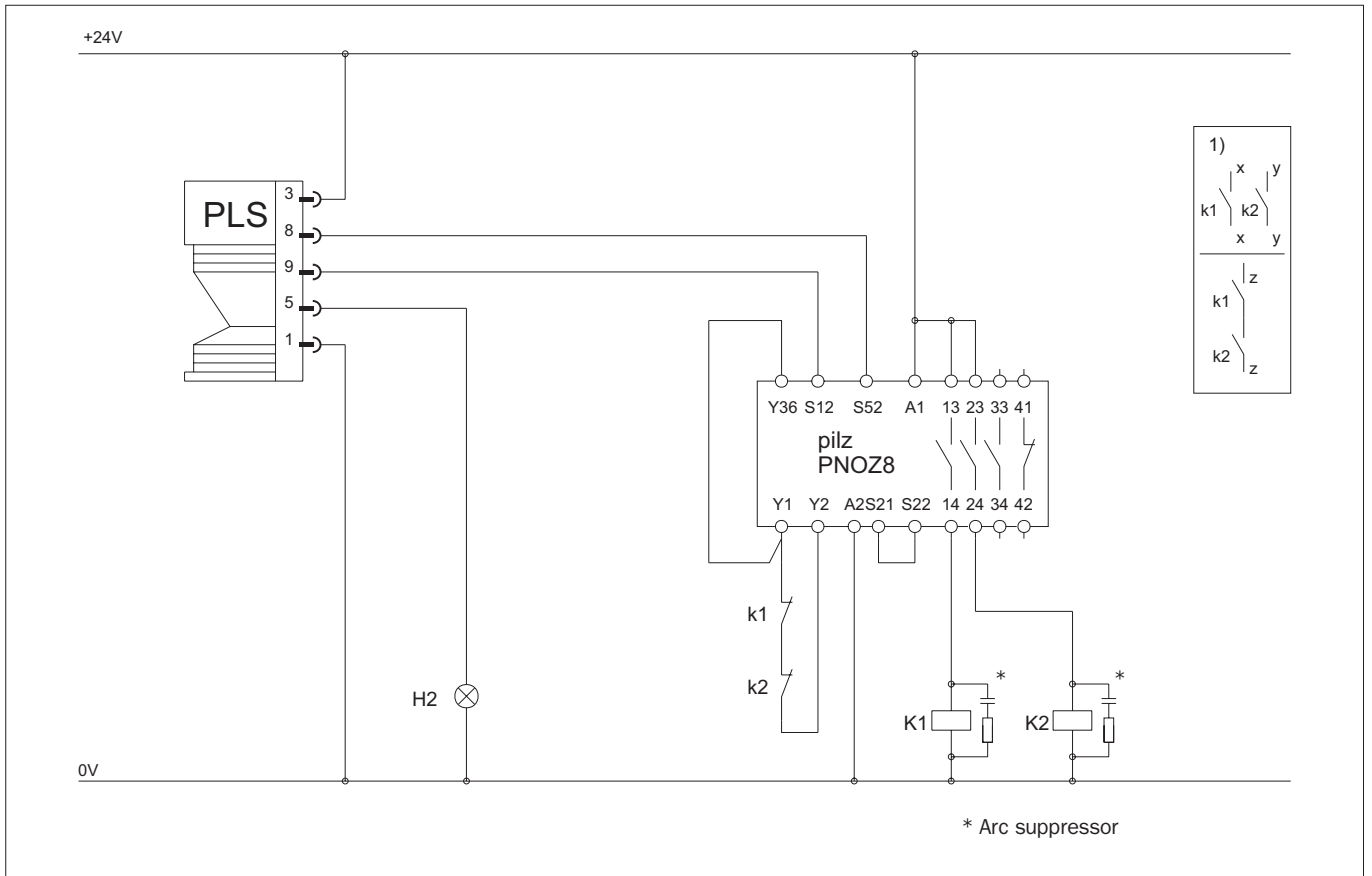

PNOZ 8 / Without restart inhibit, with contact monitoring

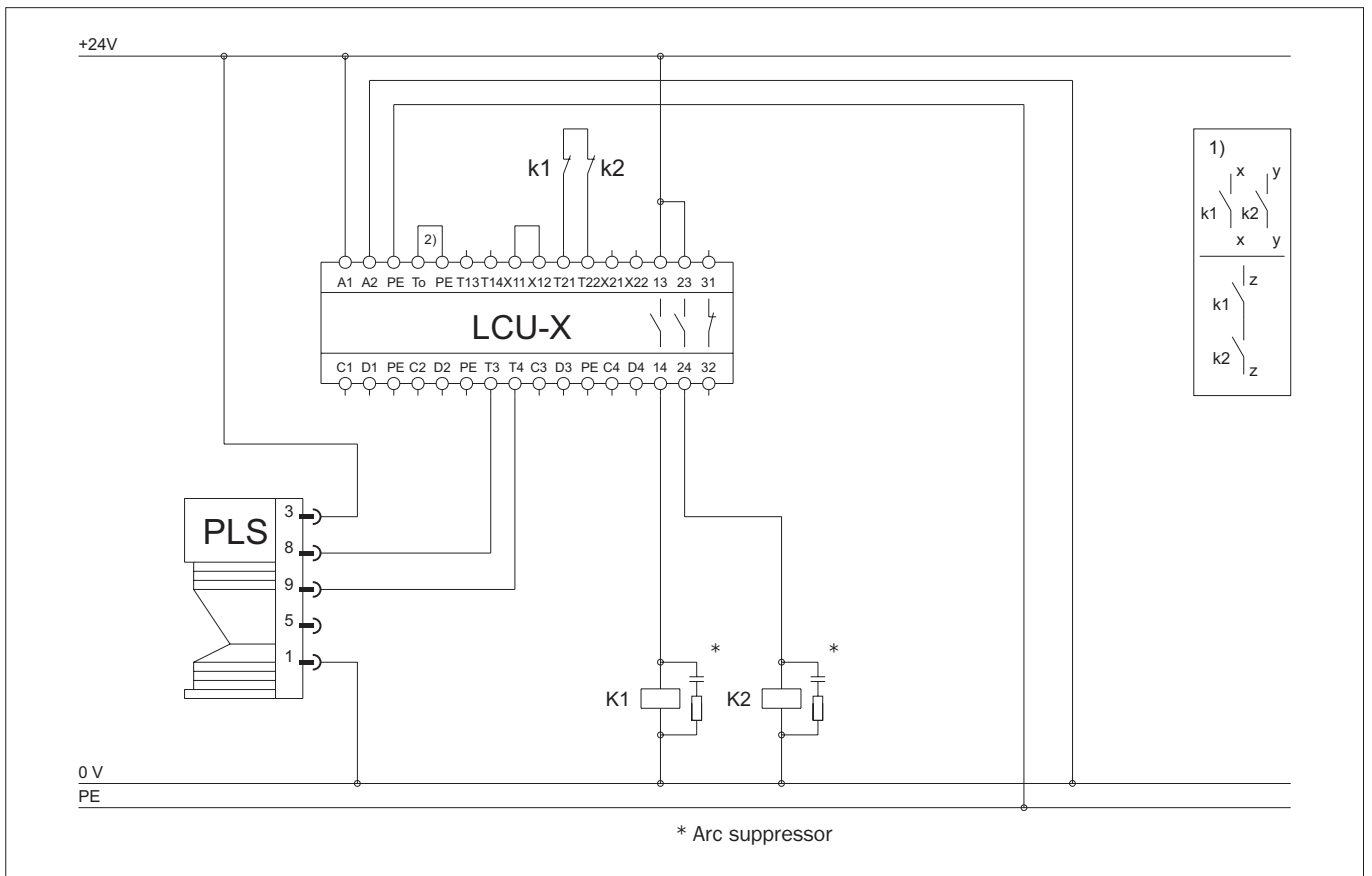

LCU-X / Protective operation without restart inhibit, with contact monitoring

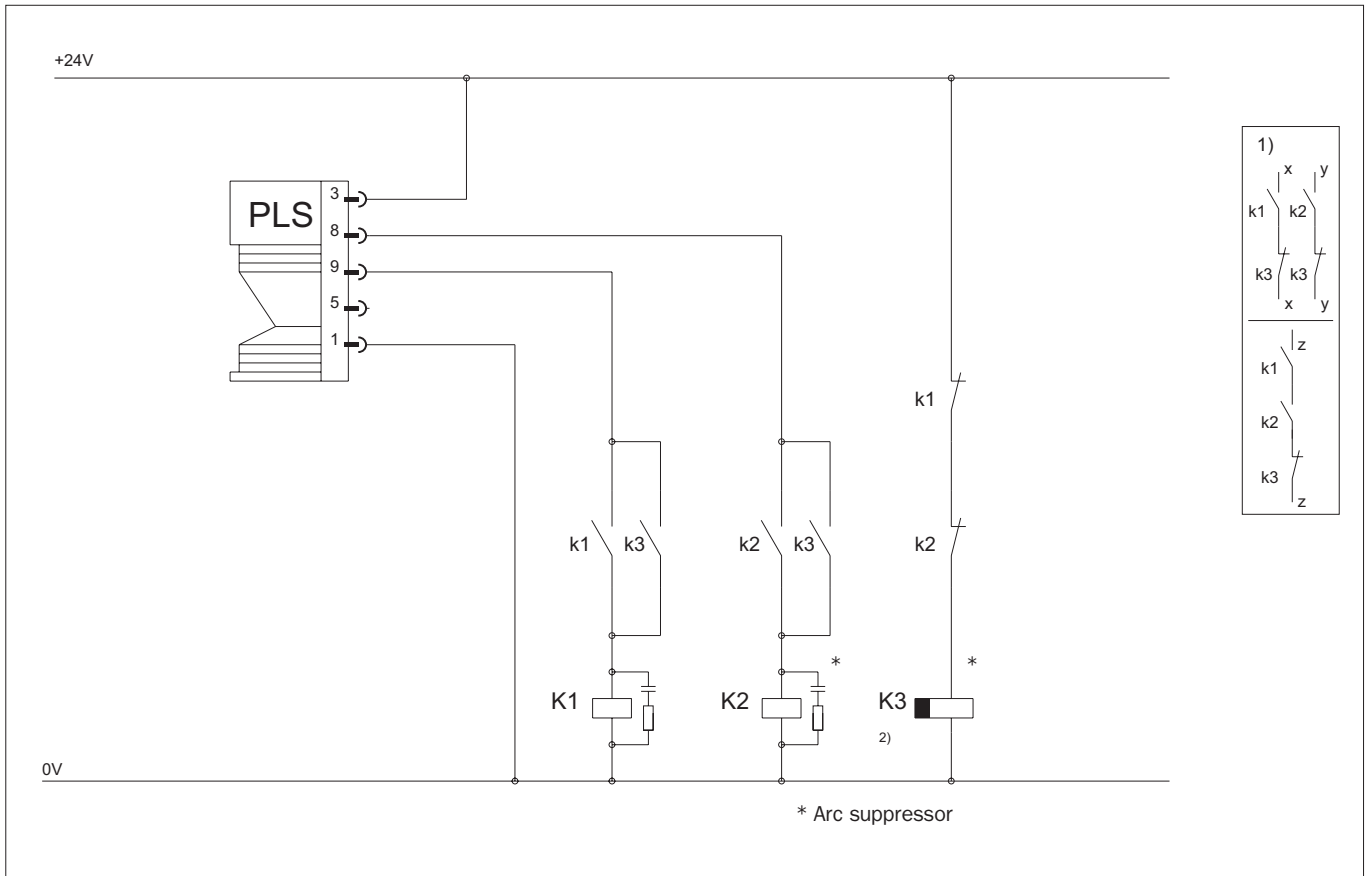

Evaluation of PLS outputs by relay with positively-driven contacts, mode: without restart inhibit

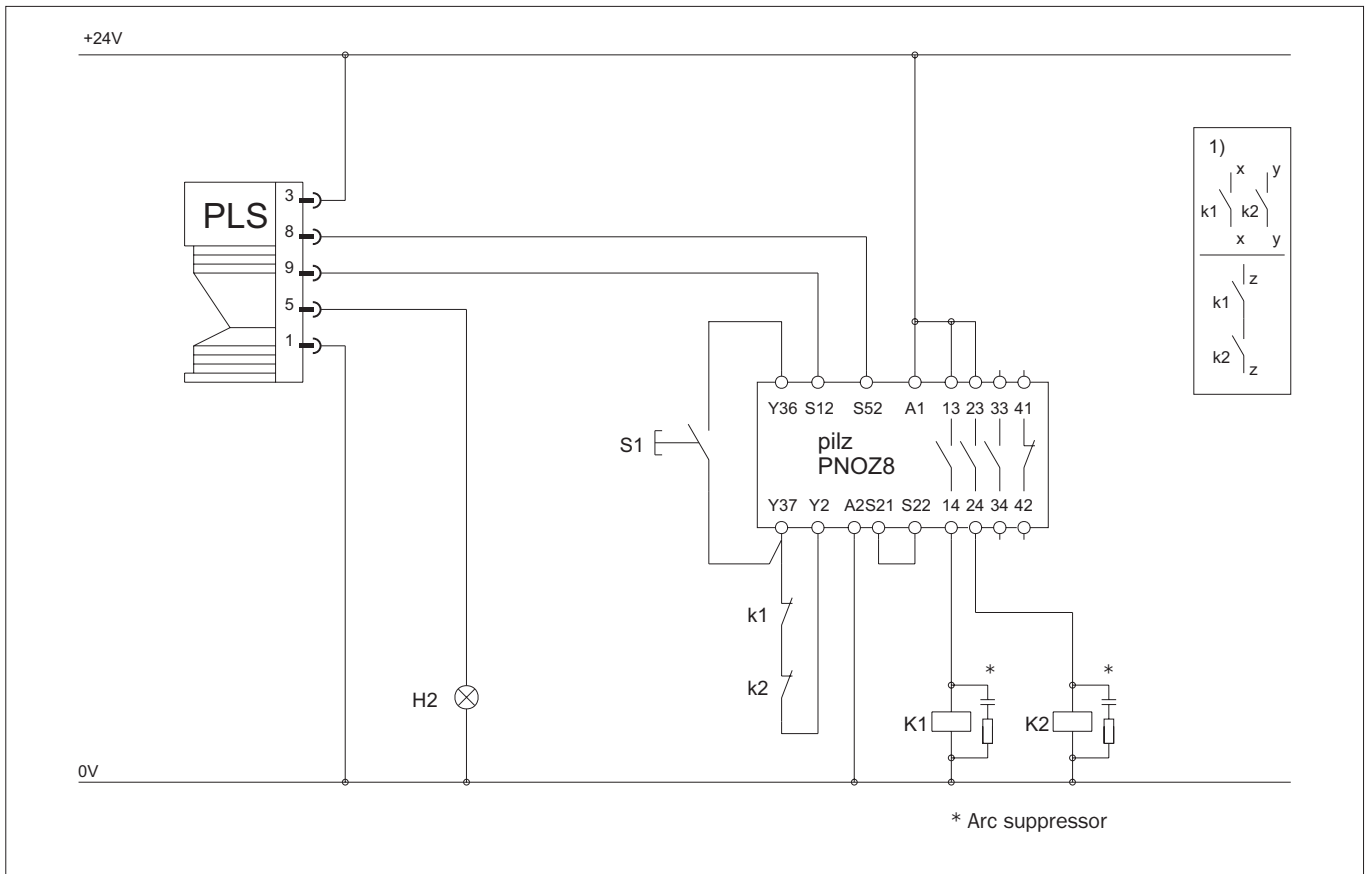

PNOZ 8 / With restart inhibit and contact monitoring

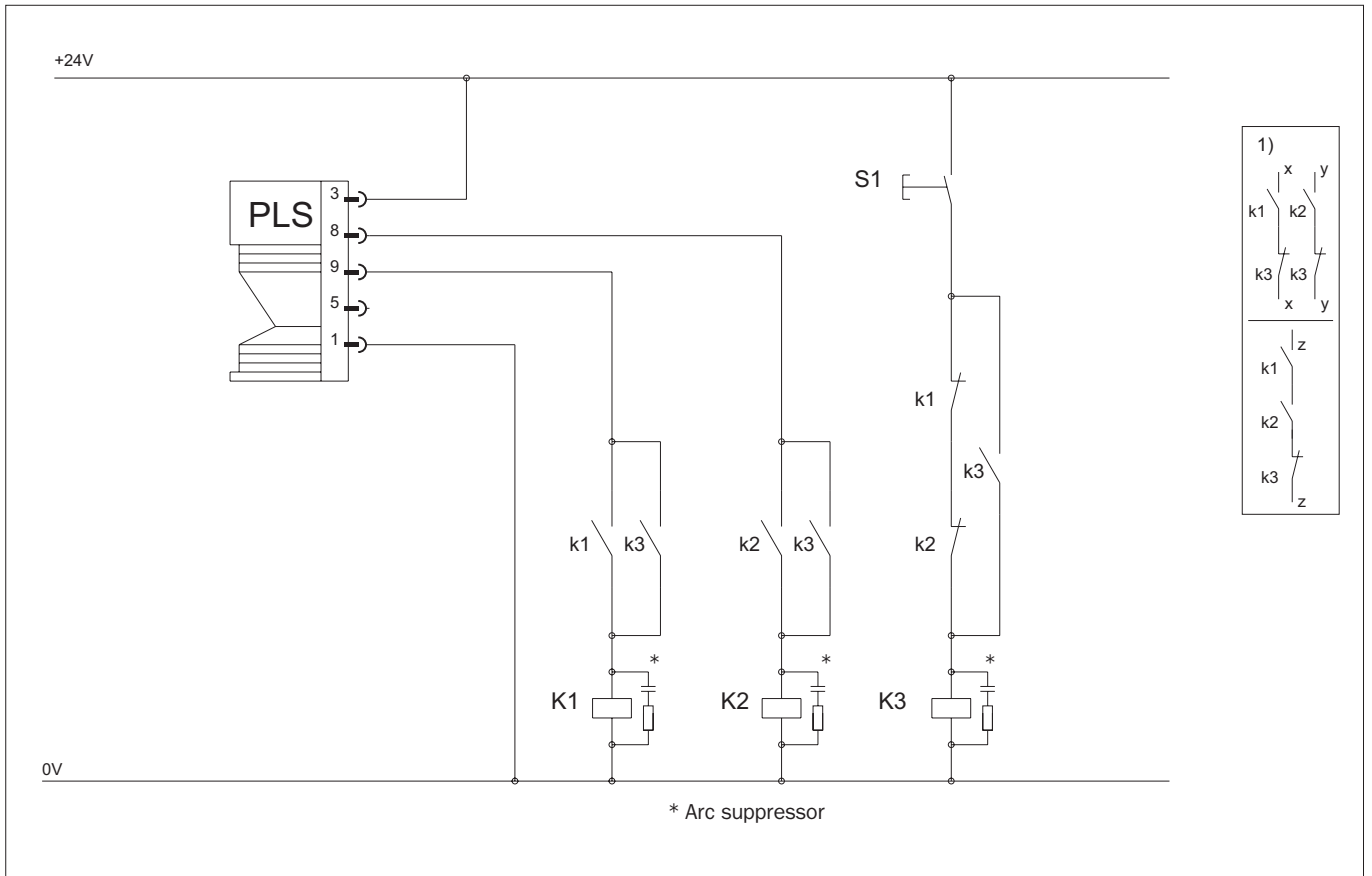

Evaluation of PLS outputs by relay with positively-driven contacts, mode: with restart inhibit

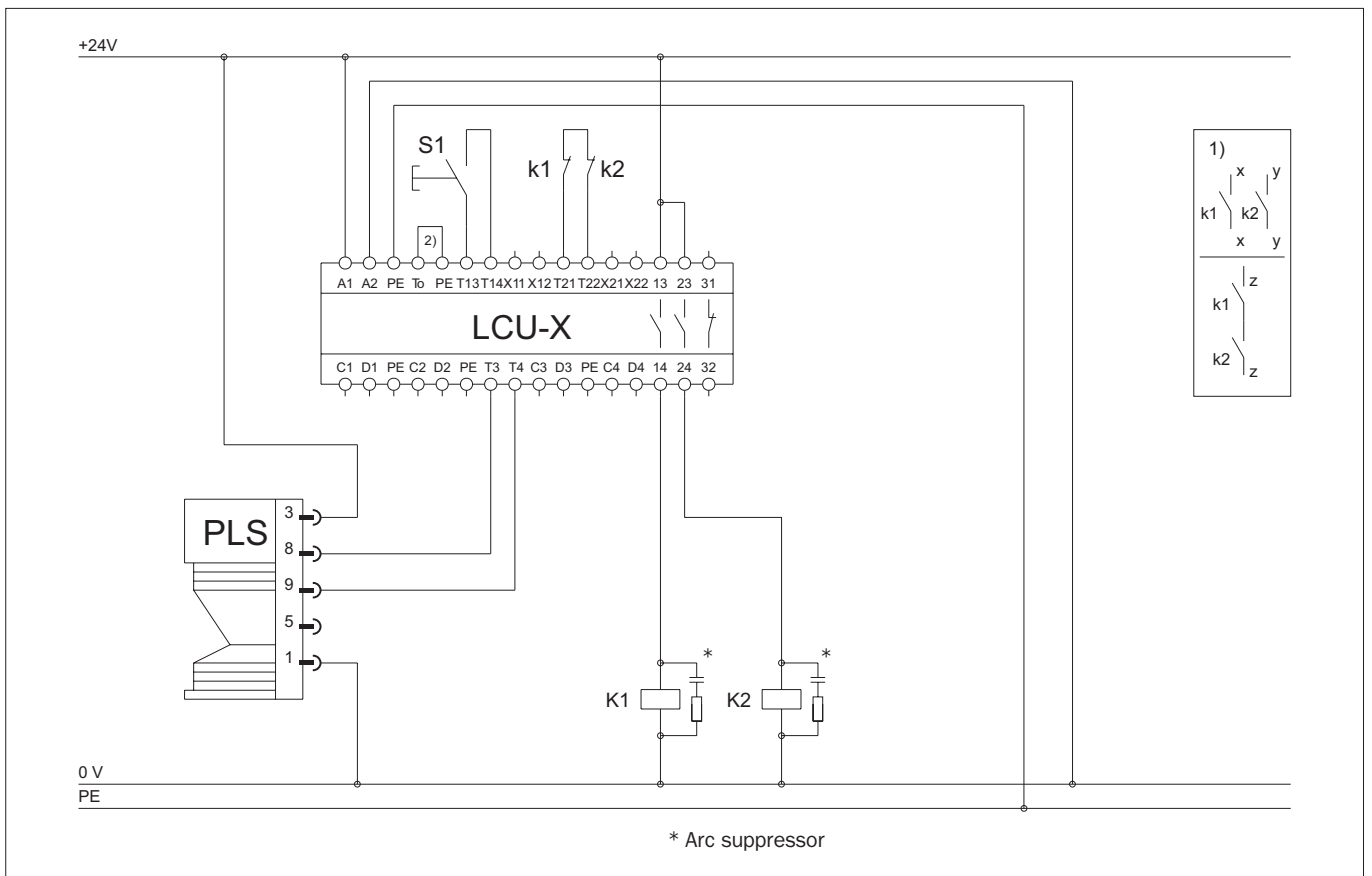

LCU-X / Protective operation with restart inhibit and contact monitoring

Notes

Note:

Use only relays with positively-driven contacts. The RC elements switched in parallel with the contactors are for arc suppression.

- 1) Output circuits. These contacts are to be inserted into the control such that, when the output circuit is opened, the hazardous state is eliminated. In categories 4 and 3 to EN 954-1 this insertion must be in two channels (x, y paths). Single-channel insertion into the control (z path) is only possible with single-channel control and taking account of the risk analysis.
- 2) To safeguard activation of K1 and K2 during the switchover phase, K3 should be executed with a release delay in accordance with the contactors used and the operating voltage.

The control circuits must be provided with a selective over-current protection device (fuse).

Important:

Use only relays with positively-driven contacts!

Connecting the interface connector

PLS type PLS 101-312 has a universal interface. Unmodified, it operates as a RS 232 interface and so can be connected to standard computers without problem.

Where long cable lengths (over 15 metres) or high data transfer rates are required, you can modify the interface into a RS 422 interface. There are two ways of doing this: Either jumper pins 7 and 8, or use the RS 422 interface cables, which already include the jumper (see the "Accessories" section in the Appendix).

PLS types PLS 101-112 and 101-212 do not have this switch option, and so can only be operated with the one specified interface.

When self-assembling the cables, make sure the shielding is attached on both sides.

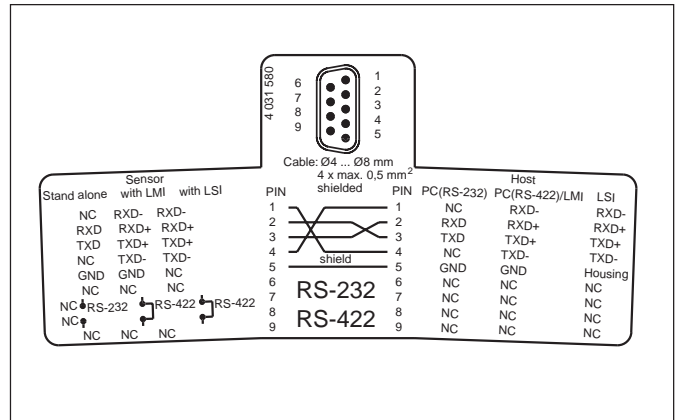

Interface connector for PLS type 101-312

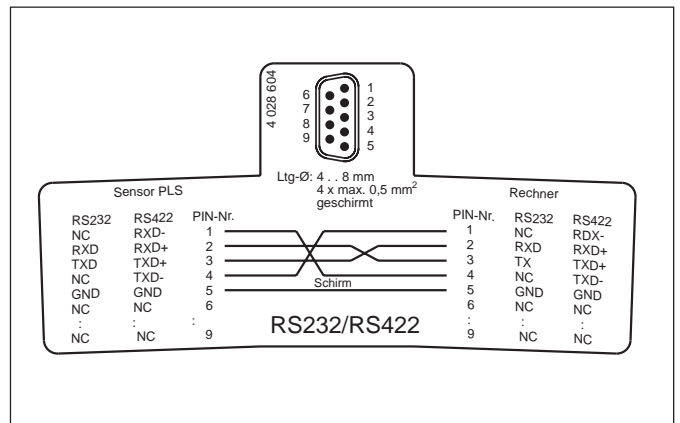

Interface connector for PLS types 101-112 and 101-212

Short-term connection to a PC

You normally only connect the PC to the sensor for programming purposes, for example when using the sensor to protect a hazardous area. All settings and fields remain stored in the sensor after the PLS is disconnected from the PC, until changed again by you. The sensor will not lose its data even in the event of a power failure!

To connect to the PC, use an interface cable (refer to the Appendix under "Accessories").

Note:

If you want to connect a sensor to a computer by a RS 422 interface, you must use a suitable cable. Refer to the notes on switching interfaces on the previous page.

- Remove the connection box over the interface socket on the PLS.

Note:

When the connection box has been released the PLS conforms only to protection class IP 40.

- Connect the sensor interface to the PC.
- Program the PLS. For detailed information refer to the user software description as from section 9.
- Detach the interface cable from the PLS.
- Reconnect the connection box and screw it in tight.

Note:

The pin assignment of a RS 422 interface is not standardized. Compare the pin assignment of the connecting cable with the one on the PC and adapt it accordingly.

Permanent connection to an evaluation computer

If you want to evaluate the measurement data of the PLS on a continuous basis, for example to navigate a vehicle, you must connect the PLS permanently to an evaluation computer (PLS 101-31x only).

- Wire the 9-pin sub-D connector in the connection box with a suitable cable (RS 232 standard, RS 422 twisted pair). You can choose whether to route the cable out of the box upward or to the rear.

Note:

The cable outlet is PG 9 size, and is suitable for all cable diameters from 4 to 8 mm.

- Plug the connection box into the PLS and screw it in tight.
- Lay the cable permanently to the evaluation computer or to the vehicle's on-board computer.

Note:

Lay all cables such that they are protected against damage.

9 Programming the PLS with the User Software

9.1 Installing the user software

Note:

This section describes how to program a PLS proximity laser scanner.

If you want to deploy one or more PLS together with a SICK LSI (Laser Scanner Interface), refer instead to the technical description of the LSI, section 9: "Programming the LSI with the User Software".

The SICK user software as from version 3.20 can be used to program the PLS or PLS/LSI systems.

If you have older SICK user software installed on your PC which you want to continue using, specify a different program directory/folder when installing the new PLS/LSI software.

System requirements

- min. 80486 processor
- min. 4 MB RAM
- min. 4 MB available hard disk capacity
- MS-Windows™ (version 3.1 or higher) or Windows 95™
- Colour monitor recommended

When installing your SICK user software you are guided by the installation program. You only need to start the installation program:

- Boot your PC.
- Insert the PLS/LSI program disk in your PC's floppy drive.
- **Under Windows:**
Choose from the File Manager **File – Run**.
- **Under Windows 95:**
Choose **Run** from the Start menu.
- Select and run "Install.exe".
- As necessary, enter the program directory/folder where you want the new PLS user software to be installed.
- Follow the on-screen instructions.

When the installation is finished a message box appears telling you that the setup has been completed successfully.

The PLS user software is now installed. You can run it any time by clicking on its icon.

9.2 What to do

Note:

When the program starts you are automatically logged on as the machine operator. As such, you can poll data but cannot transmit any.

To be able to transmit configuration data and monitoring areas to the PLS, you must log on as an "Authorized Client". How to log on is described in section 9.3.

Essential steps

In creating a new configuration you are guided by the user software. It guides you through the following steps:

- **Configure hardware:**
You log the PLS on and define the restart inhibit mode of the output. You select the number of multiple evaluations and define whether you are using the sensor for area protection or for protection on a vehicle. You also define the switching behavior of the "Weak Signal" output.
- **Define monitoring range:**
You define the range to be monitored by the PLS. If you wish, you can also determine the shape and size of the protective field and warning field here.
- **Send configuration to PLS:**
You now transmit all the configuration settings you have made to the PLS. You must be logged on as an "Authorized Client" to be able to do this.
- **Edit monitoring range:**
Here, if you wish, you have the chance to alter the shape and size of the protective field and warning field.
- **Send monitoring range to PLS:**
Finally you transmit the protective field and warning field to the PLS. For this too, you must be logged on as an "Authorized Client".

When you have completed these steps the PLS system is ready for operation.

Note:

Change the logon password, to protect your PLS system against manipulation (see section 9.13).

Log your configuration data stored in the PLS, and back up the configuration on the hard disk or on a floppy (see section 9.12).

Other options

In addition to the essential steps, you can use a number of other options when configuring your PLS system.

- **Edit fields:**
To edit the protective and warnings fields the user software provides you with a number of useful edit functions.
- **Teach-in and check protective field:**
In the teach-in process you run over the contours of the desired protective field with the sensor active, and the PLS stores the learned contour. You have to check learned protective fields.
You can also edit a learned protective field subsequently, just like any other segmented field.
- **Monitor protective field:**
You can monitor the protective field and warning field in operation using a connected PC. You can also store the defined space contours of the sensor as a check.
- **Check settings:**
You can view, check and print all configuration settings in a page view.
- **Receive and store configuration:**
You can receive and print the configuration data stored in the PLS. You can save any configuration to the hard disk or to a floppy.
- **Change password:**
To protect your PLS against manipulation, you should change the logon password.
- **Change screen view:**
You can zoom, unzoom or move the screen view, for example.
- **Interrogate fault memory (system diagnosis):**
For troubleshooting purposes you can interrogate the fault memory of the PLS.

9.3 Entry: The initial configuration

The PLS is shipped with certain pre-configured settings. This section describes how you can adapt those settings to your application.

- Switch on your PLS system (it takes a few seconds to start up).
- Start the user software.

The following dialog box appears:

- Click on “Yes”.

The PC receives the pre-configured settings and displays them on-screen.

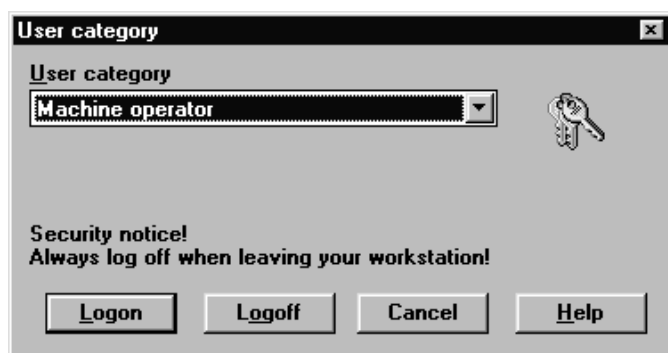

This dialog box appears.

To be able to send the configuration and monitoring area to the PLS, you must log on as an “Authorized Client”.

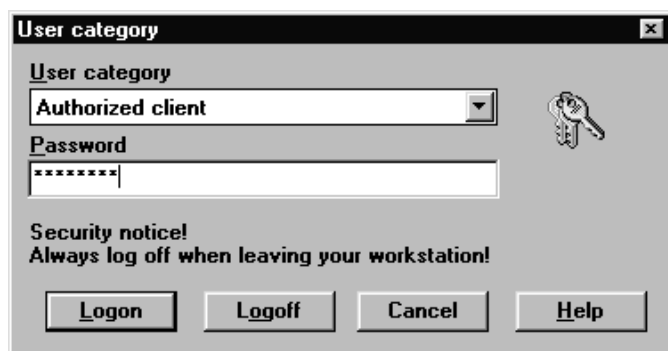

- Choose “Authorized Client” from the category list.
- Enter the password “SICK_PLS” and click on “Logon”.

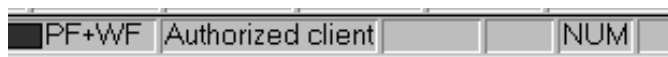

You are now logged on as an “Authorized Client” (see status bar at bottom of screen).

Note:

Always log off when leaving your workstation! This will prevent unauthorized persons from manipulating your PLS system.

Configure hardware

You can edit the received configuration or create a new one.

To create a new configuration:

- From the menu choose **File – New** and click on “PLS Configuration”.
- Click on “OK”.

This dialog box appears. This is where you set the sensor type you want to work with.

- Select your sensor type or have the sensor automatically detected by clicking on “Detect”.
- Click on “Continue”.

The remaining steps to follow and dialog boxes which appear are the same as the following steps under “Edit configuration”.

To edit the received configuration:

- From the menu choose **PLS – Configuration – Edit**.
- Or choose the “Edit Configuration” button from the toolbar.

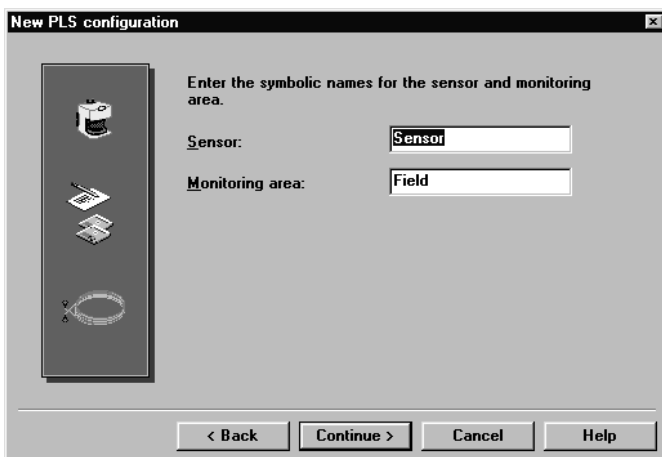
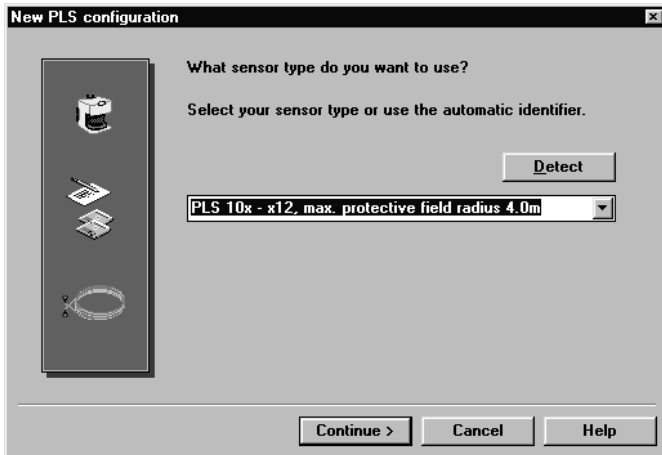

This dialog box appears. Here you can enter a symbolic name for the sensor and the monitoring range.

- Enter a name for the sensor and the monitoring range. These names have no functional significance, they are only intended as an aid to better allocation.
- Click on “Continue”.

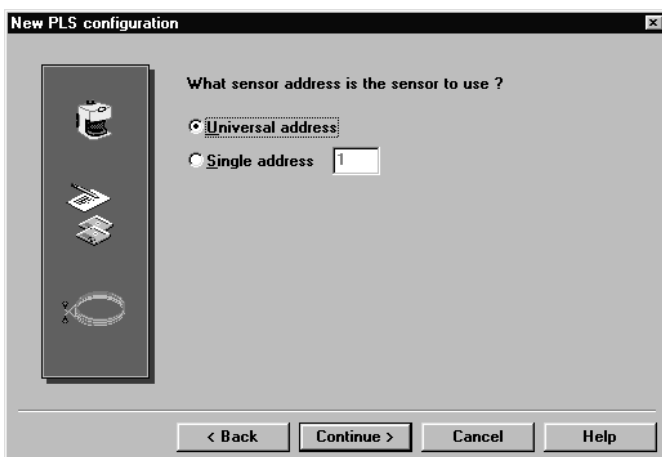

This dialog box appears. This is where you set the address under which the PLS is to be addressed.

- Select whether you want to use a universal or single address.

Universal address (zero):

This is the recommended setting. If you set “Universal address”, the stored configuration can be transferred at a later time to any other PLS.

Single address (between 1 and 99):

If you set “Single address” you assign the PLS the address specified here for transferring the configuration. It is then only possible to reload a configuration at a later time if the address specified here and the one stored in the PLS match.

This makes sense when you want to ensure that a configuration saved as a file can only be transmitted to specific PLS units.

- Click on “Continue”.

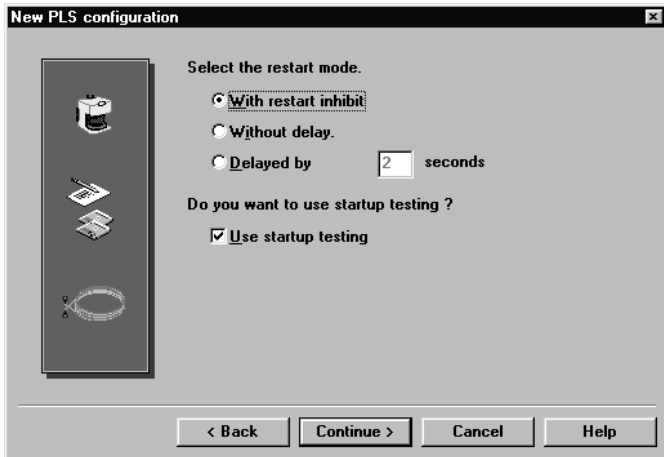

This dialog box appears. This is where you set the restart behavior of the output and the startup testing.

- Select how the PLS is to restart after a protective field infringement.
 - With restart inhibit:**
The system only restarts after a protective field infringement or a reset when the protective field is free and the restart button is pressed.
 - Without delay:**
The system restarts immediately as soon as the protective field is free.
 - Delayed by n seconds:**
The system only restarts when the time set here has elapsed after the protective field has become free again.
- Check the checkbox for whether you want startup testing. If you select this option, you must intentionally interrupt the protective field one time after switching on the system. Only then is the system ready for operation.
- Click on "Continue".

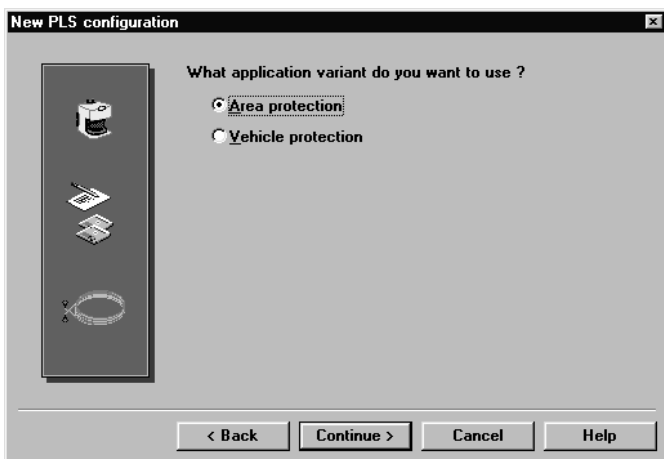

This dialog box appears. This is where you define the field of application of your PLS system.

- Select whether you want to use the PLS for area protection or for protection on a vehicle.
- Click on "Continue".

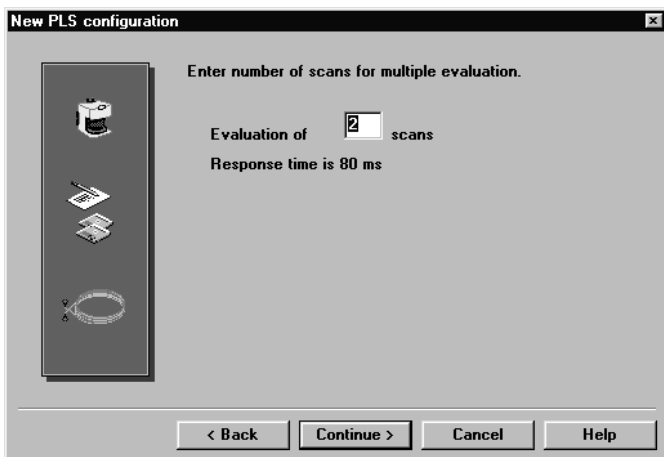

This dialog box appears. This is where you set how often (that is, in how many consecutive scans) the sensor must detect a foreign body in the protective field before it signals an infringement (between 2 and 16 scans are possible).

- Enter the desired number of scans.
 - Note:**
For safety reasons, always select the lowest possible setting! If you increase the setting the system will become more stable, but will also respond more slowly. In this way you can achieve a good level of availability in an environment with a high dust concentration, for example. The current response time is shown in the box.
- Click on "Continue".

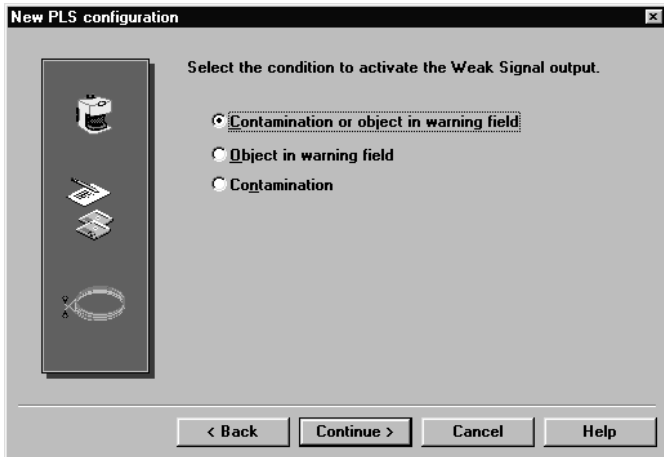

This dialog box appears. This is where you set when the “Weak Signal” output is to activate.

- Select the desired condition:
 - Contamination of front screen or object in warning field
 - Object in warning field
 - Contamination of front screen
- Click on “Continue”.

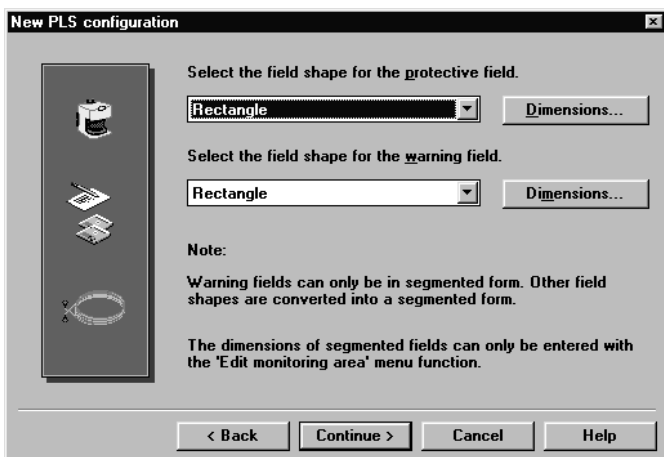

If you create a new configuration this dialog box appears. This is where you define the monitoring range.

- Select the shape of the protective field and warning field. You can define the sizes of the fields now or later. If you want to define them now, click on “Dimensions” and enter the dimensions you want.

Note:

You will find more details on editing the protective field and warning field in section 9.4.

- Click on “Continue”.

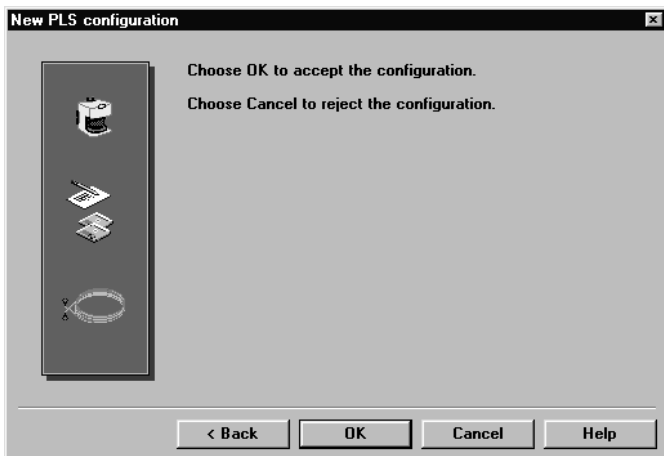

- Click on “OK” to accept the configuration.

The configuration is defined. You can now transmit the settings to the PLS, as described in the following section.

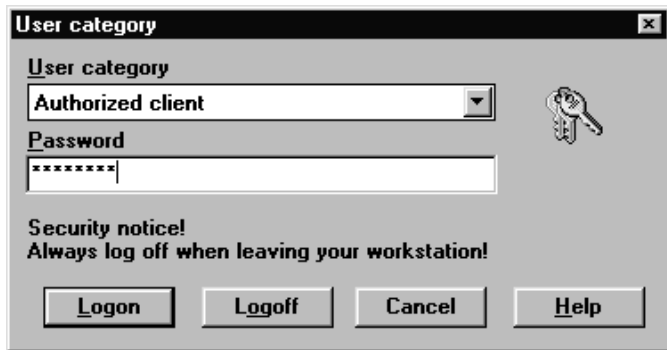
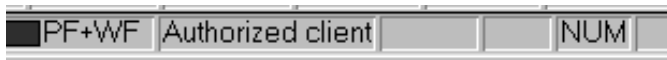

Send configuration to PLS

- Make sure you are logged on as an “Authorized Client” (see status bar at bottom of screen).
- If you are not logged on as an “Authorized Client”, choose **PLS – User Category** from the menu, or click on the “Logon/Logoff User Category” button on the toolbar.

This dialog box appears.

- Choose “Authorized Client” from the list of user categories.
- Enter the password “SICK_PLS” and click on “Logon”.

You are now logged on and can send data to the PLS.

- From the menu choose **PLS – Configuration – Send to PLS** from the menu, or click on the “Send Configuration” button on the toolbar.

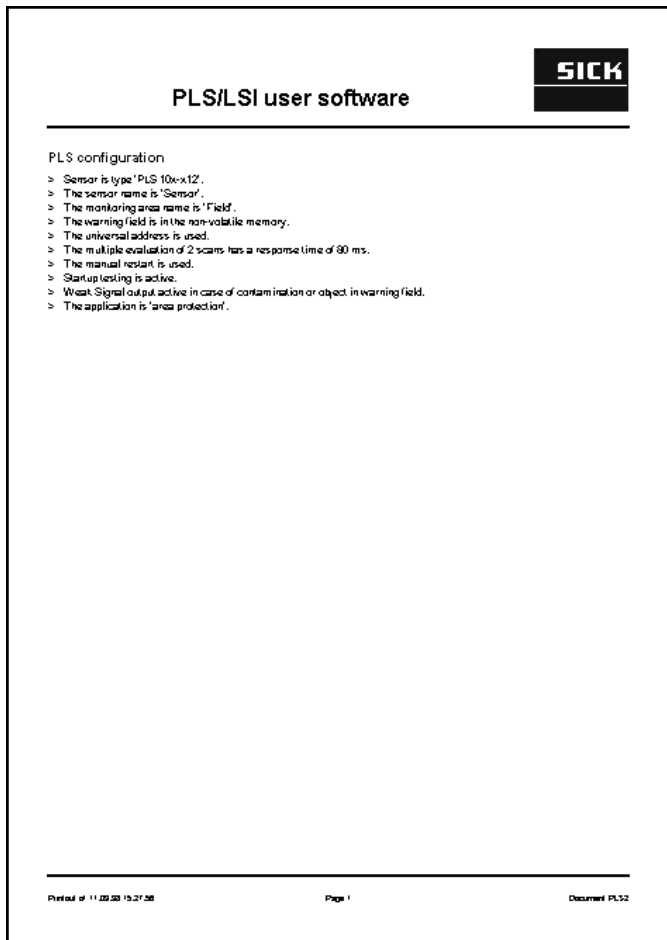

The screen displays an overview of the configuration settings for you to check through once again.

To correct settings:

- Click on “Cancel” to close the overview and change the settings.

To confirm settings:

- Click on “Confirm”.

The configuration data are sent to the PLS and stored there.

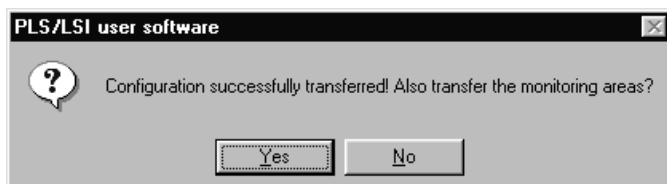

This dialog box appears.

- If you want to transmit the monitoring ranges unchanged, click on “Yes”. You can then skip the next section, “Edit monitoring range”.
- If you also want to alter the shape and size of the monitoring ranges, click on “No”. You can then edit the protective and warning fields, as described in the following section.



Edit monitoring range

The screen displays the protective field you have defined. You can edit the size of the protective field and the warning field after defining them.

- From the menu choose **Monitoring Range – Edit** from the menu, or click on the “Edit Monitoring Range” button on the toolbar.
- From the “Active Field” list select the protective field or warning field you want to edit.
- From the “Active Background Field” list select the protective field or warning field that you want to see in the background for comparison purposes.

The selected fields and the space contour of the sensor are shown on-screen.

Convert field shape:

- To convert a field into a different shape, choose **Edit – Convert Into** from the menu.

Three different field shapes are available to choose from:

- Rectangle: This is the default. Newly defined fields are always this shape, unless you select a different setting. You can adjust the height of the rectangle and the width at the right and left.
- Semicircle: Here you define the radius.
- Segmented field: You can select various resolutions. The more segments a field has, the higher is its resolution. You can define the coordinates for each segment individually.

Notes:

Warning fields are always segmented fields. If you have defined a warning field as a rectangle or semicircle, it is automatically converted into a segmented field with the appropriate dimensions.

When you convert a field or change the resolution of a segmented field, the shape of the field may change minimally, but it is displayed on-screen.

The following sections set out only the basic means of defining the sizes of the various field shapes. For more information on editing fields, refer to section 9.4.

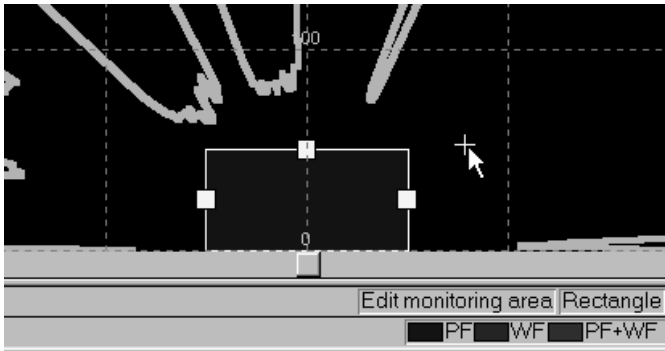

Define rectangular field:

- To set or move a corner point:
Double-click on the desired position with the mouse.

Note:

In the example a rectangular grid pattern was chosen for the screen view. You can switch between circular and rectangular grid patterns. For more details refer to section 9.14.

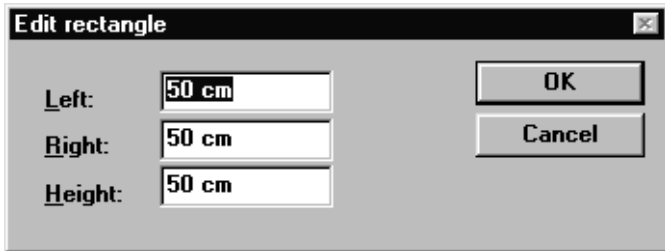

... or:

- From the menu choose **Edit – Field Coordinates**.

This dialog box appears, showing the dimensions of the rectangle.

- Enter the dimensions you want.
- Confirm with "OK".

The dimensions of the rectangle are changed accordingly.

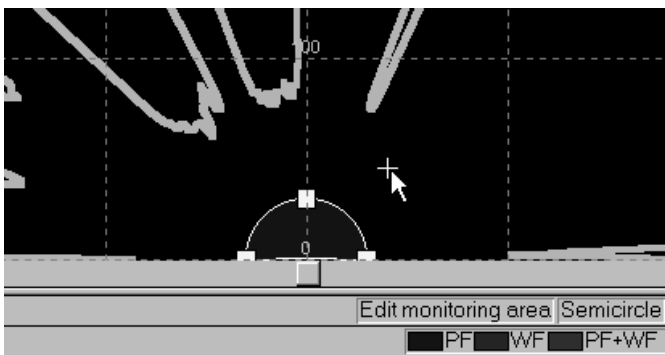

Define semicircle:

- Double-click with the mouse on the desired position to define the radius of the field.



... or:

- From the menu choose **Edit – Field Coordinates**.

This dialog box appears, showing the radius of the semicircle.

- Enter the dimension you want.
- Confirm with "OK".

The radius of the semicircle is changed accordingly.

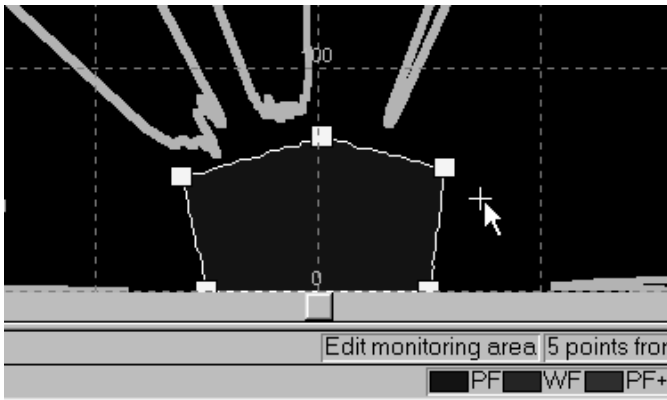

Define segmented field:

- To set a point with the mouse:
Double-click on the desired position.
- To move a point with the mouse:
Select the point and drag it to the desired position.
- To delete a point:
Select the point and click on the “Delete” button on the toolbar.

... or:

- From the menu choose **Edit – Field Coordinates**.

This dialog box appears, showing the coordinates of all defined points. You can add any points to the list, or you can select a point and edit it or remove it.

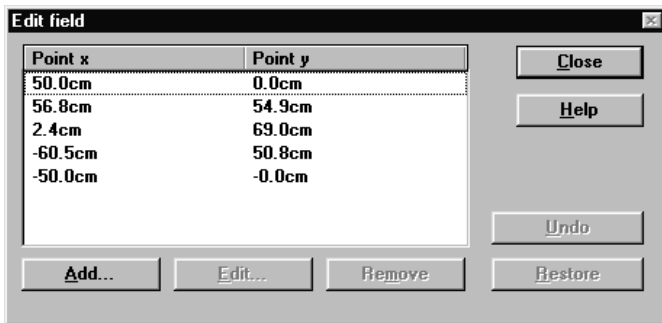

- To set a point:
Click on the “Add” button and enter your desired coordinates in the dialog box.
- To move a point:
Select the point in the list and click on the “Edit” button. Enter your desired coordinates in the dialog box.
- To delete a point:
Select the point in the list and click on the “Remove” button.

Note:

You can also select a point with the mouse before choosing **Edit – Field Coordinates**. The coordinates of the point in question are then already highlighted in the list.

- When you have defined the protective and warning fields as you want, deactivate the **Monitoring Range – Edit** menu function,
or deactivate the “Edit Monitoring Range” button on the toolbar.

Note:

After programming, check on the plant or vehicle that the monitoring range is the correct size and shape! You can do this by intruding intentionally into the monitoring range.

This also applies where you upload a field from a floppy disk into the PLS.

Only start up the plant or vehicle when you are sure the monitoring range is operating effectively!

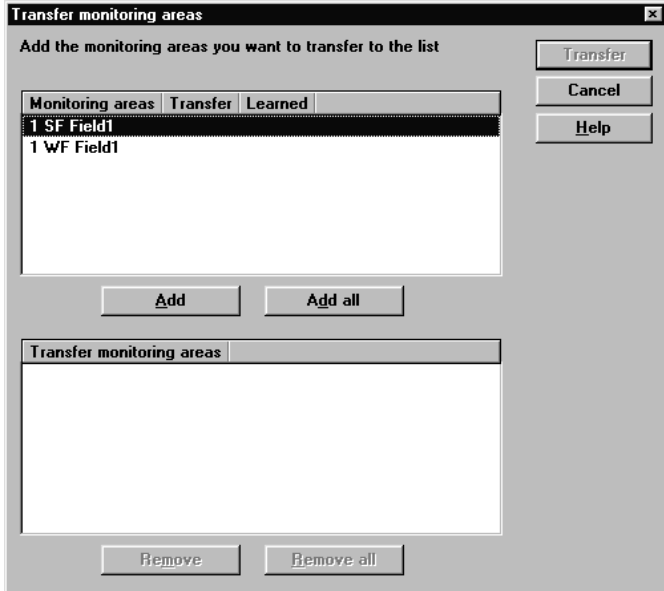

Send monitoring range to PLS

- From the menu choose **Monitoring Range – Send to PLS** from the menu, or click on the “Send Monitoring Range” button on the toolbar.

This dialog box appears.

- Click on “Add All”, or – if you only want to transmit individual fields – select the fields you want from the list at the top and click on “Add”.

The fields are entered in the list at the bottom.

- Click on “Send” and confirm for each individual field with “Yes” or “OK” as appropriate.

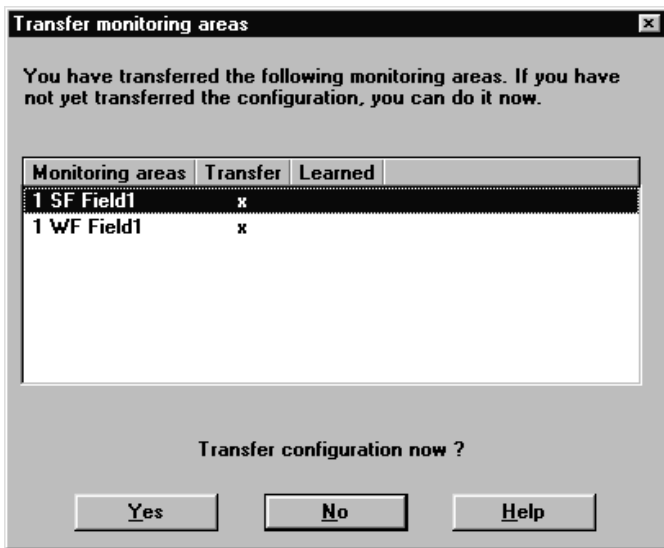

This dialog box appears. The transmitted fields are now marked with asterisks in the list.

- Check that protective fields and warning fields are marked with an asterisk, and so have been transmitted correctly.
- If you sent the configuration before, you can click on “No”. If you have not yet sent the configuration, click on “Yes” and transmit it as previously described under “Send configuration to PLS”.

When you have transmitted the configuration and the monitoring range, the system is ready for operation.

Note:

When leaving your workstation log off by way of the **PLS – User Category** menu function!

Also change the “Authorized Client” logon password. Make a note of the new password at a location accessible only to authorized persons. This will prevent unauthorized persons from manipulating the PLS system (how to change the password is described in section 9.13).

9.4 Edit/dimension fields

Section 9.3 describes the basic way to edit a protective field or warning field. You can use rectangular, semicircular or multiple-segmented fields. You can draw the fields using the mouse or type in their coordinates.

This section describes additional options of defining the size and shape of the protective and warning fields for your application. Various edit functions will assist you in drawing up the fields.

Note:

After programming, check on the plant or vehicle that the monitoring range is the correct size and shape! You can do this by intruding intentionally into the monitoring range. Only start up the plant or vehicle when you are sure the monitoring range is operating effectively!

Convert fields

You can convert a field into a different shape - for example, a rectangular field into a segmented field.

- From the menu choose **Edit – Convert Into**.

Three different field shapes are available to choose from:

- Rectangle: This is the default. Newly defined fields are always this shape, unless you select a different setting. You can adjust the height of the rectangle and the width at the right and left.
- Semicircle: Here you define the radius.
- Segmented field: You can select various resolutions. The more segments a field has, the higher is its resolution. You can define the coordinates for each segment individually.

Notes:

Note that during conversion slight deviations in the protective field coordinates can occur, which are nonetheless visible on-screen.

Warning fields are always segmented fields. If you have defined a warning field as a rectangle or semicircle, it is automatically converted into a segmented field with the appropriate dimensions.

Change scale of segmented field

When you have defined a segmented field you can enlarge or reduce it in scale.

- Choose **Edit – Select All** to select all the points in the field.
- Pick up one of the points with the mouse and drag the field to the size you want.

Each point is dragged on a measuring ray of the sensor away from or toward the zero as appropriate.

Copy and paste fields

You can copy fields to the clipboard and paste them at a different location. But you cannot mix field types: you can only paste a protective field back in as a protective field, and a warning field as a warning field.

- From the menu choose **Edit – Copy** to copy the current field to the clipboard.
- Choose **Edit – Paste** to paste the field from the clipboard.

You can then edit the field you have just pasted as normal.

Save individual fields

You can save individual fields as files so they are available to be used in other configurations.

- Choose **Edit – Copy To** and save the current field under the desired file name on the hard disk or on a floppy.
- To insert the stored field at the desired location, such as in another configuration, choose **Edit – Paste From** and enter the file name and storage location.

The field is inserted. You can then edit the field as normal.

Fix coordinates

When editing a segmented field you can fix one of the coordinates of a point. This may be necessary when the coordinate in question must not be changed, such as when configuring a protective field for a narrow alley.

- From the menu choose **Edit – Field Coordinates**.
- In the list select the point whose position you want to change and click on “Edit”.

This dialog box appears.

- Enter the coordinates you want for x and y.
- Select which coordinate must not deviate from the entered value, for example “Fix X-value”, and click on “Calculate”.

The next closest point on a measuring ray with the desired coordinates is calculated.

- The calculated coordinates are displayed. To accept them, click on “OK”.

Edit point

Position x: 28 cm

Position y: 8 cm

OK

Cancel

Calculation method

1) Standard 2) Fix X-value 3) Fix Y-value

The following values are accepted with OK:

Position x:

Position y:

Calculate

9.5 Teach-in protective field

You can teach-in protective fields. To do so, you run over the contours of the desired protective field with the sensor active, and the PLS stores the learned contour. You have to check learned protective fields.

You can also edit a learned protective field subsequently, just like any other segmented field.



- From the “Active Field” list select the protective field.
- From the menu choose **Monitoring Range – Teach-in**.
- Or click on the “Teach-in Monitoring Range” button on the toolbar.

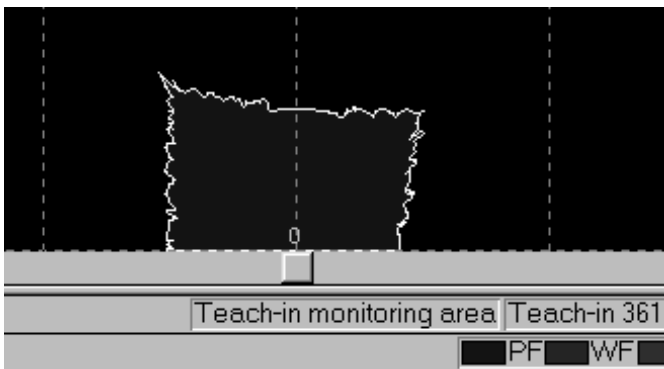

This dialog box appears. The protective field is represented on-screen as a coloured area.

The active sensor scans its surroundings and shows you the results. The contour you see on-screen is the largest possible extent of the protective field (the precise contour of the protective field is based on the ambient contours).

- If you want to reduce the size of the learned contour, run a target (e.g. a piece of cardboard, at least 10 x 10 cm in size) slowly along the edge of your desired protective field.

The contour of the protective field is reduced at the relevant point. On the screen you can track how the protective field takes on the taught-in contour.

Note:

Do prevent fixed obstacles in the scanning plane subsequently producing false signals, 13 cm (= max. measuring error of PLS) is automatically deducted from the learned contour. Take this into account as appropriate when running over the protective field. Also note that the teach-in process may result in an additional error of 4.5 cm.

- To terminate teach-in, deactivate the “Teach-in Monitoring Range” button.

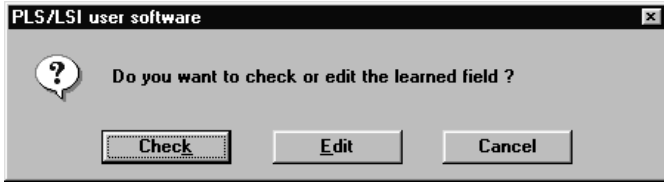

This dialog box appears. You now have three options:

- You can use the taught-in protective field.
- You can edit it as a segmented field.
- Or you can check it and then activate it in the PLS.

Reject protective field:

- Click on “Cancel”. The taught-in protective field is rejected and the old field retained.

Edit protective field:

- Click on “Edit”. You can then edit the taught-in protective field like a segmented field and then transmit it to the PLS.

Check protective field:

- Click on “Check”:

The taught-in protective field is shown on-screen. The space contour of the sensor is displayed for comparison purposes.

- Infringe the contour of the protective field intentionally at all points and on all measuring rays (in a range up to 70 cm into the protective field).

The status bar at the bottom of the screen indicates to you whether you have checked all points.

- Deactivate the **Monitoring Range – Check** menu function, or deactivate the “Check Monitoring Range” button on the toolbar.
- Click on “Yes” to transfer the monitoring range into the PLS and confirm with “OK”.

The taught-in protective field is now active in the PLS.

Note:

You can also edit the taught-in protective field subsequently and then transmit it as a segmented protective field to the PLS.

9.6 Monitor protective field

You have the option of monitoring the contour lines and the defined protective field in operation, by means of a connected PC.

- From the menu choose **Monitoring Range – Monitor**.
- Or click on the “Monitor Monitoring Range” button on the toolbar.

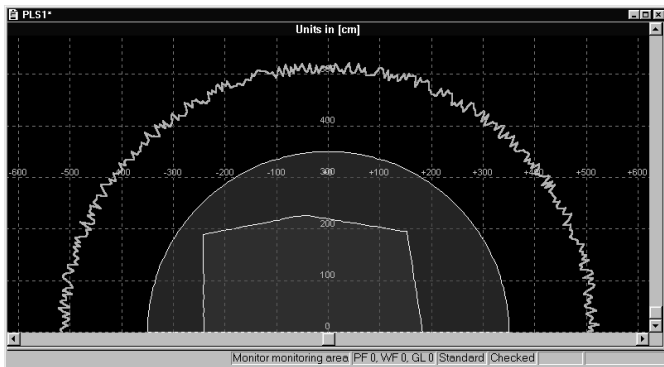

You see the protective field and the space contour on-screen.

Save space contour

You can receive and save the defined space contour of a sensor. In this way, when error shutdowns occur you can check at which point the protective field was infringed.

- From the menu choose **PLS – Tools – Save Space Contour**.

9.7 Check settings

You can call up an overview at any time showing all the configuration and monitoring range settings. You can also print out the overview.

Note:

This page view does not show you the actual configuration active in the PLS, but only the settings you are currently editing on the PC. How to receive the active configuration from the PLS and print it is described in the next section.

- From the menu choose **File – View**.

A page appears listing all the configuration settings in text and diagrams. You can check over your settings any time here.

Change size of screen view:

You can zoom the screen view in or out in two stages.

- Click on the “Zoom In” or “Zoom Out” button. The view is zoomed or unzoomed one stage.
- Or click on the place you want to zoom into. The view is zoomed one stage at the selected point.

Print page:

- Click on the “Print” button.

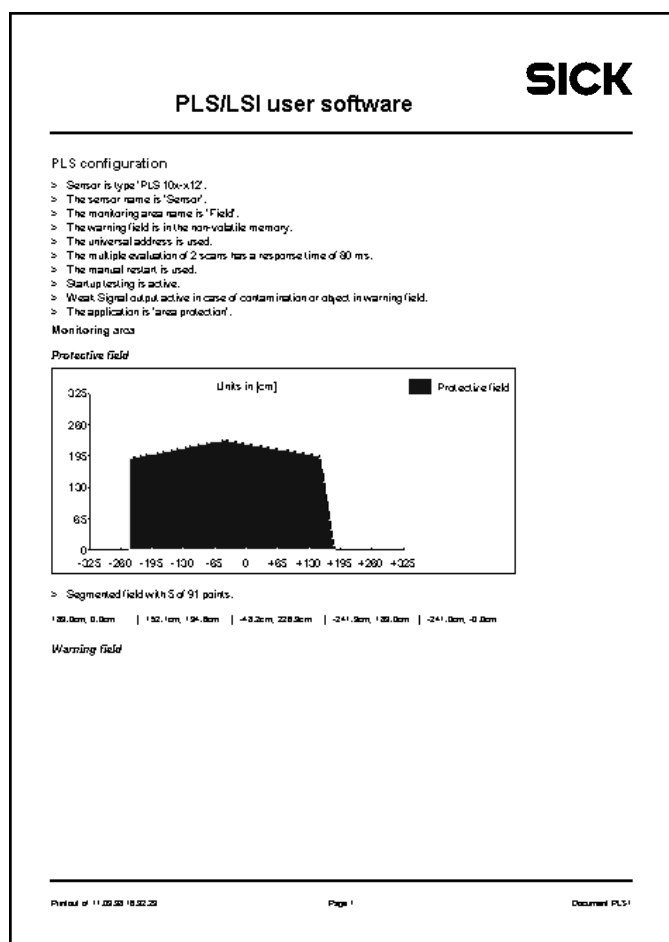

9.8 Receive and store configuration

Receive configuration from PLS

You can receive and print the configuration data stored in the PLS.

- From the menu choose **PLS – Configuration – Configuration Log**.

The PC receives the current configuration from the PLS. The screen displays an overview of all the configuration settings stored in the PLS.

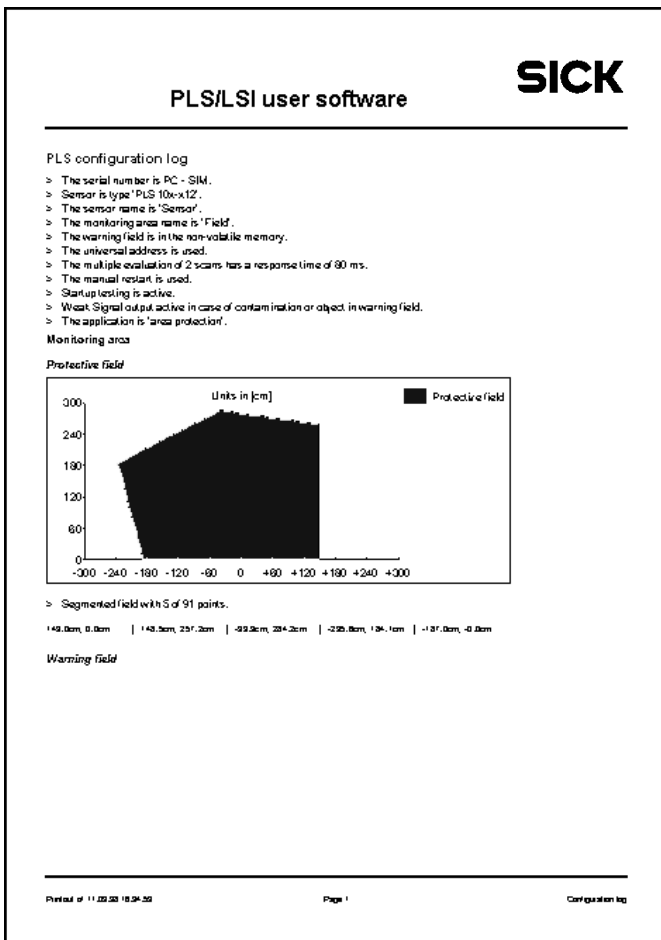

Change size of screen view:

You can zoom the screen view in or out in two stages.

- Click on the “Zoom In” or “Zoom Out” button. The view is zoomed or unzoomed one stage.
- Or click on the place you want to zoom into. The view is zoomed one stage at the selected point.

Print log:

- Click on the “Print” button.

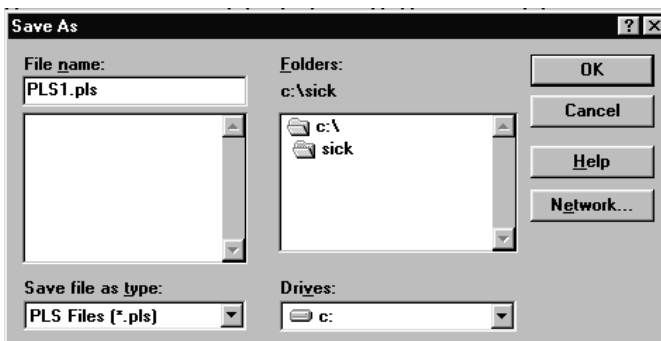

Store configuration

You can save all configuration and monitoring range settings to the hard disk or to a floppy.

- From the menu choose **File - Save As** to save the settings.

You can call up the stored file again later to change the settings or transmit them to the PLS.

9.9 Change password

To be able to send configuration data and monitoring areas to the PLS, you must log on as an “Authorized Client”. This requires a password (default: “SICK_PLS”).

To protect your PLS system against manipulation, you should change the default password and keep it in a safe location accessible only to authorized persons.

To change the password:

- From the menu choose **PLS - User Category**, or click on the “Logon/Logoff User Category” button on the toolbar.
- Log on as an “Authorized Client”, using the old password (e.g. “SICK_PLS”).
- Choose **PLS - Password - Change for Authorized Client**.

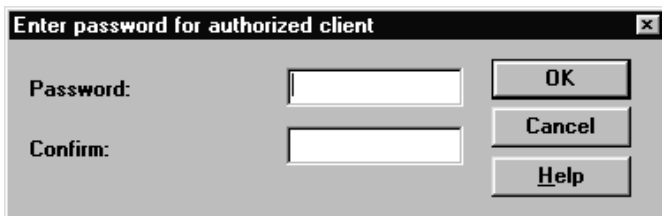

This dialog box appears.

- Type in the new password twice – once in each box. On-screen it is shown only as a series of asterisks.
- Confirm with “OK”.

The new password is stored in the PLS.

- Log off.
- Make a note of the new password at a location accessible only to authorized persons.

Note:

The new password takes immediate effect. But please be sure to always log off before leaving your workstation! Only if you do so can the password protect your PLS system against manipulation.

9.10 Change screen view

You can enlarge, reduce or move the fields on-screen to make them look as you want.
You can also choose between a circular and a rectangular background.

Enlarge or reduce view

- Click on the “Zoom In (+)” button on the toolbar.

The zoomed segment is zoomed one stage further with every click of the mouse.



- Or click on the “Zoom Out (-)” button on the toolbar.

The zoomed segment is unzoomed one stage further with every click of the mouse.



Move view

- Click on the “Move” button on the toolbar. The cursor changes shape into a four-pointed arrow.
- Hold the mouse button pressed down and move the screen segment to where you want it.

... or:

- Move the view using the scroll bars at the right and bottom of the screen.



Center view

- Click on the “Center” button on the toolbar. The zero point is now back in the center of the screen.

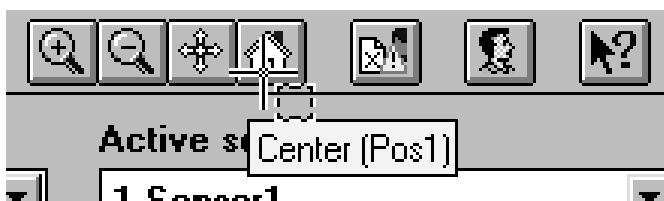

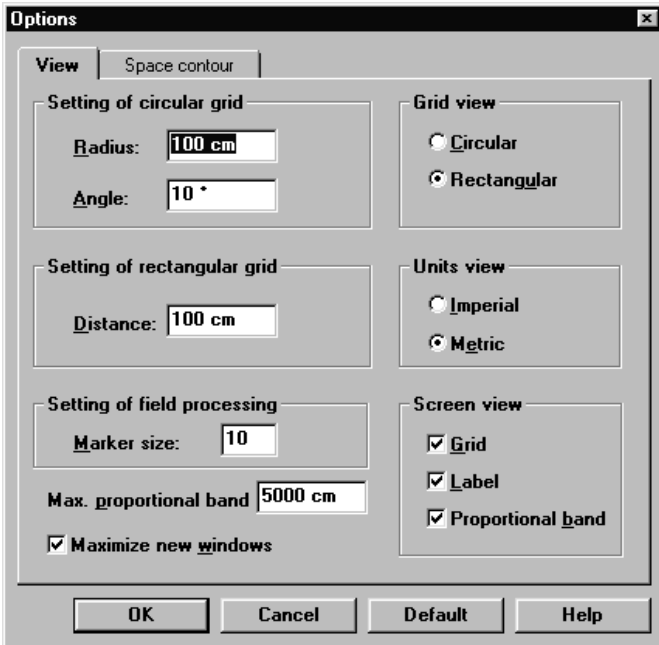

Change grid pattern

You can switch between rectangular and circular grid patterns.

- From the menu choose **View – Options**
- In the dialog box select the “View” tab.
- Check the checkbox for rectangular or circular grid pattern.
- Set your desired grid width.
- Set your desired maximum visible area.
- Check the checkbox for metric or imperial units.
- Check the checkboxes to display the grid pattern, labels and visible area on-screen.

Restore defaults:

- Click on the “Default” button. All values are reset to their defaults.

Confirm setting:

- Click on “OK”.

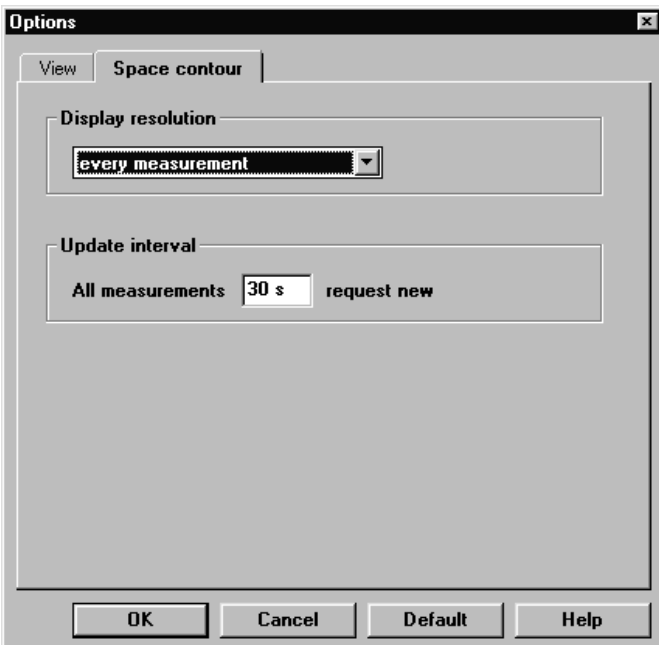

Set displayed data

You can set how many measured values of the space contour are to be displayed in monitoring and editing of the fields.

Note:

The more measured values you display, the more accurate the display will be, but the slower it will be too.

- From the menu choose **View – Options**.
- Select the “Data” tab.
- Select how many measured values of the space contour you want to evaluate.
- Enter the time intervals at which new values are to be requested during editing.

9.11 Interrogate fault memory (system diagnosis)

If your PLS is not functioning as you would like it, you can interrogate the fault memory of the PLS in a number of different steps to localize possible faults.

The fault table in section 10.3 will tell you what to do then to rectify the fault.

Initial fault diagnosis

As the first step you can carry out a simple diagnosis to localize faults.

- From the menu choose **PLS – Diagnosis**.

This dialog box appears.

- Click on “Execute”.

The diagnosis is carried out and the window displays information on the current status of your PLS system. The fault codes are given in the bottom section of the list display. To find out what the fault codes mean, and whether you can rectify the fault yourself, refer to the fault table in section 10.3.

If necessary you can also carry out a second diagnosis to get more detailed information. The more detailed diagnosis is described in the following.

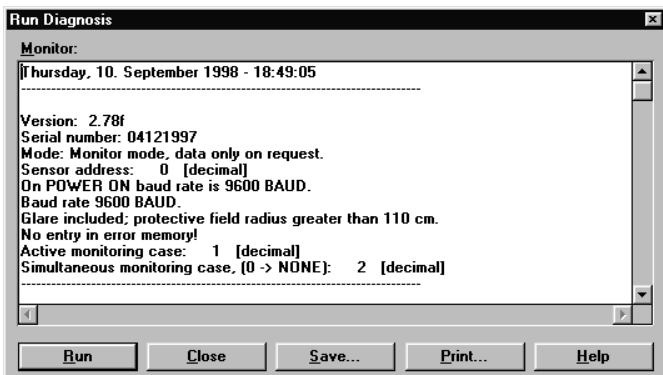

Interrogate PLS fault memory

- From the menu choose **PLS - SICK Diagnosis**.

This dialog box appears.

- Make sure zero is entered as the device address and “PLS” as the device type, and confirm with “OK”.

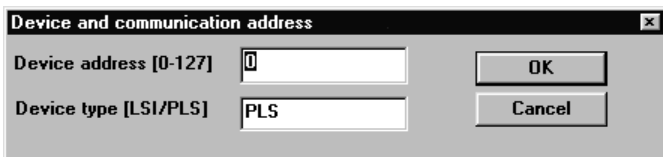

The “Execute Diagnosis” dialog box appears. In it you will find various telegrams with which you can execute additional commands and functions.

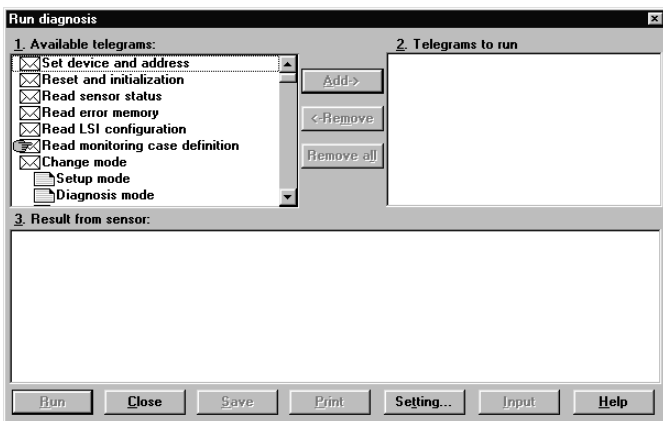

Read error memory

- In the list of available telegrams select the “Read fault memory” telegram and click on “Add”.

Read sensor status

- Select the “Read sensor status” telegram and click on “Add”.

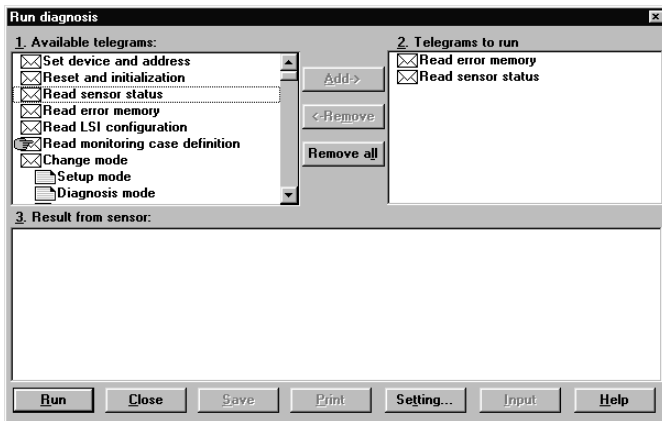

The two telegrams are now entered one under the other in the list of telegrams for diagnosis.

- Click on “Execute”.

The fault memory of the PLS and the sensor status are read, and the result log is displayed in the box at the bottom of the screen. You can find out what the listed fault codes mean from the fault table in section 10.3.

You can add supplementary information to the result log, print it, or save it as a file.

Enter supplementary information:

- Click on “Input” and enter the text you want. Your text is then appended to the result log.

Print result log:

- Click on “Print”.

Save result log as file:

- Click on “Save” and enter a file name and destination directory/folder.

Note:

When you have rectified the fault reset the PLS: choose **PLS – Initialize**.

Or execute the “Reset and initialization” telegram in the SICK diagnosis.

The PLS system is then restarted.

10 Care and Maintenance

The PLS is maintenance-free.

Note:

Do not open the sensor up! It does not contain any parts you can repair. In case of damage to the PLS contact SICK Service.

Cleaning the front screen

To enable the sensor to function fault-free, you should clean the front screen as soon as slow rhythmic flashing (once per second) of the yellow LED accompanied by a steadily lit green LED signals slight contamination.

The PLS will still keep working in this state. Only as the degree of dirt contamination increases will the yellow LED come on steadily, the PLS switches off and the red LED lights up (see "LEDs on the PLS").

Clean the front screen only with a soft cloth and plastic cleaner. Never use rough rags or aggressive cleaning agents such as acetone etc.! Otherwise the front screen may be damaged.

If the front screen is scratched or damaged and needs to be replaced, you can order a replacement from SICK (see Appendix under "Accessories") and replace it yourself.

Replacing the front screen

Notes:

The front screen must only be replaced by knowledgeable personnel, in a clean environment.

The front screen of the PLS is an optical component which must not be contaminated with dirt or scratched during replacement.

Before removing the front screen disconnect the power connector to cut power to the unit!

- Loosen the eight hexagon socket screws on the front screen and remove the old screen.
- Mount the new screen (as far as possible holding it only with a clean, soft cloth).
- First screw the four screws in the middle of the screen back in, then the four at the ends (slots). Tighten the screws to around 0.7 Nm.
- Reconnect the power to the PLS and calibrate the contamination measurement by means of the PLS user software: From the menu choose "SICK Diagnosis", select the "Setup mode" and "Calibration of contamination measurement" telegrams and execute them.
(You will find more details on this in section 9 under "Interrogate fault memory – System diagnosis").
The new front screen must not be contaminated with dirt when the calibration is performed.

10.1 SICK Service / Hotline

If a fault occurs (e.g. the yellow LED is flashing rapidly, at around 4 times per second), be sure that your first step is always to carry out the fault diagnosis in the PLS user software. You will find more details on this in section 9 under "Interrogate fault memory - System diagnosis". This SICK diagnosis function will provide you with detailed information about the fault which has occurred. You can find out what the fault code means from the fault table in section 10.3 and ascertain whether you can rectify the fault yourself.

If you are unable to rectify the fault yourself, please contact your nearest supplier.

Print out the fault report produced by the SICK Diagnosis function and have it to hand when you contact SICK Service.

If you need to send in the PLS, please also enclose the fault report together with the completed Service questionnaire. You will find a master copy of the Service questionnaire in section 10.4.

If you are having difficulties or are unsure about how to use your PLS, please contact our hotline. You can reach it under the number given above.

SICK also offers an Installation and Commissioning service package. Our Service department will be able to help you if you need further assistance.

10.2 LEDs on the PLS

The PLS has three light-emitting diodes (LEDs) which deliver important information.

In this regard also refer to the description of the user software as from section 9, which gives detailed information on programming of the fields and outputs.

Red and green LEDs:

The red and green LEDs indicate the status of the protective field and the outputs.

For PLS type 101-312:

Yellow LED:

The yellow LED indicates whether the warning field has been infringed or the front screen of the sensor is contaminated with dirt. You can set which option you want in the user software. The description of the user software, section 9.3, gives detailed information on setting the "Weak Signal" output.

Also, in conjunction with the red LED this yellow LED indicates whether the sensor is awaiting release (restart).

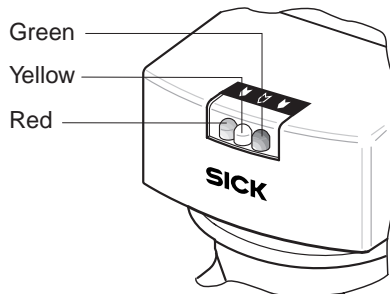

PLS LEDs:

Status	Green	Yellow	Red
Protective field free	⊙		
Object in protective field			⊙
Object in warning field		⊙	
Waiting for restart		⊙ 1 Hz	⊙
Contamination warning *		⊙ 1 Hz	
Contamination *		⊙	⊙
Self-test negative **		⊙ 4 Hz	⊙

⊙ = LED lit
 ⊙ 1 Hz = LED flashing slowly
 ⊙ 4 Hz = LED flashing rapidly

* Clean front screen with plastic cleaner and a soft cloth.

** Carry out system diagnosis (see section 9).

For PLS types 101-112 and 101-212:

Yellow LED:

The yellow LED indicates whether the warning field has been infringed or the front screen of the sensor contaminated with dirt. You can set which option you want in the user software. The description of the user software, section 9.3, gives detailed information on setting the "Weak Signal" output.

PLS LEDs:

Status	Green	Yellow	Red
Protective field free	⊙		
Object in protective field			⊙
Object in warning field		⊙	
Contamination warning *		⊙ 1 Hz	
Contamination *		⊙	⊙
Self-test negative **		⊙ 4 Hz	⊙

⊙ = LED lit
 ⊙ 1 Hz = LED flashing slowly
 ⊙ 4 Hz = LED flashing rapidly

* Clean front screen with plastic cleaner and a soft cloth.

** Carry out system diagnosis (see section 9).

10.3 PLS fault table

For safety reasons your PLS continuously performs self-test routines to guarantee fault-free functioning of the unit in case of danger. If one of these tests fails when the system is starting up or during operation, the PLS automatically shuts down the dangerous machine or plant as a safety precaution.

This table enables you to find out what the SICK diagnosis fault codes mean, and whether you can rectify the fault yourself. How to execute the SICK diagnosis is described in section 9.1.1.

Note:

If you get a fault code which you cannot find in this table, please contact SICK Service.

Fault code:	Cause / What you can do about it:
0	System working properly
2	Memory test failed: Cut the power to the PLS for at least three seconds. If the problem persists, contact the SICK Hotline.
17-20	Dirt contamination of the front screen: Clean the front screen or replace it (note that you will need to carry out the front screen calibration in the SICK diagnosis after replacing a screen).
23	Mutual interference between several PLS units: Eliminate the interference by changing the PLS mounting configuration. Follow the mounting instructions in section 7. Motor speed incorrect: Operating at low temperatures. Observe the specifications of the unit (see Technical data).
27	External circuitry of OSSD 1 faulty: Check the wiring of the external circuitry. Test for short-circuit in the shutdown path to 0 Volts, to 24 Volts and to the second shutdown path. Make sure the resistive and capacitive load on the shutdown path complies with the unit specifications. Also test the connectors and the crimping of the cabling. Undervoltage in power supply to unit: Make sure the power supply to the unit complies with the specifications in the technical data. Measure the voltage directly on the PLS, to take account of any voltage drop resulting from long supply lines.
28	External circuitry of OSSD 2 faulty: See error code 27 Undervoltage in power supply to unit: See error code 27
29	Motor speed incorrect: Operating at low temperatures. Observe the specifications of the unit (see Technical data).
41	Shutdown paths not interacting correctly: See error codes 27 and 28
42	Sensor receiving no data over 90° of its measuring range: To ensure fault-free functioning of the sensor, make sure it is always receiving measured data within a range of 90°, freely adjustable within the scanning area. In area protection this is normally always the case, so the PLS signals the fault after three seconds. In vehicle protection a condition of this kind may occur briefly while the vehicle is moving across the hall, so the unit only signals this fault after two hours.

10.4 Service questionnaire

On the following pages you will find our Service questionnaire. The questionnaire is designed to record all relevant data relating to any PLS laser scanner sent in to us.

Based on the information you give, we are able to take all necessary measures straight away to ensure your scanner is returned to you as soon as possible.

Please return the completed questionnaire with the scanner.

By completing the questionnaire below you will help us in carrying out fault diagnosis. As soon as we have the following details, we will get back to you as quickly as possible. This makes efficient handling of claims possible.

Company _____
Contact _____ SICK contact _____
Address _____
Phone _____ Fax: _____

Hardware as per rating plate: PLS model: PLS ____ - ____
Order number: 1 0 ____ - ____
Device number: 9 ____ - ____

Software: PLS user software version: 0_ . __
– Choose “About User Software” from the “Help” menu.

Sensor status: Please enclose printout:
– Log on to the user software as an “Authorized Client”.
– Choose “Sick Diagnosis” from the “Sensor” menu.
– Select, add, execute and save the telegrams “Read sensor status” and “Read fault memory”.

Application: Area protection Mobile application

Problem: _____

If the yellow LED is flashing rapidly (4 times per second):

– Is the voltage to the PLS power connector in the permissible range?
No Yes Please enter the mean voltage: ___V

If the red LED is flashing (approx. 2 times per second):

– Does the 24 V power pack of the PLS have a load capacity of at least 1.5 A ? No Yes

If the red LED is active:

– Where is the protective field being infringed ? Interior Edges

– Please describe the application and any critical ambient conditions:

_____ Sketch of application on back: Yes No

11 Appendix

11.1 Characteristics

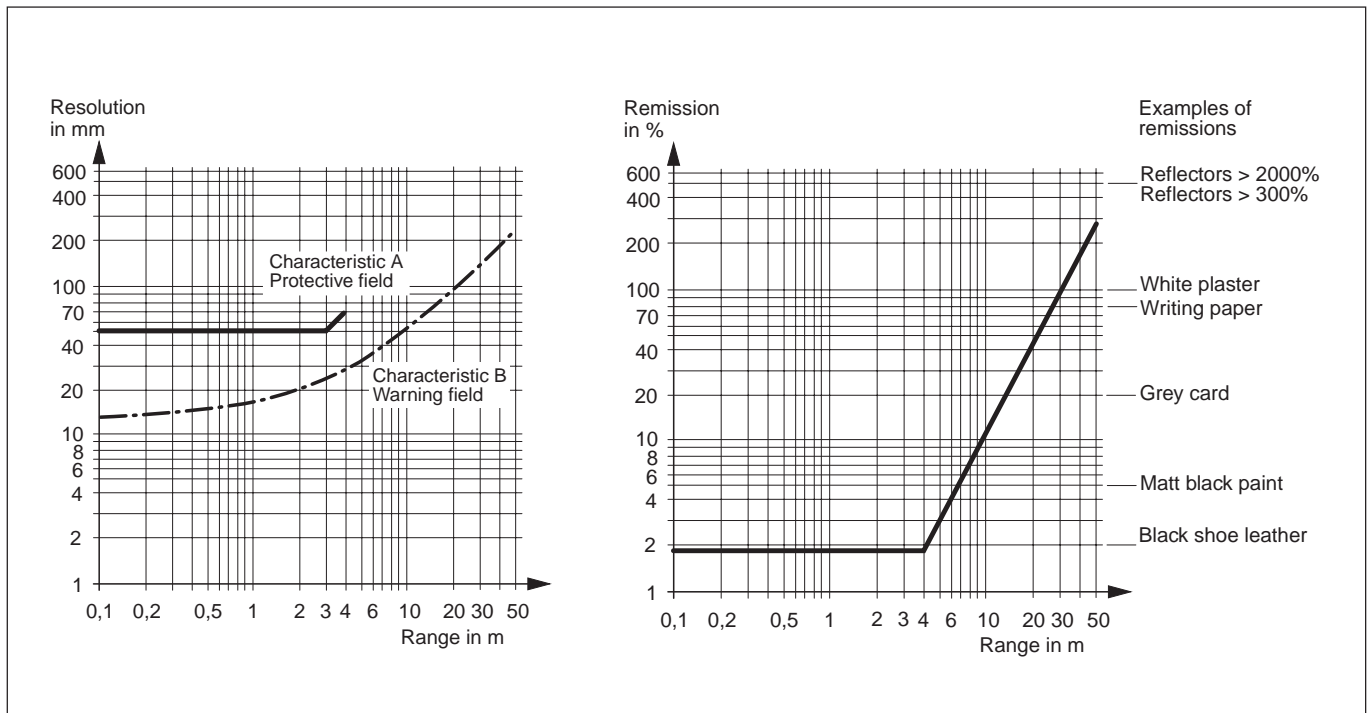

Characteristics: Correlation between reflectance of object, range and resolvable object diameter.
 The given remission relates to a worst-case contaminated front screen.

11.2 Accessories

Note:

If you want to deploy one or more PLS together with a LSI (Laser Scanner Interface), you will find the necessary accessories listed in the appendix to the technical description of the LSI.

PLS variants

	Order no.
PLS 101-312	1 016 066
PLS 101-112	1 012 571
PLS 101-212	1 012 572
PLS 201-113	1 012 569
PLS 201-213	1 012 570
PLS 201-313	1 016 189

Mounting kits

	Order no.
Mounting kit 1, incl screws for	2 015 623
Mounting kit 2, incl screws for mounting kit 1	2 015 624
Mounting kit 3, incl screws for mounting kits 1 and 2	2 015 625

Connection set

Instead of connection set 1, which is supplied as standard, you can order one of the connection sets 2 to 7, which include a cable fitted to the power connector (cable outlet upward). Various cable lengths are available:

	Order no.
Connection set 1, power and interface connectors without cable	2 016 184
Connection set 2, with 3 m cable	2 016 185
Connection set 3, with 5 m cable	2 016 186
Connection set 4, with 10 m cable	2 016 187
Connection set 5, with 15 m cable	2 016 188
Connection set 6, with 20 m cable	2 016 189
Connection set 7, with 30 m cable	2 016 190

Interface cables

For RS 232 (all PLS types) and for RS 422 (PLS type 101-212):

	Order no.
3 m interface cable	2 016 401
5 m interface cable	2 016 402
10 m interface cable	2 016 403

For RS 422 (PLS types 101-312 only):

	Order no.
3 m interface cable	2 019 130
5 m interface cable	2 019 131
10 m interface cable	2 019 132

Documentation and user software

Technical description, German, SW 3.xx / 4.xx with user software, German	2 019 127
Technical description, English, SW 3.xx / 4.xx with user software, English	2 019 128
Technical description, French, SW 3.xx / 4.xx with user software, French	2 019 129

Other SICK accessories

	Order no.
Power pack 24 V, 2,5 A	6 010 361
Power pack 24 V, 4 A	6 010 362
Interface module LCU-X	1 013 410
Replacement front screen (with seal and screws)	2 016 408

And also ...

You can obtain the following accessories as required from computer equipment suppliers:

- Interface adapter 9-pin (plug) to 25-pin (socket):
If you want to connect a PC which only has a 25-pin serial port connector.
- Crimping tool:
If you want to self-assemble your power and interface connectors.
Available from: Please telephone your nearest stockist.

11.3 Technical data

Here you will find the key technical data of the PLS.

Note:

If you want to deploy one or more PLS together with a LSI (Laser Scanner Interface), please also take note of the technical data of the LSI (see technical description of LSI).

Protective field

Range	4 m radius
Response time, typ.	Adjustable, min. 80 ms
Min. remission	1.8 % diffuse
Max. remission	Unlimited (safe operation also on reflectors)
Resolution	Better than 70 mm (see diagram)
Output	2 x protective semiconductor outputs PNP, 24 V / 250 mA
	Load must exhibit low-pass behavior (f_g : approx. 500 Hz)
	Residual voltage (at 250 mA load) max. 3.4 V
	Max. switching frequency 12.5 Hz
Category:	Single-fault safe, Comparable cat. 3 to EN 954-1 PLS type 101-312: Type 3 to IEC/EN 61496-1 PLS type 101-112 and 101-213: Type 3 to EN 50100-1

Warning field

Range	Approx. 15 m radius
Remission/resolution	(See characteristic B in diagram)
Typ. for 15 m	20%, 80 mm object diameter
Output	Semiconductor output, PNP, 24 V / 100 mA

Measuring range

Range	Max. 50 m
Remission	(See diagram)
Resolution	
Distance measurement	± 50 mm
Angular resolution	0.5°

Power and signal lines

PLS 101-312:	
VCC_EXT	+ 24 V +20%/-30% (+ 24 V = U_{nom})
PLS 101-112, 101-212:	
VCC_EXT	+ 24 V +/-15% (+ 24 V = U_{nom})
Residual ripple	500 mV (V_{PMS})
OSSD	Transistor output PNP
I_{max}	250 mA
Load capacitance	100 nF
Short-circuit-protected	By monitoring of outputs
Load	Apply to GND_EXT
Residual voltage	(at 250 mA load) max. 3.4 V
WEAK-SIGNAL	Transistor output PNP
	Contamination = Low
I_{max}	100 mA, short-circuit-proof
Load	Apply to GND_EXT
RESTART	Apply button to VCC_EXT
Line length L_{max}	30 m (with cross-section 0.5 mm ²)

Data lines

RS 232 C	Transmission range max. 15 m
RS 422 A	Transmission range max. 100 m

General data

Scan area	Max. 180°
Angular resolution	0.5°
Supply voltage	24 V DC via isolating transformer to EN 60 742 (also charger for conveyor vehicles)
Power consumption	≤ 17 W, plus load at outputs (max. 24 V / 2 x 250 + 100 mA)
Laser protection class	1
Enclosure rating	IP 65, to EN 60529
Protection class	Totally insulated, protection class 2
Ambient operating temperature	0 ... + 50°C
Storage temperature	- 25 ... + 70°C
Dimensions (WxHxD)	155 mm x 185 mm x 156 mm
Measuring error	Typ. ± 50 mm
Worst case:	Max. 94 mm at 2 m distance Max. 131 mm at 4 m distance
Interface	RS 232: PLS type 101-112 RS 422: PLS type 101-212 Universal: PLS type 101-312
Transfer rate	RS 232: 9600 Baud - 56 kBaud RS 422: 9600 Baud - 500 kBaud
Electrical connection	Plug-in connection box for 0.5 mm ² Crimp connection, PG 9
Sender	Infrared laser diode
Receiver opening angle	$\pm 1^\circ$
Housing material	Die-cast aluminum
Front screen	Polycarbonate, with scratch-proof coating
EInputs	Command unit for "with restart inhibit" mode Make contact to VCC_EXT, dynamically monitored
Humidity	DIN 40040, table 10, code letter E (moderately dry)
Vibration	IEC 68, part 2-6, table c2
Frequency range	10 ... 150 Hz
Amplitude	0.35 mm or 5 g
Single shock	IEC 68, part 2-27, table 2 11 g / 11 ms
Continuous shock (1000)	IEC 68, part 2-29, 10 g / 16 ms
Interference immunity (EMC)	
PLS 101-312 to IEC 61000-4	
PLS 101-112, 101-212 to IEC 801 part 2 - part 6	
Additional emission tests to:	EN 55 011 EN 55 022 EN 55 014 EN 50081 - 1/2

11.4 Standards and regulations

The following lists the key standards and regulations applicable to the use of optoelectronic safety devices in Europe and in the Federal Republic of Germany. Depending on field of application, additional regulations may be of importance for you. You can get information on other device-specific standards from local regulatory authorities, or from professional bodies. If the machine or vehicle is operated in a country not belonging to the European Union, we recommend contacting the plant operators and the local authorities.

Regarding the use and installation of safety devices:

Maschinenrichtlinie 89 / 392 EWG

Machinery directive 89 / 392 EEC

Safety of machines – Basic terms, general design guidelines (EN 292)

Safety of integrated manufacturing systems (DIN EN 1921)

Safety of machines – Electrical equipment on machines – Part 1: General requirements (EN 60204)

Safety of machines – Safety distances to prevent reaching hazardous areas with upper limbs (EN 294)

Safety requirements for robots (EN 775)

Safety rules for non-contact safety devices on power-driven machinery (ZH 1/597)

Safety of machines – Arrangement of safety devices with regard to approach speed of body parts (prEN 999)

Safety of machines - Risk assessment (prEN 1050)

Regarding construction and equipping of safety devices:

Safety of machines – Non-contact safety devices – Part 1: General requirements (prEN 50100-1 and -2 / DIN VDE 0113, part 201)

Safety of machines – Electrical equipment on machines – Part 1: General requirements (EN 60204)

Safety of machines – Safety-related components of controls – Part 1: General design guidelines (prEN 954)

On these subjects please also order our brochure “Safe machines with optoelectronic safety devices”.

EC Declaration of Conformity



In Compliance with the EC Directive on Electromagnetic Compatibility 89/336/EWG

We hereby declare that the devices (see page 2)

of the product family PLS201-313

comply with the basic requirements of the EC Directive specified under Point 1. If an item of equipment listed overleaf is modified without our approval then this declaration loses its validity for this equipment.

We employ a quality system certified by the DQS (German Quality Assurance Society), No. 19 462-01, as per ISO 9001 and have therefore observed the regulations in accordance with module H as well as the following EC directives and EN standards during development and production:

- | | | | |
|---|---|-------------------------------|-----------|
| 1. EC directives | EC EMC directive 89/336/EEC as per 92/31/EEC, 93/68/EEC, 93/465/EEC | | |
| 2. Harmonized standards and preliminary standards used | EN50081-2 | Emitted interference, indust. | Ed. 94-03 |
| | EN50082-2 | Immunity, indust. | Ed. 96-02 |

Conformance of a type sample belonging to the above-mentioned product family with the regulations from the listed EC directives has been certified by:

Test authority Montena emc sa
CH-1728 Rossens

Test no. 9711022-01 dated 1997-11-27

Waldkirch/Br., 1998-04-20

ppa. Windau
(Head of Sales & Marketing
Division Safety Systems)

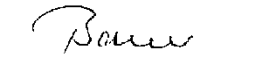
ppa. Dr. Bauer
(Head of Development)

The declaration certifies conformance with the listed directives, but does not guarantee product characteristics. The safety instructions contained in the product documentation must be observed.

Mat. No.: 9 051 806
Page 3, engl.

Update no.: see page 2

SICK AG
Sebastian-Kneipp-Str. 1
D-79183 Waldkirch

Telefon (0 76 81) 202-0
Telex 772314
Telefax (0 76 81) 38 63

Aufsichtsratsvorsitzender:
Dr. Horst Skoludek
Vorstand:
Volker Reiche (Vors.)
Anne-Kathrin Deutrich
Dieter Fischer

Sitz: Waldkirch i.Br.
Handelsregister
Emmendingen HRB 355 W

EC Declaration of Conformity



In Compliance with the EC Directive on Electromagnetic Compatibility 89/336/EWG

We hereby declare that the devices (see page 2)

of the product family PLS20.-1.. , PLS20.-2..

comply with the basic requirements of the EC Directive specified under Point 1. If an item of equipment listed overleaf is modified without our approval then this declaration loses its validity for this equipment.

We employ a quality system certified by the DQS (German Quality Assurance Society), No. 19 462-01, as per ISO 9001 and have therefore observed the regulations in accordance with module H as well as the following EC directives and EN standards during development and production:

- | | | | |
|---|---|-------------------------------|-----------|
| 1. EC directives | EC EMC directive 89/336/EEC as per 92/31/EEC, 93/68/EEC, 93/465/EEC | | |
| 2. Harmonized standards and preliminary standards used | EN50081-2 | Emitted interference, indust. | Ed. 94-03 |
| | EN50082-2 | Immunity, indust. | Ed. 96-02 |
| | | | |

Conformance of a type sample belonging to the above-mentioned product family with the regulations from the listed EC directives has been certified by:

Test authority Laboratoire EMC Fribourg SA
Zone Industrielle
CH-1728 Rossens

Test no. 10650 dated 1995-04-05

Waldkirch/Br., 1996-07-27

i. V. Windau
(Head of Sales & Marketing
Division Safety Systems)

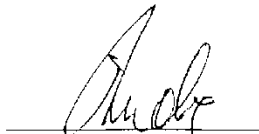
i. V. Zinober
(Head of Production
Division Safety Systems)

The declaration certifies conformance with the listed directives, but does not guarantee product characteristics. The safety instructions contained in the product documentation must be observed.

Mat. No.: 9 044 441
Page 3, engl.

Update no.: see page 2

2 Notices / Regulation Use

The PLS types 201-113, 201-213 and 201-313 are not certified as safety devices. Their use for personal protection is therefore not permitted.

The recommendations regarding mounting apply.

3 How the PLS Works

This section applies.

4 Fields of Application – What the PLS Can Do

Not relevant.

5 Location Planning

5.1 Not relevant.

5.2 Only relevant for collision protection if danger to persons resulting from a collision can be excluded.

6 Supply Package

This section applies.

7 Mounting the PLS

This section applies.

8 Connecting Up the PLS

Not relevant.

9 Programming the PLS with the User Software

This section applies.

10 Care and Maintenance

This section applies.

11 Appendix

Technical data: The protective field radius for these PLS types is programmable up to 50 meters. Since the resolution dependent on the distance from the scanner is more than 70 mm, these PLS types must not be used for personal protection. Therefore a test to EN 50100 or IEC 61496 is also irrelevant.

The resolution of these scanners is shown in the adjacent diagram.

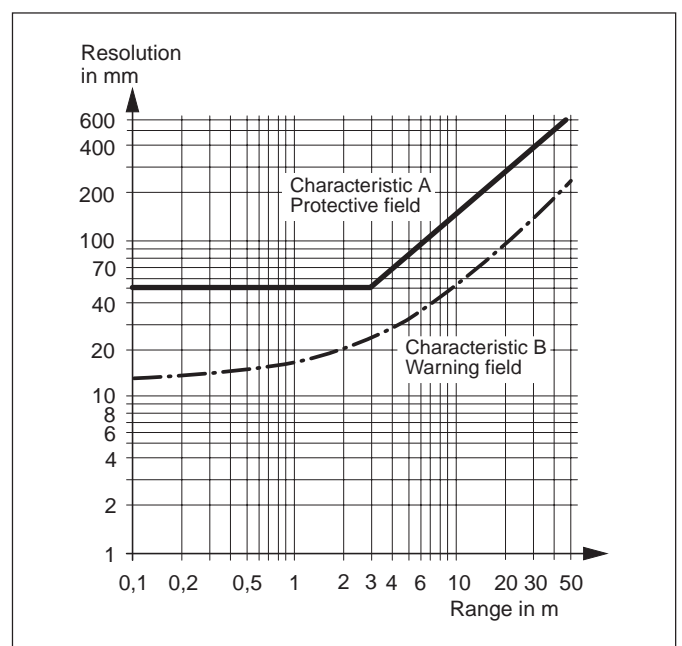

12 Glossar

DTS

Driverless Transport System (industrial conveyors).

Measurement zone

The field of vision of the PLS is its measurement zone. It is heavily dependent on the remission of the object struck, but without special measures also extends to around 15 metres. When using heavily reflective materials the maximum range of 50 metres is also achievable.

With the PLS the distance to objects can also be measured in order to display them on the PC (by way of the computer interface) or to carry out any other evaluations on a computer.

Offset value

Tolerance supplement due to measuring error for full availability.

Protective field

In the “close-up zone” (radius 4 meters) the PLS offers a sensor field with fail-safe accident prevention functions in accordance with category 4 of DIN 19250 – for area protection but also as a (non-tactile) bumper replacement.

Teach-in process

Method by which a contour is entered by running along a target board.

Warning field

The warning field is a sensor field with a radius up to 15 meters. It can be used to monitor larger areas and to trip simple switching functions (e.g. warning functions) or to switch a driverless transport system to slow running.

Startup testing

When the power has been connected the sensor releases the plant only when the protective field has been purposely infringed one time.

Restart inhibit

The sensor releases the plant only after acknowledgment by way of an externally connected command unit.

Fault memory

A code describing the occurring fault is written to the fault memory. The code can be read-out by the SICK diagnosis system to enable fault analysis.

Sensor status

The sensor status characterizes the overall state of the system in detail. The data it contains are required to analyze the system.

Verification of the protective field

To ensure the registered contour really matches the area being protected, especially when teaching-in a protective field, it is necessary to “show” the sensor the desired field a second time as confirmation. This is done in the so-called verification process, by slowly running a target board over the contour along the inside of the protective field (toward the sensor), but no more than 70 cm from the edge of the protective field. The process can be tracked on-screen by following the change in beam color from red to green.

Remission

The remission describes the diffuse reflectance of surfaces.

OSSD

The OSSD output is the switching output of the PLS. It is semiconductor-based, and its fault-free functioning is tested periodically. The PLS has two parallel-working OSSD outputs, which for safety reasons must be evaluated on two channels.

Segmented field

Protective fields are handled in segmented form; that is to say, a protective field consists of triangular areas touching each other at the edges of the field. You can freely select the number of segments on which a field is based between 90 and 360. You should note, however, that the earlier software version 3.0X was only capable of processing 180 segments. If you program a field with a new 3.2X user software version and view it subsequently using the old software, the display may be distorted. It is therefore advisable to replace all old 3.0X software versions with the new 3.2X version.