

# Inductive proximity sensors

## IQ 12 series, sensing range 2 / 4 mm

### DC 3-wire, plastic housing

Dimensions in mm



#### Features



- ▶ Can be installed flush or non-flush in metal
- ▶ PNP or NPN output
- ▶ High switching frequency
- ▶ Short-circuit protection (pulsed)
- ▶ Plastic housing
- ▶ Cable or connector
- ▶ Enclosure rating IP 67
- ▶ LED status indicator (with 4 x 90° connectors)
- ▶ Installation notes see page 17

#### Accessories

Round connectors

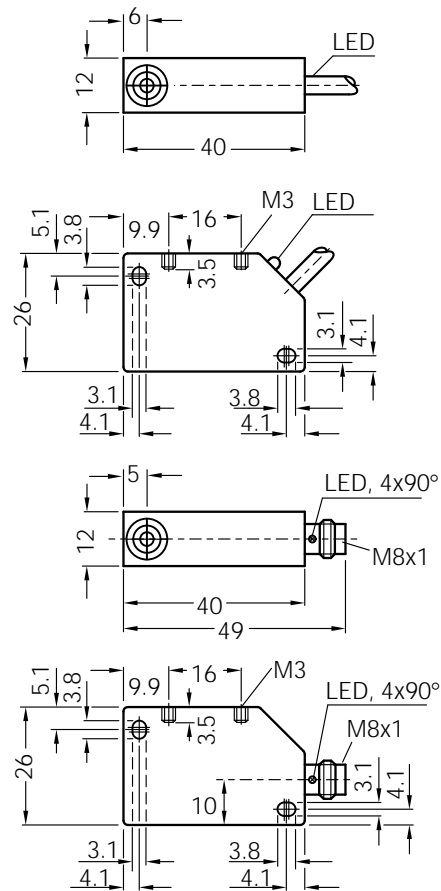

#### Connection diagram

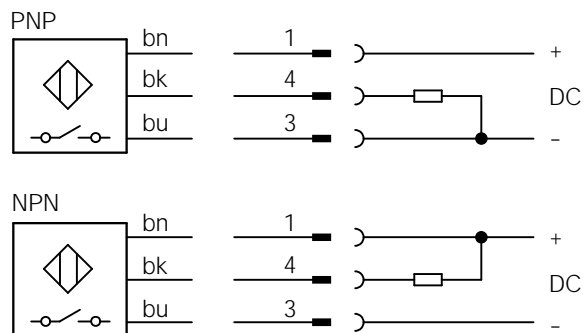



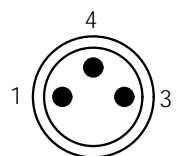













Wire colour	Contact	Assignment
bn brown	1	+ V DC
bk black	4	NO
bu blue	3	- V DC



## Electrical and mechanical data

<b>Operating voltage</b> $U_b$	10 ... 30 V DC	<b>Wire-break protection</b>	yes
<b>Ripple</b> $U_{pp}$	$\leq 10\%$ of $U_b$	<b>Short-circuit protection (pulsed)</b>	yes
<b>Voltage drop</b> $U_d$	$\leq 1.5$ V at $I_a$ max.	<b>Reverse polarity protection</b>	yes
<b>Power consumption</b> (without load)	$\leq 10$ mA	<b>Power-up pulse suppression</b>	yes
<b>Continuous current</b> $I_a$	$\leq 300$ mA	<b>Enclosure rating</b> to DIN 40050	IP 67
<b>Time delay before availability</b> $t_v$	$\leq 2$ ms	<b>Shock and vibration stress</b>	30 g, 11 ms 10 to 55 Hz, 1 mm
<b>Hysteresis</b> H	1% - 10% of $s_r$	<b>Ambient temperature</b> $T_a$	- 25 ... + 75 °C
<b>Repeatability</b> R ( $U_b$ and $T_a$ constant)	$\leq 1\%$ of $s_r$	<b>Housing material</b>	Plastic
<b>Temperature drift</b>	$\pm 10\%$ of $s_r$	<b>Connection cable</b>	PUR-PVC, 3 x 0.25 mm <sup>2</sup>
<b>EMC</b>	to EN 60 947-5-2		

## Selection table

Sensing range $s_n$ mm	Installation in metal	Switching output	Output function	Switching frequency f in Hz	Connection	Type	Order number
2		PNP		3000	Cable 2 m	IQ12-02BPS-KU0	7900211
2		NPN		3000	Cable 2 m	IQ12-02BNS-KU0	7900212
2		PNP		3000	Connector M8 x 1 mm	IQ12-02BPS-KT0	7900213
2		NPN		3000	Connector M8 x 1 mm	IQ12-02BNS-KT0	7900214
4		PNP		3000	Cable 2 m	IQ12-04NPS-KU0	7900215
4		NPN		3000	Cable 2 m	IQ12-04NNS-KU0	7900216
4		PNP		3000	Connector M8 x 1 mm	IQ12-04NPS-KT0	7900217
4		NPN		3000	Connector M8 x 1 mm	IQ12-04NNS-KT0	7900218